

---

## Chapter 14 Water Management (Drainage)



---

Issued April 2001

## Acknowledgments

This chapter was prepared under the general direction of **Ronald L. Marlow**, national water management engineer, Natural Resources Conservation Service (NRCS), Washington, DC, with assistance from **Patrick H. Willey**, agricultural engineer, NRCS, Portland, Oregon. Extensive drafting was previously done by **Richard D. Wenberg**, retired national drainage engineer, with assistance from **John Rice**, **Walter K. Twitty**, **Gordon Stroup**, **Elwin Ross**, and **Virgil Backlund**, retired water management engineers (drainage). Editorial and layout assistance was provided by **Mary Mattinson**, NRCS, Fort Worth, Texas.

The final revision were prepared by **Walter J. Ochs**, **Richard D. Wenberg**, and **Bishay G. Bishay**, water management engineering consultants. Peer reviews were provided by **James E. Ayars**, agricultural engineer, USDA ARS, Pacific West Area, Fresno, California, and **Norman R. Fausey**, soil scientist - research leader, USDA ARS, Midwest Area, Columbus, Ohio.

Reviewers within NRCS include:

**Gordon Klofstad**, national construction engineer, **William Hughey**, national agricultural engineer, **William Irwin**, national design engineer, **John S. Moore**, national hydrogeologist, and **Donald Woodward**, national hydraulic engineer, Washington, D.C.

**John Andrews**, Denver, Colorado, **Grady Adkins**, Columbia, South Carolina, **Arthur Brate**, Columbus, Ohio, **Dennis Carman**, Little Rock, Arkansas, **Walter Grajko**, Syracuse, New York, **Ronald Gronwald**, Dover Delaware, **Mark Jensen**, Des Moines, Iowa, **Richard Judy**, Morgantown, West Virginia, **Tillman Marshall**, Richmond, Virginia, **Perry Oakes**, Auburn, Alabama, **John Ourada**, Salina, Kansas, **Allen Stahl**, Annapolis, Maryland, **Jesse Wilson**, Gainesville, Florida, all state conservation engineers with their respective staffs.

**Michelle Burke**, Brookings, South Dakota, **Gene Nimmer**, Juneau, Wisconsin, and **Chris Stoner**, Stillwater, Oklahoma, all agricultural engineers.

**Jim Bickford**, irrigation engineer, Nashville, Tennessee, **William Boyd**, environmental engineer, Little Rock, Arkansas, **Harold Blume**, water management engineer, Phoenix, Arizona, **Sonia Jacobsen**, hydraulic engineer, St. Paul, Minnesota, **Don Pitts**, water quality specialist, Champaign, Illinois, and **Jeffrey Wheaton**, conservation engineer, Maite, Guam.

The U.S. Department of Agriculture (USDA) prohibits discrimination in all its programs and activities on the basis of race, color, national origin, sex, religion, age, disability, political beliefs, sexual orientation, or marital or family status. (Not all prohibited bases apply to all programs.) Persons with disabilities who require alternative means for communication of program information (Braille, large print, audiotape, etc.) should contact USDA's TARGET Center at (202) 720-2600 (voice and TDD).

To file a complaint of discrimination, write USDA, Director, Office of Civil Rights, Room 326W, Whitten Building, 14th and Independence Avenue, SW, Washington, DC 20250-9410 or call (202) 720-5964 (voice and TDD). USDA is an equal opportunity provider and employer.

---

# Chapter 14

# Water Management (Drainage)

---

## Contents

### Subchapter A—General

---

|                 |   |             |
|-----------------|---|-------------|
| <b>650.1400</b> | <b>Scope</b>  | <b>14-1</b> |
|                 | (a) Need for soil and water management .....          | 14-1        |
|                 | (b) Natural resource and environmental setting .....  | 14-3        |
|                 | (c) Factors affecting drainage .....                  | 14-3        |
|                 | (d) Benefits related to drainage .....                | 14-4        |
|                 | (e) Water quality impacts .....                       | 14-5        |
|                 | (f) Agriculture drainage setting .....                | 14-6        |
|                 | (g) Drainage setting for non-agricultural areas ..... | 14-7        |
| <hr/>           |   |             |
| <b>650.1401</b> | <b>Types of drainage systems</b>                      | <b>14-7</b> |
|                 | (a) Surface drainage .....                            | 14-7        |
|                 | (b) Subsurface drainage .....                         | 14-8        |
|                 | (c) Interception drainage .....                       | 14-8        |
|                 | (d) Water table management .....                      | 14-8        |
|                 | (e) Drainage pumping .....                            | 14-8        |
| <hr/>           |   |             |
| <b>650.1402</b> | <b>Investigations and planning</b>                    | <b>14-9</b> |
|                 | (a) Reconnaissance .....                              | 14-9        |
|                 | (b) Physical surveys .....                            | 14-10       |
|                 | (c) Environmental considerations .....                | 14-13       |
|                 | (d) Decision matrix .....                             | 14-14       |

### Subchapter B—Surface Drainage

---

|                 |   |              |
|-----------------|---|--------------|
| <b>650.1410</b> | <b>General</b>  | <b>14-15</b> |
|                 | (a) Drainage runoff .....                                     | 14-15        |
|                 | (b) Determining drainage runoff .....                         | 14-15        |
|                 | (c) Composite drainage curves .....                           | 14-15        |
| <hr/>           |   |              |
| <b>650.1411</b> | <b>Investigation and planning of surface drainage systems</b> | <b>14-17</b> |
|                 | (a) Field ditches .....                                       | 14-17        |
|                 | (b) Types of open drain systems .....                         | 14-17        |
|                 | (c) Landforming .....   | 14-22        |

|                 |   |              |
|-----------------|---|--------------|
| <b>650.1412</b> | <b>Design of open drains</b>              | <b>14-24</b> |
|                 | (a) Drainage runoff .....                 | 14-24        |
|                 | (b) Drain alignment .....                 | 14-25        |
|                 | (c) Hydraulic gradient .....              | 14-25        |
|                 | (d) Design methods .....                  | 14-27        |
| <b>650.1413</b> | <b>Construction</b>                       | <b>14-37</b> |
|                 | (a) Open drain layout .....               | 14-37        |
|                 | (b) Structures .....                      | 14-37        |
|                 | (c) Watergates .....                      | 14-37        |
|                 | (d) Surface water inlets .....            | 14-37        |
|                 | (e) Berms, spoil banks, and seeding ..... | 14-38        |
|                 | (f) Safety .....                          | 14-39        |
| <b>650.1414</b> | <b>Maintenance</b>                        | <b>14-40</b> |
|                 | (a) Mowing .....                          | 14-40        |
|                 | (b) Burning .....                         | 14-41        |
|                 | (c) Chemicals .....                       | 14-41        |
|                 | (d) Biological .....                      | 14-42        |
|                 | (e) Maintenance of land forming .....     | 14-42        |

### Subchapter C—Subsurface Drainage

|                 |  |              |
|-----------------|--|--------------|
| <b>650.1420</b> | <b>General</b>                                   | <b>14-45</b> |
|                 | (a) Plans .....                                  | 14-45        |
|                 | (b) Soils .....                                  | 14-45        |
|                 | (c) Economics .....                              | 14-48        |
|                 | (d) Use of local guides .....                    | 14-48        |
| <b>650.1421</b> | <b>Applications of Subsurface Drainage</b>       | <b>14-49</b> |
|                 | (a) Field drainage .....                         | 14-49        |
|                 | (b) Interception drainage .....                  | 14-49        |
|                 | (c) Drainage by pumping .....                    | 14-49        |
|                 | (d) Mole drainage .....                          | 14-49        |
|                 | (e) Water table management .....                 | 14-50        |
|                 | (f) Salinity control .....                       | 14-50        |
|                 | (g) Residential and non-agricultural sites ..... | 14-51        |
| <b>650.1422</b> | <b>Investigations and planning</b>               | <b>14-51</b> |
|                 | (a) Topography .....                             | 14-51        |
|                 | (b) Soils .....                                  | 14-51        |
|                 | (c) Biological and mineral clogging .....        | 14-53        |

|                 |   |              |
|-----------------|---|--------------|
|                 | (d) Ground water .....                              | 14-53        |
|                 | (e) Outlets .....                                   | 14-54        |
| <b>650.1423</b> | <b>Field drainage system design</b>                 | <b>14-55</b> |
|                 | (a) Random system .....                             | 14-55        |
|                 | (b) Parallel system .....                           | 14-55        |
|                 | (c) Herringbone system .....                        | 14-55        |
|                 | (d) Drainage coefficient .....                      | 14-55        |
|                 | (e) Hydraulic conductivity .....                    | 14-57        |
|                 | (f) Depth of impermeable layer .....                | 14-59        |
|                 | (g) Depth and spacing .....                         | 14-59        |
|                 | (h) Size of drains .....                            | 14-64        |
| <b>650.1424</b> | <b>Drain envelopes</b>                              | <b>14-71</b> |
|                 | (a) Drain envelope materials .....                  | 14-71        |
|                 | (b) Principles of drain envelope design .....       | 14-74        |
|                 | (c) Design of drain envelopes .....                 | 14-74        |
| <b>650.1425</b> | <b>Materials</b>                                    | <b>14-77</b> |
|                 | (a) Concrete pipe .....                             | 14-77        |
|                 | (b) Thermoplastic pipe .....                        | 14-78        |
|                 | (c) Metal pipe .....                                | 14-80        |
|                 | (d) Vitrified clay pipe (VCP) .....                 | 14-80        |
|                 | (e) Other materials and products .....              | 14-80        |
| <b>650.1426</b> | <b>Appurtenances</b>                                | <b>14-81</b> |
|                 | (a) Surface inlets .....                            | 14-81        |
|                 | (b) Junction boxes .....                            | 14-81        |
|                 | (c) Vents and relief wells .....                    | 14-81        |
|                 | (d) Outlet protection .....                         | 14-83        |
| <b>650.1427</b> | <b>Drain installation</b>                           | <b>14-84</b> |
|                 | (a) Inspection of materials .....                   | 14-84        |
|                 | (b) Storage of materials .....                      | 14-84        |
|                 | (c) Staking .....                                   | 14-84        |
|                 | (d) Utilities .....                                 | 14-85        |
|                 | (e) Crossing waterways and roads .....              | 14-85        |
|                 | (f) Shaping the trench bottom .....                 | 14-87        |
|                 | (g) Laying corrugated plastic pipe (CPP) .....      | 14-87        |
|                 | (h) Drain envelope installation .....               | 14-87        |
|                 | (i) Alignment and joints .....                      | 14-89        |
|                 | (j) Safety and protection during construction ..... | 14-90        |
|                 | (k) Blinding and backfill .....                     | 14-90        |

|  |       |
|--|-------|
| (l) Protection for biological and mineral clogging ..... | 14-90 |
| (m) Checking .....                                       | 14-90 |
| (n) As-built plans .....                                 | 14-90 |

|                                   |              |
|-----------------------------------|--------------|
| <b>650.1428 Maintenance</b> ..... | <b>14-91</b> |
| (a) Jet cleaning .....            | 14-91        |
| (b) Acid solutions .....          | 14-92        |

### Subchapter D—Interception Drainage

|  |              |
|--|--------------|
| <b>650.1430 Interception drainage design</b> ..... | <b>14-93</b> |
| (a) Ground water movement .....                    | 14-93        |
| (b) Location of interceptor .....                  | 14-94        |
| (c) Use of surface or subsurface drains .....      | 14-98        |
| (d) Size of drains .....                           | 14-98        |
| (e) Grades and velocities .....                    | 14-99        |

### Subchapter E—Water Table Management

|  |               |
|--|---------------|
| <b>650.1440 Introduction</b> .....                   | <b>14-101</b> |
| <b>650.1441 Controlled drainage</b> .....            | <b>14-102</b> |
| <b>650.1442 Subirrigation</b> .....                  | <b>14-104</b> |
| (a) General requirements .....                       | 14-104        |
| (b) Planning a water table management system .....   | 14-104        |
| (c) Operation of water table management system ..... | 14-108        |

### Subchapter F—Drainage Pumping

|  |               |
|--|---------------|
| <b>650.1450 Drainage pumping</b> .....                 | <b>14-109</b> |
| (a) Surface drainage pumping conditions .....          | 14-109        |
| (b) Subsurface drainage pumping conditions .....       | 14-109        |
| (c) Relation of pumping plant to drainage system ..... | 14-109        |
| (d) Economic justification of pumping plant .....      | 14-112        |
| (e) Pumping from subsurface aquifers .....             | 14-112        |
| (f) Basic information required for plant design .....  | 14-112        |

|                       |               |
|-----------------------|---------------|
| <b>Glossary</b> ..... | <b>14-119</b> |
|-----------------------|---------------|

| <b>Appendixes</b>   |  |        |
|---------------------|--|--------|
| <b>Appendix 14A</b> | Ditch design tables using                                | 14-143 |
| <b>Appendix 14B</b> | Tables for computing culvert discharge                   | 14-153 |
| <b>Appendix 14C</b> | Salinity monitoring equipment                            | 14-157 |
| <b>Appendix 14D</b> | Auger hole method for determining hydraulic conductivity | 14-161 |
| <b>Appendix 14E</b> | Transient flow method                                    | 14-171 |
| <b>Appendix 14F</b> | Drainage around home sites                               | 14-187 |

| <b>Tables</b>     |   |       |
|-------------------|---|-------|
| <b>Table 14-1</b> | Drainage curves   | 14-16 |
| <b>Table 14-2</b> | Ditch side slopes recommended for maintenance   | 14-28 |
| <b>Table 14-3</b> | Permissible bare earth velocities   | 14-28 |
| <b>Table 14-4</b> | Value of Manning's $n$ for drainage ditch design  | 14-29 |
| <b>Table 14-5</b> | Drainage coefficients   | 14-55 |
| <b>Table 14-6</b> | Maximum trench depths for corrugated plastic pipe buried in loose, fine-textured soils                        | 14-63 |
| <b>Table 14-7</b> | Values of Manning's $n$ for subsurface drains and conduits  | 14-64 |
| <b>Table 14-8</b> | Relationships used to obtain fabric opening size to protect against excessive loss of fines during filtration | 14-76 |
| <b>Table 14-9</b> | Interception drain inflow rates   | 14-98 |

| <b>Figures</b>     |  |       |
|--------------------|--|-------|
| <b>Figure 14-1</b> | Cropland in need of drainage maintenance   | 14-2  |
| <b>Figure 14-2</b> | Field drainage system in need of maintenance   | 14-2  |
| <b>Figure 14-3</b> | Extent of subsurface drainage for a field as shown by infrared photo and interpretive sketch | 14-11 |

---

|                     |   |       |
|---------------------|---|-------|
| <b>Figure 14-4</b>  | Areal application of drainage curves                                    | 14-16 |
| <b>Figure 14-5</b>  | Random drains   | 14-18 |
| <b>Figure 14-6</b>  | Parallel surface drains   | 14-19 |
| <b>Figure 14-7</b>  | Reconstructing cross slope drain system                                 | 14-20 |
| <b>Figure 14-8</b>  | Surface drainage bedding  | 14-21 |
| <b>Figure 14-9</b>  | Earthmoving scraper with laser grade control                            | 14-23 |
| <b>Figure 14-10</b> | Landplane   | 14-23 |
| <b>Figure 14-11</b> | Establishing hydraulic gradeline  | 14-26 |
| <b>Figure 14-12</b> | Surface water inlets  | 14-31 |
| <b>Figure 14-13</b> | Watergate   | 14-32 |
| <b>Figure 14-14</b> | Profile ditch with hydraulic gradient                                   | 14-33 |
| <b>Figure 14-15</b> | Watershed sketch  | 14-34 |
| <b>Figure 14-16</b> | Open drain design worksheet   | 14-35 |
| <b>Figure 14-17</b> | Design profile  | 14-36 |
| <b>Figure 14-18</b> | Main drain with spoil banks spread                                      | 14-38 |
| <b>Figure 14-19</b> | Seeding newly constructed drain   | 14-39 |
| <b>Figure 14-20</b> | Maintenance by mowing   | 14-40 |
| <b>Figure 14-21</b> | Application of chemicals for side slope weed control                    | 14-41 |
| <b>Figure 14-22</b> | Land leveler operation for land smoothing maintenance                   | 14-42 |
| <b>Figure 14-23</b> | Land smoothing equipment  | 14-43 |
| <b>Figure 14-24</b> | Subsurface drain plan   | 14-46 |
| <b>Figure 14-25</b> | Subsurface drain plan and layout  | 14-47 |
| <b>Figure 14-26</b> | Monitoring salinity level of soil-moisture                              | 14-50 |
| <b>Figure 14-27</b> | Estimating soil hydraulic conductivity using soil interpretation record | 14-52 |



---

|                     |   |       |
|---------------------|---|-------|
| <b>Figure 14-28</b> | Soil profile with calculations of hydraulic conductivity using soil interpretation record | 14-52 |
| <b>Figure 14-29</b> | Field drainage systems  | 14-56 |
| <b>Figure 14-30</b> | Curves to determine drainage coefficient, $q$ , for arid areas                            | 14-58 |
| <b>Figure 14-31</b> | Nomenclature used in ellipse equation   | 14-60 |
| <b>Figure 14-32</b> | Graphical solution of ellipse equation  | 14-61 |
| <b>Figure 14-33</b> | Subsurface drain discharge  | 14-65 |
| <b>Figure 14-34</b> | Determining size of corrugated plastic pipe   | 14-66 |
| <b>Figure 14-35</b> | Determining size of clay or concrete drain tile   | 14-67 |
| <b>Figure 14-36</b> | Subsurface drainage system  | 14-68 |
| <b>Figure 14-37</b> | Curves to determine discharge, $Q_r$ , for main drain                                     | 14-70 |
| <b>Figure 14-38</b> | Filter envelope recommendation relative to soil texture                                   | 14-72 |
| <b>Figure 14-39</b> | Typical bedding or envelope installations   | 14-73 |
| <b>Figure 14-40</b> | Junction box and silt trap  | 14-81 |
| <b>Figure 14-41</b> | Blind surface inlet   | 14-82 |
| <b>Figure 14-42</b> | Vents or relief wells   | 14-83 |
| <b>Figure 14-43</b> | Pipe outlet   | 14-83 |
| <b>Figure 14-44</b> | Outlet pipe protection  | 14-83 |
| <b>Figure 14-45</b> | Laser grade control   | 14-84 |
| <b>Figure 14-46</b> | Drain crossings and outlets   | 14-85 |
| <b>Figure 14-47</b> | Dimensions for a 90 degree V groove for corrugated plastic pipe                           | 14-87 |
| <b>Figure 14-48</b> | High pressure jet cleaning  | 14-91 |
| <b>Figure 14-49</b> | Ground water movement   | 14-93 |
| <b>Figure 14-50</b> | Typical interceptor installations   | 14-95 |

---

---

|                     |  |        |
|---------------------|--|--------|
| <b>Figure 14-51</b> | Diversion system on moderate to steep slopes           | 14-96  |
| <b>Figure 14-52</b> | Interceptor drain on bottom land                       | 14-97  |
| <b>Figure 14-53</b> | Water table management alternatives                    | 14-101 |
| <b>Figure 14-54</b> | Water control structures                               | 14-103 |
| <b>Figure 14-55</b> | Field layout of WTM system                             | 14-104 |
| <b>Figure 14-56</b> | Field layout of hydraulic conductivity tests           | 14-105 |
| <b>Figure 14-57</b> | Field layout of hydraulic conductivity test            | 14-106 |
| <b>Figure 14-58</b> | Subirrigation lateral spacing and water table position | 14-107 |
| <b>Figure 14-59</b> | Monitoring water table depth                           | 14-108 |
| <b>Figure 14-60</b> | Pump installation                                      | 14-110 |

---

**650.1400 Scope**

Water management is involved in many aspects of natural resource conservation. It is a broad term used to describe application of water for irrigation, control of excess ponded, and the control of excessive soil moisture. The latter is normally called drainage. Most crops and vegetative material require some drainage to provide a favorable environment in the root zone for growth.

An important distinction must be made between improving drainage of agricultural producing land and converting wetlands. Present agricultural trends are toward intensive use of existing cropland, with much of the emphasis on new management technologies. Maintaining and improving existing drainage and associated yields on wet agricultural soils presently in production minimizes the economic need for landowners to convert wetlands. This encourages a new emphasis on protecting existing wetlands and establishing new wetland areas while maintaining highly productive agricultural land.

This chapter provides guidance during the planning and implementation stages for artificial drainage practices. These stages could involve investigations, surveys, planning, design, specifications, installation, and the operation of the systems for proper water management. Although most of this chapter concentrates on agricultural drainage, which is the management of surface and subsurface water on agricultural and closely related lands, the principles apply to urban conditions as well. This chapter is not intended to provide guidance for large drainage channels.

**(a) Need for soil and water management**

Visual evidences of inadequate drainage include surface wetness, lack of vegetation, crop stands of irregular color and growth, variations in soil color, and salt deposits on the ground surface (figs. 14-1 and 14-2).

The need for agricultural drainage varies considerably because of differences in climate, geology, topography, soil characteristics, crops, and farming methods.

The needed drainage improvements should be determined for each particular site. For example, drainage is needed to complement conservation tillage on naturally wet soils and on some soils that were not excessively wet under earlier tillage practices.

Effective drainage is also important to facilitate good water management where environmental conditions dictate a desire to keep soils wetter longer. With uncertain drainage effectiveness, landowners are more likely to keep water tables lower to prevent flooding of crops during periods of high rainfall. Efficient drainage systems can provide a predictable response to management, providing landowners the confidence to keep water higher longer because of the ability to remove water in a timely fashion.

Ground water drainage can be either natural or artificial. Natural drainage takes place in soils that have a deep hydrological profile and the hydraulic conductivity values are either uniform or increase with depth. Consequently, impermeable soil layers are either absent or located deep. Under such circumstances the ground water table cannot be detected within 6 feet of the ground surface, and artificial drainage is not required.

A lack of natural drainage often causes a high water table and, under some conditions, can cause surface ponding of water. These conditions are the result of a shallow hydrological profile. This indicates the presence of a shallow impermeable layer or that the soil horizon becomes less permeable with depth to the point that percolation is restricted, creating root zone water problems that deter vegetative growth. A high water table and waterlogging in the soil are often prevalent above an impermeable layer when the rate of rainfall or the rate at which water is added exceeds the permeability of this layer. Artificial drainage systems can be installed to remove the excess water and maintain the water table at an appropriate level for the crops or other vegetation to be grown.

Drainage is a practice that can assist in the surface and subsurface management of water. It may be designed to provide numerous benefits other than direct crop benefits. Some additional applications involve:

- Environmental water control for wildlife habitat development or protection.
- Water quality management

**Figure 14-1** Cropland in need of drainage maintenance



**Figure 14-2** Field drainage system in need of maintenance



- Improve site conditions for farmsteads as well as urban and rural communities
- Improve conditions for application of organic wastes
- Control of excess salinity in the root zone.
- Trafficability for farming operations.

Environmental considerations sometimes require careful attention to soil and water management. Water quality control can be facilitated with a properly installed water table management system. Water control for wildlife habitat enhancement, protection, or development can be improved with carefully prepared drainage practices.

### (b) Natural resource and environmental setting

The natural resource and environmental setting in relation to the agricultural drainage system must receive balanced consideration. Drainage systems need to be installed without harming the natural resource and environmental setting. The environmental factors that must receive consideration include:

- Water quality control including both protection and improvement
- Wildlife habitat setting and potential changes because of the drainage
- Wetlands and their preservation or enhancement
- Development of new wetlands in the context of a drainage system
- Mitigation for wetland losses

Water quality is often impacted by agricultural, industrial, mining, and urban development. The drainage system can be the collector and carrier for pollutants; thus water quality considerations are critical to the planning of drainage systems. Because the drainage system is a collection facility, it provides an opportunity to treat or control the discharges. Therefore, the system often must be planned in conjunction with other water quality control facilities.

Wildlife habitat and wetlands are important natural resources. They provide ecological diversity and critical habitat for many species of plants and animals, some of which are rare, threatened, or endangered.

Drainage facilities and other water management systems are planned, installed, and maintained considering wetlands and other land use objectives.

### (c) Factors affecting drainage

The topography, geology, constructed obstructions, or site condition can block or retard water movement and cause poor drainage. Site factors can be placed in several categories and may exist separately or in various combinations. Some of the more important site factors follow.

**Lack of a natural drainageway or other depression to serve as an outlet.** Such sites are common in glaciated, coastal plains and in tidal areas where natural drainage systems are still in the process of development.

**Lack of sufficient land slope to cause water to flow to an outlet, or natural surface barriers that limit the flow of water.** Such sites are: the irregular and pitted surface of glaciated land; depressional areas; and land above dams, constrictions, and natural barriers of valley flood plains.

**Soil layers of low permeability that restrict the downward movement of water trapped in small surface depressions or held in the soil profile.** Many soils have a slowly permeable subsoil, rock formation, or compact (hardpan) layer below the surface either within the normal root zone of plants or at a greater depth. Compact layers can result from human activities (equipment tillage pans) or can occur naturally.

**Constructed obstructions that obstruct or limit the flow of water.** They include roads, fence rows, dams, dikes, bridges, and culverts of insufficient capacity and depth.

**Subsurface drainage problems in irrigated areas caused by deep percolation losses from irrigation and seepage losses from the system of canals and ditches serving the area.** Deep percolation losses from irrigation may fall in the general range of 20 to 40 percent of the water applied. Losses from canals and ditches vary widely and can range from near zero to 50 percent of the water conveyed.

Many soils in arid and semiarid areas have naturally high concentrations of salts. Also soils in arid and semiarid areas may have high water tables, which indicates restricted drainage and leads to salt accumulations. High water tables can be fed by the onsite application of irrigation water, by canal seepage, or by lateral subsurface flows. A primary function of subsurface drainage is to lower and control the water table and keep the salt concentration low in the root zone through leaching. Much of the subsurface drainage work in arid regions is for the control of saline and sodic soil conditions.

Intensive drainage, such as very closely spaced subsurface drains for most soils that have poor internal drainage, is not a cropping problem. Close spacing of drainage-ways on soils in poor condition aids in the establishment and growth of vegetation needed for soil conditioning. The removal of free water in the soil eliminates moisture in excess of that held by soil attraction. Drainage does not remove the capillary water used by growing plants. The depth of the drainageways does control the height of the water table. If the water table is too low in soils that have a low capillary rise, sufficient moisture may not move upward into the root zone. However, this condition is normally desirable in saline and sodic soils that are irrigated.

Special care must be taken with some sandy soils and in most peat and muck areas as they can be overdrained. On peat and muck soils, overdrainage also increases the rate of subsidence of the soil, which can negatively impact existing drainage systems. Maintaining a high water table in organic soils minimizes oxidation and subsidence. These soils are also unique in the particular depth of water table that is best for plant growth. This depth should be considered in designing the drainage system.

### (d) Benefits related to drainage

Removal of free water promotes the soil bacterial action essential for manufacture of plant food by allowing air to enter the soil and consequently improving crop production. Plant roots, as well as soil bacteria, must have oxygen. Drainage aids in soil aeration by providing air space in the soil, which allows water passing downward through the soil to carry out carbon dioxide, thus allowing fresh air to be drawn in.

The economic benefits of drainage are typically portrayed by an increased yield coupled with reduced production costs. Uniformity and vigor of crop growth leads to improved drainage and reduced unit production costs (USDA 1987).

Surface drainage removes ponded water quickly, thereby allowing the remaining gravitational water to move through the soil. Subsurface drainage accelerates the removal of this gravitational water. Thus soils with production constraints caused by wetness can become highly productive. If proper leaching operations are used, subsurface drainage can improve the salt affected soils in arid and semiarid regions.

Andrew Fogiel, working with Harold Belcher at Michigan State University, conducted a literature search on water table management impacts on water quality (Fogiel and Belcher 1991). The study involved 43 published research reports plus 18 research articles. The conclusions were that:

- The impact of water table management practices is primarily on receiving surface water.
- Subsurface drainage systems reduce erosion. Overland flow is reduced while the total surface and subsurface drainage increases at the edge of the field.
- Subsurface drainage results in significant reduction of sediment and pollutants, primarily phosphorous and potassium not in solution.
- Subsurface drainage sometimes results in increased nitrate nitrogen concentrations delivered to receiving water; however, controlling subsurface drainage can reduce the nitrate nitrogen delivered.
- Water table management provides the capability to enhance best management practices that deal with field surface nutrient management and erosion control.
- Subsurface drainage intercepts downward percolating water, which allows for monitoring water quality and providing treatment if needed.
- Water table management practices can contribute to reducing nonpoint pollution alone and with other practices.
- The effect of subsurface drainage on deep ground water quality has not been established because of lack of research and difficulty in monitoring.

- Research is limited on effects controlled drainage and subirrigation have on water quality. These systems have been shown to reduce total flow at the edge of the field and agricultural chemical losses to receiving surface water.

The removal of free water by drainage allows the soil to warm up more quickly because less heat is required to raise the temperature of drained soil. Soil warmth promotes bacterial activity, which increases the release of plant food and the growth of plants. Soil that warms up sooner in the spring can be planted earlier and provide better germination conditions for seeds. Poor surface drainage is shown in figure 14–2.

The removal of ground water improves the conditions for root growth. For example, if free water is removed from only the top foot of soil, crop roots will feed in this confined area. However, if free water is removed from the top 3 feet of the soil, this entire depth is available for plant roots to obtain nutrients and moisture. Removing ground water also reduces the amount of surface runoff, thus reducing erosion and the quantity of sediment and associated nutrients and pesticides leaving the land.

In humid areas, removing excess subsurface water reduces runoff by allowing water intake on a continuous basis and providing room for moisture to be stored in the soil during prolonged rain storms or snowmelt. Soil tilth must also be maintained to allow the continued intake to occur. Subsurface drainage can be a part of the total Resource Management System (RMS) needed to reduce or control erosion.

The removal of excess subsurface water in humid areas can improve trafficability to facilitate the harvesting of nursery stock during the dormant period. Generally, dormancy coincides with the prolonged winter precipitation period. During prolonged periods of intensive rainfall, improved drainage may allow agricultural wastes to be effectively spread on drained pasture, hayland, or cropland, thus reducing the waste storage time. Care must be taken to prevent compaction of the soil when spreading wastes by tractor-drawn equipment during wet periods. Balloon or flotation tires on the equipment effectively minimizes compaction.

## (e) Water quality impacts

Water quality can be enhanced by installation and proper management of controlled drainage systems. The use of control structures in open drainageways to collect sediment benefits downstream surface water by reducing sediment loads and the nutrients and pesticides normally associated with the sediment. Where applicable, control structures in open drainageways or subsurface drainage systems can help to hold a water table close to the ground surface during a noncropping season, which helps to develop an anaerobic condition for denitrification. This can benefit downstream surface and ground water quality.

Drainage systems are not primarily installed as water quality management tools, but they do have an impact on soil and chemical transport. Where it has been necessary to clear and drain land for agricultural production, research has shown that drainage systems can have a positive impact on some nonpoint pollution problems in comparison to agricultural land without drainage. For example, under certain conditions artificial drainage acts to lower soil erosion by increasing the movement of water through the soil profile and thus reducing runoff. However, some research indicates subsurface drainage expedites the transport of nitrate-nitrogen (nitrate-N) from the soil zone to surface water (Fogiel and Belcher 1991) (ASCE 1995).

Based on the published literature, research results on water quality impacts of drainage can be summarized by the following statements that compare agricultural land with subsurface drainage to that without subsurface drainage (Zucker and Brown 1998):

- The percentage of rain that falls on a site with subsurface drainage and leaves the site through the subsurface drainage system can range up to 63 percent.
- The reduction in the total runoff that leaves the site as overland flow ranges from 29 to 65 percent.
- The reduction in the peak runoff rate is 15 to 30 percent.
- Total discharge (total of runoff and subsurface drainage) is similar to flows on land without subsurface drainage, if flows are considered over a sufficient period before, during, and after the rainfall/runoff event.

- The reduction in sediment loss by water erosion from a site ranges from 16 to 65 percent. This reduction relates to the reduction in total runoff and peak runoff rate.
- The reduction in loss of phosphorus ranges up to 45 percent and is related to the reductions in total runoff, peak runoff rate, and soil loss.
- In terms of total nutrient losses, by reducing runoff volume and peak flows, the reduction in soil bound nutrients is 30 to 50 percent.
- In terms of total nitrogen (N) losses (sum of all N species), there is a reduction. However, nitrate-N, a soluble N ion, has great potential to move whenever water moves. Numerous studies throughout the Midwest and Southeast United States and Canada document that the presence of a subsurface drainage system enhances the movement of nitrate-N to surface water. Proper management of drainage water along with selected best management practices (BMP's) help reduce this potential loss.

These results indicate that subsurface drainage is a management tool that reduces the potential for erosion and phosphorus enrichment of surface water from agricultural activities. However, nitrate-N loadings exported from drainage conduits to surface water continue to be a major water quality concern. Agricultural drainage research results related to water quality impacts vary by region of the country; thus the results tend to be region specific, yet they are relevant to similar circumstances. In Ohio State University Extension Bulletin 871 (Zucker and Brown 1998) the basic concepts of water table management are reviewed so the research described for individual states can be better understood.

Another 10-year study in the lower Mississippi Valley that supports the above findings showed that subsurface drainage effectively reduced surface runoff from alluvial soil by an average of 35 percent. Associated reductions in losses were 31 percent for soil, 31 percent for phosphorus, 27 percent for potassium, 17 percent for nitrogen, and about 50 percent for pesticides (Bengtson, et al. 1995).

## (f) Agriculture drainage setting

The agriculture setting for use of drainage systems is codependent and an integral part of the overall management of the cropping system. The setting is critical to the proper crop development as it is the key tool in providing a proper root zone environment for plant growth. The drainage system is the focal point in a well-planned water table management system and is the key component in a proper salinity control system when adequate natural drainage is not present. In humid and tropical climatic zones, it can facilitate the control of pollutants and improve effectiveness of some soil management practices.

### (1) Water table control

Water table control is the operation and management of a ground water table to maintain proper soil moisture for optimum plant growth, to sustain or improve water quality, and to conserve water. Controlled drainage is a method of water table management using water management structures. Supplemental water may be added for subirrigation in addition to controlled drainage. Refer to subchapter E and chapter 10 of NEH part 624 for more information on water table control.

### (2) Managing salinity conditions

Salinity management in coastal areas and in semiarid or arid climates is paramount to the successful agricultural operations of farming enterprises. The provision of artificial drainage in these areas is related to the need for maintaining a proper salt balance in the crop root zone. Water quality concerns often require the separation of drainage water collected from larger groups of farms to provide the opportunity for proper disposal or reuse of the water. Consideration of reuse options, often on more salt tolerant crops, as well as treatment and disposal options must be a part of planning efforts. Onfarm planning considerations, which are primarily aimed at managing the salinity levels in the crop root zone, cannot stop at this point. The effect of reuse, disposal, or treatment must be considered in the framework of an entire system.



### (g) Drainage setting for non-agricultural areas

Drainage for removal of excess water is a practice used in settings other than agriculture under numerous conditions. This practice benefits many recreation areas including sport fields and parking lots. In urban and suburban settings, it is closely related to storm water management, but is also used to facilitate landscaping needs for water management. Buildings and structures often require artificial drainage to provide a stable foundation. Roadways and airfields are other facilities that may require water management systems for drainage. Sliding hillsides and excavated side slopes sometimes require drainage measures to maintain the stability of the slope and protect facilities.

## 650.1401 Types of drainage systems

Drainage is accomplished by establishing or accelerating water removal or water table management within the site, by diverting offsite surface or subsurface flows, or by a combination of these. Even though most references relate to agricultural settings, the applicability includes urban areas.

Field drainage systems, whether surface or subsurface, generally remove excess irrigation water, leaching water, storm runoff, snowmelt, excess rainfall occurring on the site, or overland flows. Surface water generally is removed by a combination of practices of open ditches, land forming, and underground outlets. Subsurface flows are removed or controlled by open ditches or buried conduits. A lateral drain or system of lateral drains are generally located to lower the water table. The alignment of the drains depends somewhat on costs, topography, design grades, and outlet conditions.

### (a) Surface drainage

Surface drainage involves removal of excess surface water by developing a continuous positive slope to the free water surface or by pumping. It may be accomplished by open ditches, land grading, underground outlets, pumping, or any combination of these that facilitates water movement to a suitable outlet. Drainage by this method applies to nearly level topography where:

- Soils are slowly permeable throughout the profile.
- Soils are shallow, 8 to 20 inches deep, over an impermeable layer.
- Topography consists of an uneven land surface that has pockets or ridges which prevent or retard natural runoff.
- Surface drainage supplements subsurface drainage.

---

### (b) Subsurface drainage

Subsurface drainage is the removal of excess ground water within the soil profile. It is also used to facilitate the leaching of salts from the soil and maintenance of a salt balance. Plastic tubing, clay and concrete tile, and mole drains are used in many cases. Open ditches constructed to an adequate depth and properly located may also be used. Subsurface drainage is applicable to wet soils having sufficient hydraulic conductivity for drainage where a suitable outlet is available or an outlet can be obtained by pumping.

### (c) Interception drainage

Interception drainage systems remove excess water originating upslope, deep percolation from irrigation or rainfall, and water from old, buried stream channels. Interception drains are open ditches or buried conduits located perpendicular to the flow of ground water or seepage. They are installed primarily for intercepting subsurface flow moving downslope. Although this method of drainage may intercept and divert both surface and subsurface flows, it generally refers to the removal of subsurface water.

### (d) Water table management

Water table control systems can be an alternative to single purpose drainage systems. The basic premise is to install certain structural measures and to operate them in a manner that controls the water table at a predetermined elevation. The structural practices can range from installing a flashboard or stoplog structure in the outlet ditch to installing a complete system consisting of land forming, subsurface drain tubing, water control structures, well and pump to provide supplemental water, and observation wells for monitoring.

### (e) Drainage pumping

Pumps or pumping systems have many applications in drainage systems. Pumps may be used as outlets for surface or subsurface drainage when gravity outlets are not available or the available outlet is not deep enough to satisfy minimum depth requirements. A more complete write-up than that in this chapter is in the National Engineering Handbook Part 624 (Section 16) (SCS 1971).

Pumps for water supply are often needed for sub-irrigation or water table management systems. Wells and pumps for wells are also described in NEH Part 623 (Section 15) and Part 650 EFH (chapter 12).

## 650.1402 Investigations and planning

When drainage is considered, an investigation is necessary to determine the feasibility of the project. The investigation should provide a clear understanding of the problem, the kinds and amounts of practices necessary, and an estimate of the cost and expected benefits and impacts of the project.

This information often can be obtained from a reconnaissance of a small problem area. More detailed examinations and surveys are made where the size of the area, lack of defined drainage pattern, or such special situations as riparian vegetation, wetlands, or rock outcrops may require. Environmental considerations must be a part of the planning process and investigations necessary for habitat enhancement or mitigation and for environmental protection should be an integral part.

### (a) Reconnaissance

The first step in analyzing the problem is to visit the area proposed for drainage. Wetland determinations are to be made if not readily available. Determinations related to cultural resources and endangered or threatened species of flora and fauna for the region should also be investigated. If a standard soil survey map of the area is available, it is a valuable source of information. The investigator should walk over the area and become acquainted with the problems, topographic conditions, and physical features. The ideal time to do this is immediately after an intensive rainfall or an irrigation application. The investigator can mark low areas and other important features on a map while in the field. Some field surveys may be needed to identify or locate low areas.

Special emphasis must be given to ground water investigations for subsurface drainage and water table control systems. The primary purpose of such water management is to lower and control water table levels. At the time of the reconnaissance, a determination is made of the average or usual depth to the water table, as well as the water table level during the growing season. Landowners and operators may have a good

estimate of water table levels based on their farming experience. In the absence of such information, local wells can be checked and, if necessary, a few borings can be made at selected locations to get some estimate of water table levels. If a high water table does exist and subsurface drainage or water table control is recommended, a more detailed investigation is required before planning and designing a system.

The vegetative cover should be observed and associated with certain ranges of water table levels or surface ponding. Willow, cottonwood, and poplar trees often thrive in high water areas. Grasses, such as reed grasses and sedges, are generally in these areas, as are many other hydrophytic plants and weeds. The presence of hydrophytic vegetation that typically occurs in wet areas may indicate that a wetland is on the site. The Natural Resources Conservation Service is committed publicly and by policy to help protect wetlands; therefore, technical assistance to plan and install or improve drainage systems on wetlands can be provided as outlined in the National Food Security Act Manual (NFSA Manual).

Maps, a hand level, and a soil auger should be used in the reconnaissance. A standard soil survey report, aerial photographs, and county and USGS survey maps are helpful sources of information. They are useful as a guide in recording data, such as soil information, limits of areas to be improved, location of outlets, natural and artificial channels and improvements, probable location of proposed improvements, general land slopes, channel slopes, wetlands to be protected, and watershed boundaries. Pacing or scaling from a map and hand level shots provide a means of estimating approximate channel grades, depths, and sizes. The soil auger, with extensions, provides a means of making essential subsoil examinations and determining water table levels at depths commonly needed for most sites.

The following items should be noted:

- Location and extent of any wetlands.
- The areas in which crops show damage, as pointed out by the farmer, indicated by the aerial photograph, or noted in personal observations.
- Personal observations of unique landscape features, ecologically significant areas, land use patterns, operation (land management) aspects, and site visibility.

- Topography and size of the watershed area.
- Size, extent, and ownership of the area being considered for drainage.
- Location of the drainage outlet and its condition.
- Location, condition, and approximate size of existing waterways.
- Presence of cultural resources.
- Potential impacts outside the area being evaluated.
- General character of soil throughout the area needing drainage, including land capability, land use, crops and yields, and salinity or sodicity.
- High-water marks or damaging floods and dates of floods.
- Utilities, such as pipelines, roads, culverts, bridges, and irrigation facilities and their possible effect on the drainage system (see NEM part 503).
- Sources of excess water from upslope land or stream channel overflow and possible disposal areas and control methods.
- Condition of areas contributing outside water and possible treatment needed in these areas to reduce runoff or erosion.
- Condition of any existing drainage system and reasons for failure or inadequacy. Old subsurface drainage systems that have failed because of broken or collapsed sections may well be the cause of a wet area.
- Estimate of surveys needed.
- Type and availability of construction equipment.
- Feasibility.

For small jobs, this information may be obtained by the technician who goes over the land with the landowner. The technician can then obtain engineering and other survey data.

The intensity of this investigation and the makeup of the investigation party depend upon the size of the area and complexity of the problem. In all cases, as much information as possible should be obtained from local farmers and residents. The investigation must be extensive enough to provide a clear picture of the size and extent of the drainage problem.

## (b) Physical surveys

The size and complexity of the area to be drained determines the kinds and number of surveys needed. For the smaller, simpler jobs, the technician may only need a few elevations at key locations and make a few soil borings to determine soil texture, water table levels, and the need for subsurface drainage. Determine the approximate drainage area, and estimate the approximate cost.

The seasonal considerations of field surveys is important. The dormant period versus cropping and/or irrigation season are major periods to evaluate. Weather patterns and significant rainfall/runoff events should also be evaluated.

Concepts for physical surveys have dramatically improved in recent years. Laser levels, Geographic Information Systems (GIS), and Global Positioning Systems (GPS) are now common tools to modernize and simplify the physical surveys required for investigation and planning related to maintaining drainage systems. These tools can facilitate the proper development of field information to protect valuable wetland or other habitat areas when working on the maintenance of drainage systems. Information needs for the drainage system are detailed in this section. The most efficient tools to use in obtaining proper and thorough data require judgment and responsibility to assure the information obtained presents the environmental picture in perspective with other resource and development improvement suggestions.

Figure 14–3 represents an infrared photograph and interpretive sketch showing the extent of subsurface drainage for a field. The infrared method appears to be a promising and cost effective tool as compared to conventional probe methods. The drain mapping procedure is based on the fact that the soil over subsurface drains dries faster than other soil. This changed moisture condition is shown by a difference in the infrared reflectance. A sketch as shown in figure 14–3 may be developed using a GIS process.

Modern laser surveying equipment is readily available and improves efficiency for obtaining the field survey information. Laser leveling has also been used with drainage trenchers for automatic grade control since the 1960's (USDA, ERS 1987). GPS facilitates the

mapping of existing drainage facilities, which also contributes to the efficiency and effectiveness of planning work (Farm Journal 1997). GIS data bases are becoming more common, and the availability of this information can greatly enhance the detail and scope of investigation and planning actions without adding a great deal of extra time. GIS data and systems can provide considerable environmental information and facilitate presentations of planned alternatives. The use of these tools truly helps to make the thorough investigations needed for comprehensive planning alternatives and guidance (FAO 1988).

The objective of a survey for design purposes is to obtain elevations, topography, and other field information necessary to design the system and prepare plans, specifications, and estimates of quantities of work to be performed. Only the field information needed for this purpose should be gathered.

### (1) Drainage outlet

The first major engineering survey job is to determine the location and adequacy of the drainage outlet. Enough level readings and measurements should be made to reach a sound decision. The proper functioning of the entire drainage system hinges upon this point. The following requirements should be met in determining adequacy of outlets:

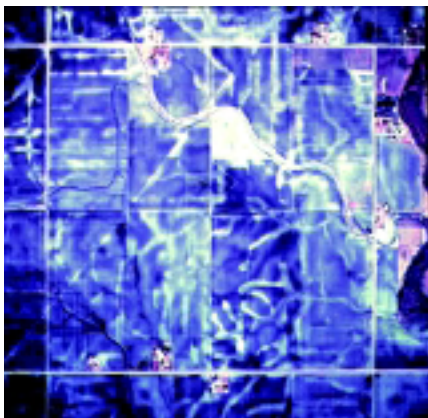
- The depth of outlet should be such that any planned subsurface drains may be discharged above normal low waterflow. Pumping may be considered as a last alternative.

- The capacity of the outlet should be such that the design flow can be discharged at an elevation at or below the design hydraulic gradeline. If the outlet is a channel, the stage-discharge relationship should be determined taking into consideration the runoff from the entire watershed.
- The capacity of the outlet also must be such that the discharge from the project are will not result in damaging stage increases downstream of the project.
- The quality of drainage water and its impact on downstream areas should be considered.
- Submerged outlets may in some cases be desirable. Special care must be taken to obtain the desirable drainage on the cropland, yet keep the outlet free of undesirable vegetation, sediment, and rodent entry. This situation may also be a common practice in tidal areas where the daily water surface fluctuation allows free discharge part of the time and submergence part of the time. Spacing and depth of a drainage system would need to be adjusted to recognize this condition.

### (2) Topographic survey

Topographic information of the area to be drained must be obtained. This information is used in the flatter areas for planning land forming or for locating field ditches, drains, or other facilities.

**Figure 14-3** Extent of subsurface drainage for a field as shown by infrared photo and interpretive sketch (photo: Champaign County Soil and Water Conservation District and the Agricultural Engineering Department, University of Illinois)



The amount and kind of topographic surveys depend upon the drainage problem and the topography of the land. The surveys vary from a detailed grid or contour map to random elevations, valley cross sections, and location of important features. The type of grade control equipment used by local contractors, such as laser, should be considered in determining the need for topographic surveys. Refer to EFH, Chapter 1, Engineering Surveys, for survey procedures. Some recommended details to observe in obtaining topographic information for drainage include:

- Obtain elevations at 100 to 300 foot horizontal intervals on flatland, depending on how nearly level the land is and whether the drainage pattern is apparent from inspection. Take additional elevations in all low or depressed areas. The flatter the land, the more important it may be to take elevations at relatively close intervals.
- Where random ditches are to be used to drain depressions or pockets, the amount of survey data should be varied according to ground conditions. Elevations at close intervals will be necessary if depressed areas are numerous, whereas a few random shots may suffice for areas that have few depressions. In either case the survey should be made in sufficient detail to locate and determine elevations of depressed areas and the best outlets.
- Physical features of adjacent land should be specified if they affect the drainage of the proposed area. The information should include the location and elevation of the bottom of drainageways, the size of opening and flow line elevations of culverts and bridges, and any other similar information needed to plan the drainage system.

### (3) Profile survey

The procedure for running profiles is described in EFH, Chapter 1, Engineering Surveys. Slightly different procedures are required if an existing ditch is used or if a new ditch is being considered. The following steps must be followed for profiles where a ditch already exists:

- Obtain elevations of the old ditch bottom natural ground at 100 to 500 foot intervals along the ditch. Elevations of critical points between stations should also be taken. A critical point may be either a high point or a low point that would affect design or system cost.

- On existing culverts and bridges along the ditch line, obtain the station, inlet and outlet invert elevations, size of culvert (or size of opening if different), length, alignment angle with the ditch, and kind of material (concrete, CMP). Also, obtain elevations of top of road crossing or structures and, in the case of bridges, the elevation of the bottom of stringers. Where bridges will be affected, note the elevation of the bottom of the top footings and of the bridge piers and abutments along with their condition.
- Where laterals or tributaries discharge into the ditch, note the station and the bottom elevation of the ditch at the point of entrance and any other pertinent data that would be useful in design.
- Locate, describe, and obtain elevations as required or any other physical features along the ditch that will affect the design, such as cattle ramps, fences, surface flow entering ditch, and rock outcrops.
- Obtain soil information for channel stability considerations.

Profiles on new ditch lines may differ from profiles of existing ditches. Information and elevations along the proposed ditch line should be obtained as specified for existing ditches.

### (4) Cross sections

A detailed procedure for surveying cross sections is described in EFH Chapter 1, Engineering Surveys. Some guidelines include:

- Individual shots should be taken at all prominent breaks to accurately reflect the ground surface.
- Cross sections should be taken at intervals of 100 to 500 feet on existing ditches, depending on the irregularity of topography and the variation in ditch size. Cross sections may show elevation and extent of low areas needing drainage if this information was not obtained by the preliminary profiles. Other needed information is location of utilities, fence lines, roads, land use, and existing landscape features (trees, vegetation) that may affect construction or future maintenance.

### (5) Other field information

Other field data that should be gathered at the time of the design survey include:

- The area to be drained delineated on an aerial photograph or other suitable map.
- The drainage area.
- The crops to be grown and farm machinery to be used after drainage.
- Soil borings to a depth of at least 1 foot below the proposed depth of the ditch (unless the characteristics of the soil materials are known for areas in need of surface drainage) and to twice the depth of drain where subsurface drainage is needed.
- Information on frequency and depth of flooding. Drift marks of previous flooding can be seen on trees, culverts, or fence posts. Elevation and frequency of high water should be obtained if it will have a bearing on the ditch design.

For more information, see EFH Chapter 1, Engineering Surveys, and EFH Chapter 5, Preparation of Engineering Plans.

### (c) Environmental considerations

The environmental values of an area must be fully considered when planning to develop a new drainage system or improve an existing system. Alternatives and options should be evaluated from the perspective of the landowner, neighbors, and the community. Alternatives should aim towards balanced and sustainable systems that fit within the natural setting. The action to be taken or that is proposed will be open to the scrutiny of others, and decisionmakers should be aware of potential impacts for each alternative. Agricultural developments, natural resource conservation, biodiversity, wildlife habitat, water quality, economics, health, and social considerations may all play a role in the decisionmaking process, and appropriate evaluations should be made.

#### (1) Water quality

Installation or maintenance of drainage systems can cause changes to the associated ecosystem, thus care must be taken to consider the options and to know the adverse and beneficial impacts of actions proposed.

The reuse of drainage water can be noted in the salinity control section of this chapter, Applications of Subsurface Drainage. In-depth information on salinity assessment and management is in ASCE Manual 71 (ASCE 1990). Other documents that describe overall water quality issues include *Management Guidelines for Agricultural Drainage and Water Quality*, published by the United Nations Food and Agriculture Organization and the International Commission on Irrigation and Drainage (FAO 1997). These documents describe the potential for toxic materials in drainage water and reflect on options for controlling potential pollution substances in drainage water.

Research has demonstrated a strong linkage between subsurface drainage and nitrate-N losses to surface water. An obvious, but less economical method to reduce nitrate-N losses is to abandon subsurface drainage systems. The practicality of this method is minimal, however, as crop production would be reduced substantially on millions of acres of productive poorly drained soils in areas similar to the Midwest Region. In addition, sediment and phosphorus concentrations in surface water would increase. Research conducted in the North Central Region (Zucker and Brown 1998) suggests the following strategies would minimize nitrate-N loss to surface water:

- Implement wetland restoration areas, denitrifying ponds, or managed riparian zones where drainage water could be "treated" to remove excess nitrate-N before discharge into drainage ditches or streams.
- Design new subsurface drainage systems or retrofit existing drainage systems to manage soil water and water table levels through controlled drainage or subirrigation, lowering concentrations of nitrate-N in shallow ground water. The cost of retrofitting existing systems for subirrigation must be compared to the benefit of increased yields.
- Use alternative cropping systems that contain perennial crops to reduce nitrate-N losses. Obtaining a market and a satisfactory economic return presents some barriers.
- Fine tune fertilizer N management. Research shows that applying the correct rate of N at the optimum time substantially affects the reduction of nitrate-N losses.

- Improved management of animal manure would contribute to lowering nitrate-N losses in livestock-producing areas. Knowing the nutrient content and application rate of the manure, spreading it uniformly, and incorporating it in a timely manner would all lead to better management and confidence in manure N as a nutrient source.

### (2) Wetlands

Drainage systems impact on wetlands is an ever increasing concern. Drainage equations and water movement relationships can be used to assess impacts to wetland hydrology by artificial drainage. NEH, Part 650, Chapter 19, Hydrology Tools for Wetlands Determination, describes the hydrology tools or procedures for evaluating hydrology related to wetlands and appropriate distance for safe installation of subsurface drainage systems relative to location of wetlands.

### (3) Permits

Required permits and regulatory issues must also receive careful attention. The information for these documents or reports is frequently gathered from a multitude of sources, and new field data may be needed to develop proper analytical documentation.

### (d) Decision matrix

Numerous environmental impact assessment suggestions are available and provide guidance in developing a decision matrix. The decision matrix can be a critical tool for helping decisionmakers review options and reach agreements on work that is to be done. In the planning process, a number of alternative plans must be developed. The first alternative is generally to do nothing, and then more elaborate alternatives are developed that may be increasingly more complex or more expensive. Each of these alternatives has varying degrees of positive or negative impact on a selected list of evaluations. A typical list of evaluation factors includes:

- Reduce wetness impact to crops
- Timeliness of field operations in wet areas
- Minimize impact to downstream landowners
- Economics
- Water quality
- Biodiversity and wildlife habitat
- Permits and regulatory issues
- Soil quality and soil erosion
- Wetland values
- Social issues

One or more tables should be developed to display results of the impacts on the selected factors for each alternative plan. These tables or possible graphic displays benefit the decisionmaking process while working with concerned individuals or groups.



## 650.1410 General

Surface drainage is needed in flatland areas where water floods over the land. Slopes in these areas generally are not great enough for the flowing water to cause erosion; therefore, the object of drainage systems in flatland areas is to remove the excess water before it damages crops. This differs from erosion control work in which the object is to control the erosive velocity of peak flood flows.

When improving soils that have very low permeability or reclaiming highly salt affected soils that need drainage, the use of open drains has a practical installation advantage over pipe drainage. At a later stage when the structure of these soils improves and their hydraulic conductivity values become relatively stable, cost effective subsurface pipe drains can be considered.

### (a) Drainage runoff

Ditches for drainage of common field crops generally are designed to remove runoff from the drainage area within a 24-hour period following a rain event. Some surface flooding of the land during this period is permissible.

Some high-value and specialty crops require a more rapid rate of removal of runoff to prevent crop damage. For these crops, a 6- to 12-hour removal interval may be necessary during the growing season.

The drainage coefficient, is the rate of water removal per unit of area used in drainage design. For surface drainage the coefficient generally is expressed in terms of flow rate per unit of area, which varies with the size of the area.

### (b) Determining drainage runoff

Curves for determining runoff for drainage design have been prepared for most of the humid areas of the United States. The curves are based on the climate, soils, topography, and agriculture of the particular area. Curves developed by John G. Sutton, known as the SCS drainage runoff curves have been used in the

Northern States since the 1930's. The Red River Valley runoff curves, based on the SCS drainage runoff curves and adjusted to the Red River Valley of the North, have been in use for about the same period.

Other drainage curves have been developed for use in the Southeastern, Southwestern, and Western States. Because of the wide variations in rainfall, soils, crops, and topography, drainage design should be based on drainage coefficients applicable to local conditions. The capacity for design given by most of the curves varies in accordance with the general formula (Cypress Creek equation):

$$Q = CM^{0.83}$$

where:

$Q$  = flow in ft<sup>3</sup>/s for which the drain is to be designed

$C$  = the appropriate drainage curves

$M$  = area in mi<sup>2</sup> of watershed

The drainage curves mentioned provided data to develop table 14-1, which facilitated the application of the Cypress Creek equation on a national basis.

This equation provides an economical and effective design for open ditches if  $C$  is selected properly. See table 14-1 and figure 14-4, State standards and specifications or local drainage guides for  $C$  values to be used.

The capacity for drainage ditches in arid, irrigated areas is generally determined by the leaching requirement and amount of return flow from irrigation water. If surface runoff from precipitation is involved, the above formula with the appropriate value of  $C$  may be used. For many ditches in these areas, the depth rather than the capacity required governs the size of the drain.

### (c) Composite drainage curves

Composite curves are used where runoff from the land draining into an open drain must be based on different drainage curves. The design capacity of ditches in these areas can be determined by computing equivalent drainage area information. Using this method, you determine the runoff from the acreage of one type of

**Table 14-1** Drainage curves

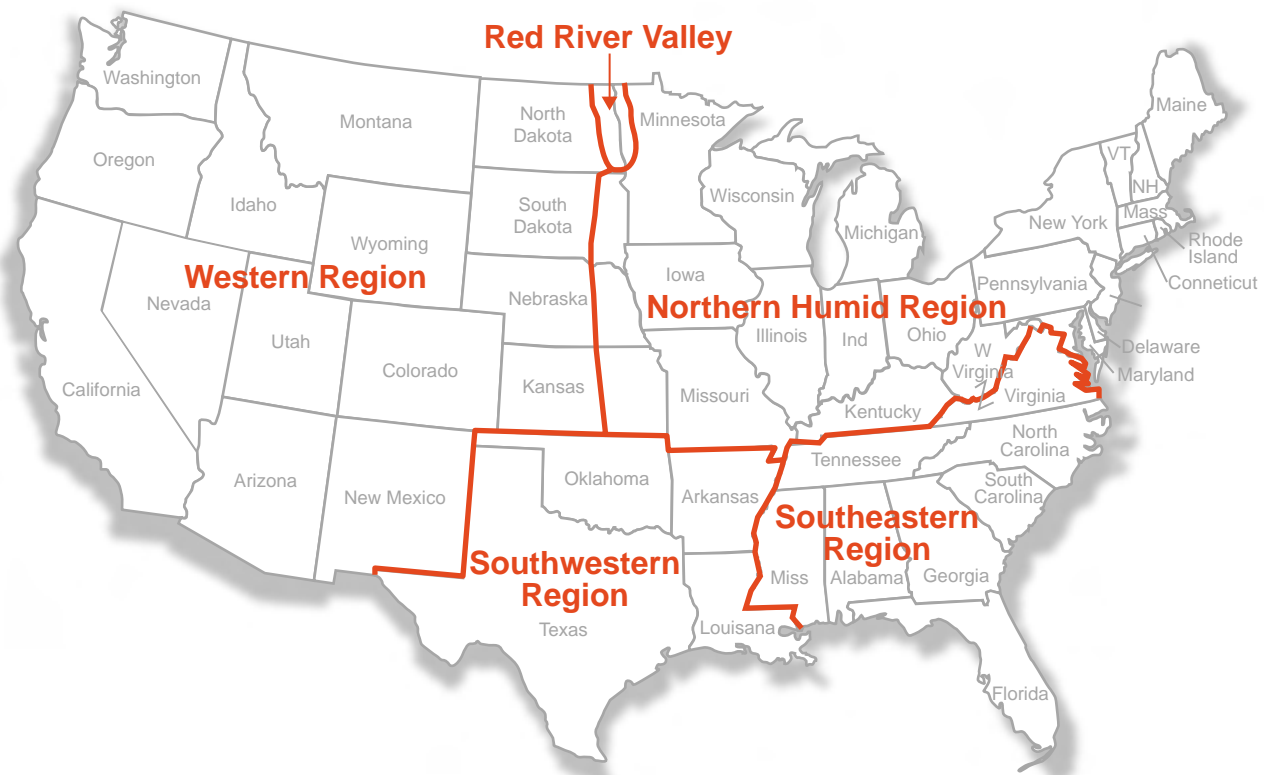
| Region                     | Land use                   | Drainage curves (C) |
|----------------------------|----------------------------|---------------------|
| Northern humid region      | Pasture                    | 25                  |
|                            | Cultivated (grain crops)   | 37                  |
| Southeastern region        | Woodland (coastal plain)   | 10                  |
|                            | Pasture (coastal plain)    | 30                  |
|                            | Cultivated (coastal plain) | 45                  |
|                            | Cultivated (delta)         | 40                  |
|                            | Riceland                   | 22.5                |
| Red River Valley (MN & ND) | Cultivated                 | 20                  |
| Southwestern region        | Rangeland                  | 15                  |
|                            | Riceland                   | 22.5                |

Western region \*

\* Capacity for open drains is generally determined by leaching requirements and amount of return flow from irrigation water. If surface runoff from precipitation is involved, the Cypress Creek equation may be used with a value of C from the applicable state drainage guides.

**Note:** The drainage curves for the Cypress Creek equation ( $Q=CM^{0.83}$ ) have provided economical and effective design values for open drains in the indicated areas of the United States (Source: NRCS NEH 16).

**Figure 14-4** Areal application of drainage curves



land and convert it to the equivalent acreage of another type of land so that the acreage may be added together and used to find the discharge from the area.

### Example

A watershed contains 500 acres of land requiring the runoff curve  $Q = 45 M^{0.83}$  and 200 acres of land requiring the runoff curve  $Q = 22.5 M^{0.83}$ . Either the  $Q = 45 M^{0.83}$  or  $Q = 22.5 M^{0.83}$  curve must be converted, depending on the curve to be used on land below this watershed.

Assume the removal rate of this land is  $Q = 45 M^{0.83}$ . The discharge from 200 acres on the  $Q = 22.5 M^{0.83}$  curve is  $8.4 \text{ ft}^3/\text{s}$ . This is about 86 acres on the  $Q = 45 M^{0.83}$  curve. The total equivalent watershed would be 500 acres plus 86 acres, or 586 acres. The total discharge from 586 acres on the  $Q = 45 M^{0.83}$  curve is  $42 \text{ ft}^3/\text{s}$ . Therefore, 586 acres and 42 cubic feet per second are used in computations below this watershed.

## 650.1411 Investigation and planning of surface drainage systems

A surface drainage system may consist of field ditches and/or land forming with ditches and underground pipes to carry the drainage water to the outlet. The drainage system should provide for an orderly removal of excess water from the surface of the land.

Open drains may serve any land use. In urban uses they are typically called open drains or surface storm drains, while in agricultural fields they are usually referred to as ditches.

Current legislation and regulations require care to avoid environmental damage to existing wetlands. Maintenance of drainage systems is critical to the sustainability of agriculture and for other land uses.

### (a) Field ditches

Field ditches are shallow ditches for collecting and conveying water within a field. They generally are constructed with flat side slopes for ease in crossing. These ditches may drain basins or depressional areas, or they may collect or intercept flow from land surfaces or channeled flow from natural depressions, plow furrows, crop row furrows, and bedding systems. State drainage guides and standards and specifications have criteria regarding side slopes, grades, spacing, and depth of drainage field ditches.

### (b) Types of open drain systems

Drains should be located to fit the farm or other land use operations and should have capacity to handle the runoff and not cause harmful erosion. The drain system should cause excess water to flow readily from the land to the disposal drain. Five common drain systems are described in this section.

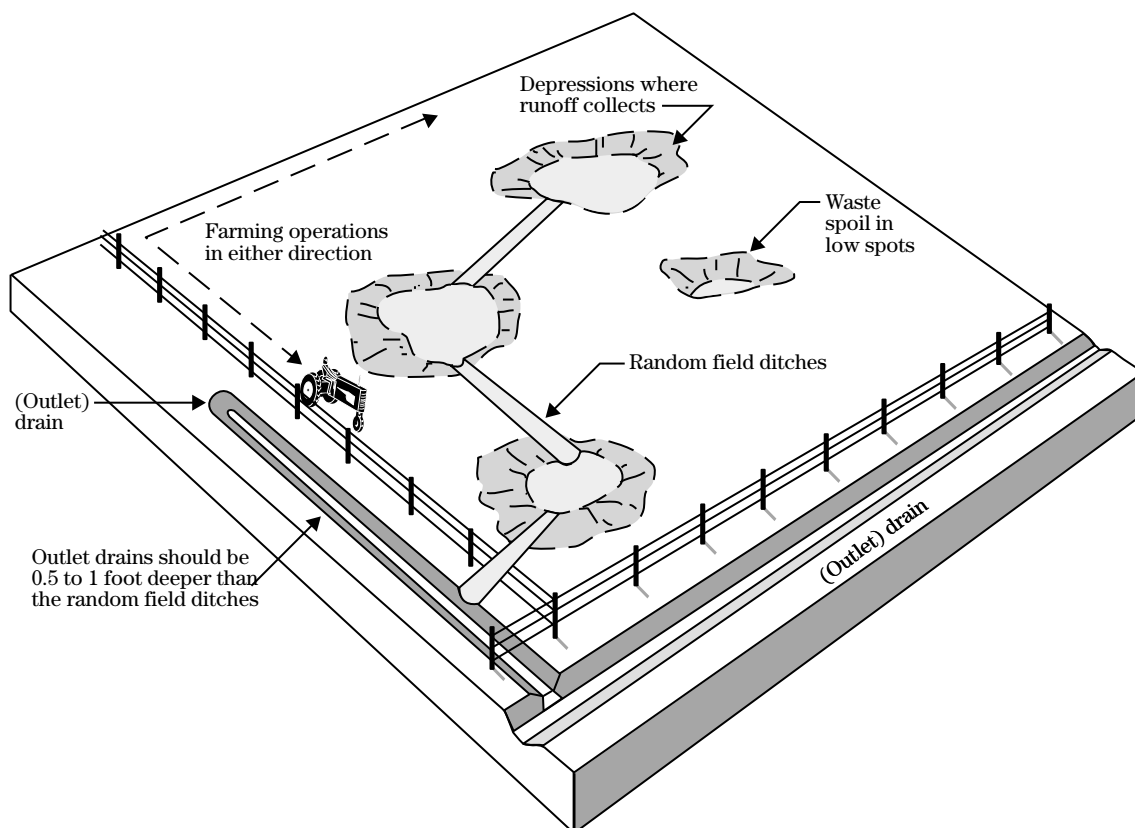
### (1) Random drain system

This type system is adapted to drainage systems on undulating land where only scattered wet areas require drainage. The ditches should be located so they intercept depressions and provide the least interference with farming operations (fig. 14-5). The ditches should be shallow and have side slopes flat enough for farm equipment to cross. Precision land forming and smoothing help to assure the removal of surface water from less permeable soil.

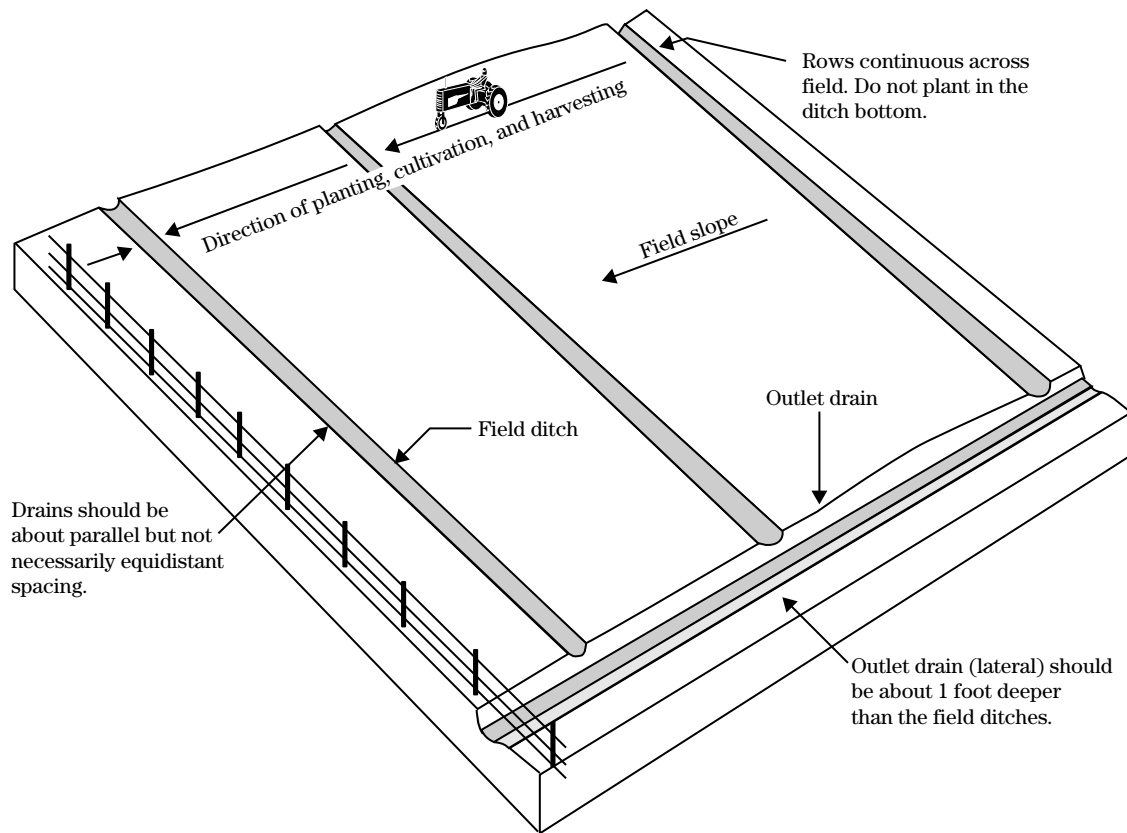
### (2) Parallel drain system

This type system is applicable to land where the topography is flat and regular and where uniform drainage is needed. The ditches are established parallel but not necessarily equidistant, as shown in figure 14-6. The direction of the land slope generally determines the direction of the ditches. Field ditches are generally perpendicular to the slope, and laterals run in the direction of the slope. The location of diversions, cross slope ditches, and access roads for farming equipment can also influence the drain location. Spacing of the field ditches depends upon the water tolerance of crops, the soil hydraulic conductivity, and the uniformity of the topography. Landforming can reduce the number of ditches required by making the topography more uniform. Where possible, spacings should be adjusted to fit the number of passes of tillage and harvesting equipment.

**Figure 14-5** Random drains



**Figure 14-6** Parallel surface drains

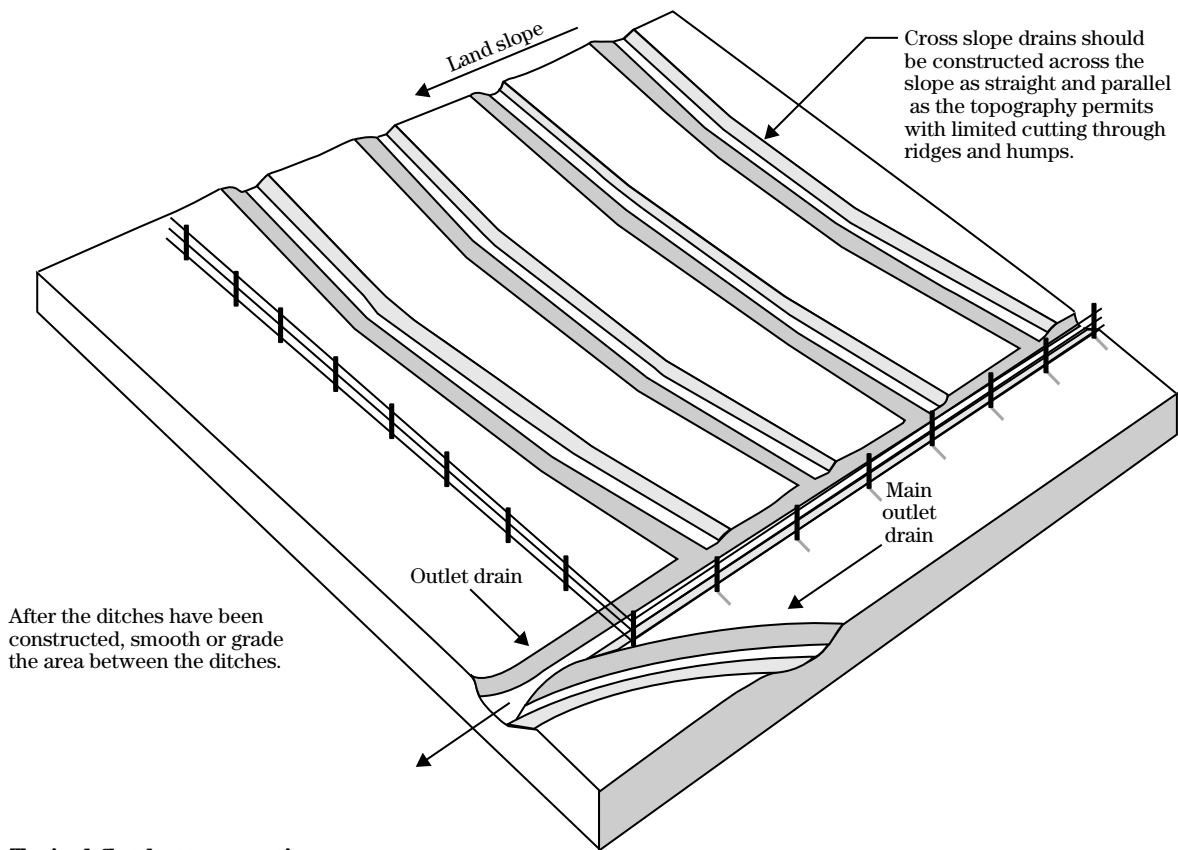


**(3) Cross slope drain system**

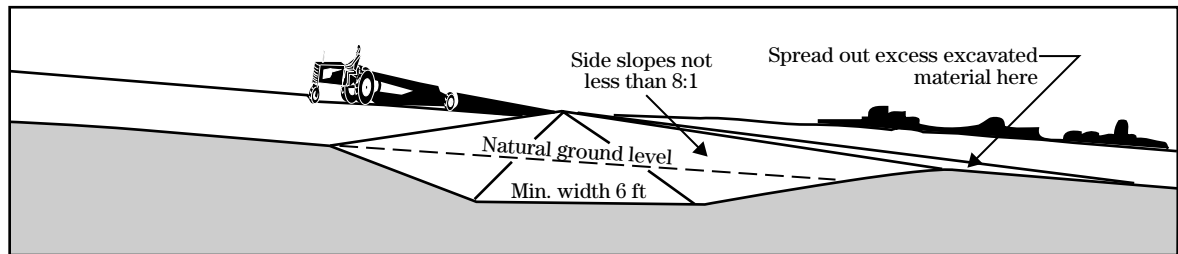
This system is used to drain sloping land, to prevent the accumulation of water from higher land, and to prevent the concentration of water within a field. The

field ditches work best on slopes of less than 2 percent. The drain is located across the slope as straight as topography will permit (fig. 14-7). The spacing of these ditches varies with the land slope and should be

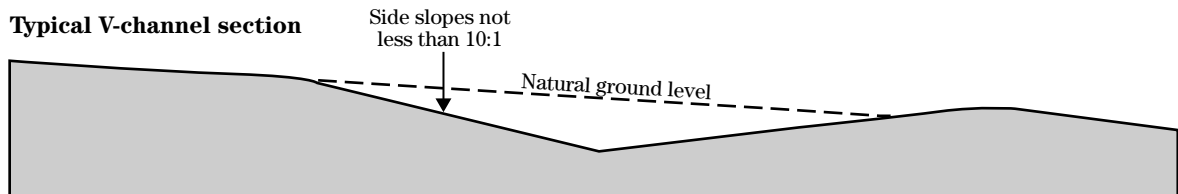
**Figure 14-7** Reconstructing cross slope drain system



**Typical flat bottom section**



**Typical V-channel section**



based on State drainage guides. The excavated material should be placed in low areas or on the downhill side of the drain. Landforming or smoothing between the ditches improves operation of the system by preventing the concentration of flow and the occurrence of ponding.

#### (4) Bedding

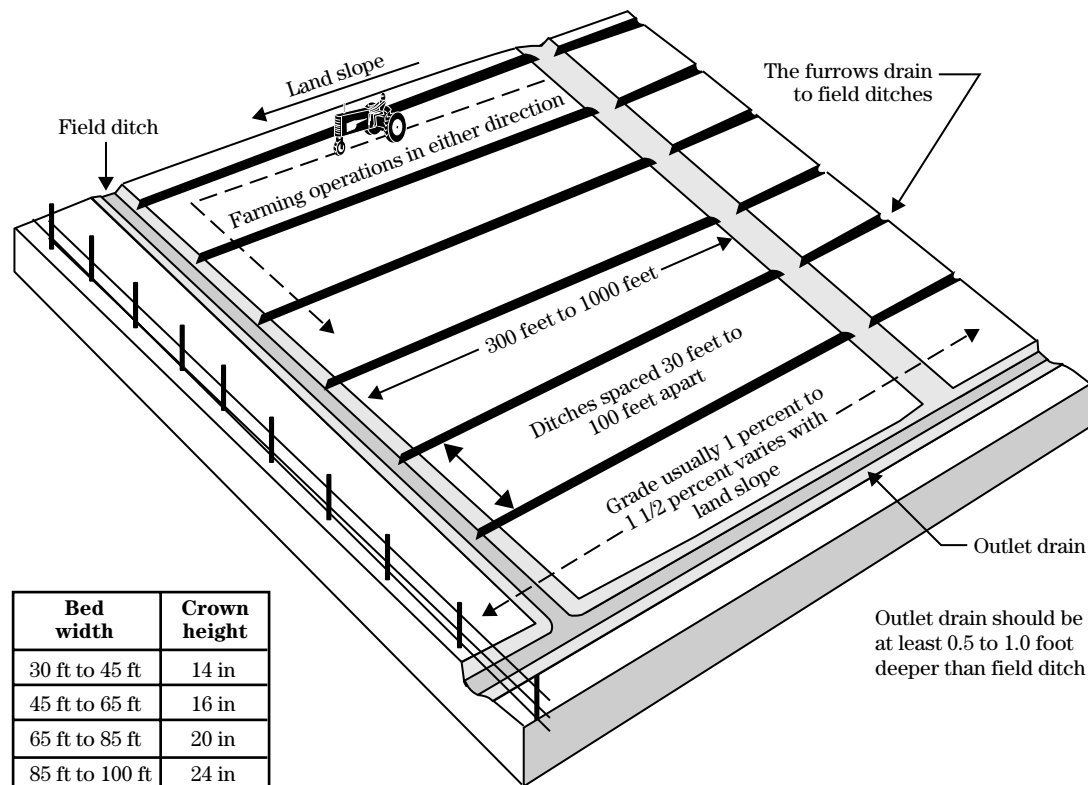
Bedding resembles a system of parallel field ditches with the intervening land shaped to a raised, rounded surface (fig. 14–8). This drainage system generally is used where slopes are flat and the soil is slowly permeable and where other types of drainage are not economically feasible. A bedding system generally is in small land areas and is installed using farm equipment.

Beds are established to run with the land slope or in the direction of the most desirable outlet. Local information should be used to determine the width of beds, the crown height, construction method, and maintenance.

#### (5) Narrow raised beds

A narrow bed system has a raised bed wide enough for single or double cropping rows to provide an aerated surface profile. This system facilitates surface water movement and aeration of the shallow root zone. When used with plastic covers for weed control, evaporation control, and nutrient management, the narrow bed system can be extremely effective for some cropping systems.

**Figure 14–8** Surface drainage bedding



## (c) Landforming

Landforming refers to changing the land surface to ensure the orderly movement of surface water. Land smoothing and precision landforming are used in surface drainage to improve the effectiveness of the drainage system.

### (1) Land smoothing

Removing small irregularities on the land surface using special equipment is termed land smoothing. It does not require a grid survey and includes operations ordinarily classed as rough grading.

Land smoothing is an important practice for good surface drainage. It eliminates minor differences in field elevations and shallow depressions without changing the general contour of the ground surface appreciably. It results in better drainage, generally with fewer surface ditches, and enables farm equipment to be operated more efficiently. Smoothing also reduces ice crusting in winter.

Soils to be smoothed must have characteristics that allow small cuts. Except for isolated spots handled by prior rough grading, land smoothing operations seldom involve cuts and fills of more than 6 inches. High and low spots generally are visible to the eye without use of an engineer's level. However, sufficient spot elevations should be taken and adequate planning done to assure that water will readily move to the field ditches and laterals without ponding.

Land smoothing is accomplished best by special equipment, such as the landplane or leveler, which can work efficiently to tolerances of 0.1 foot or less. This degree of accuracy is necessary to remove irregularities from flat land. Rough grading for land smoothing can be done with farm tractors and scrapers or with a landplane. In making cuts, avoid removing all topsoil from any area. It is better to take thin layers from a larger area. Where fills from rough grading exceed 6 inches, make an allowance for settling. The allowance is related to the types of soil and soil conditions and may be given in the local technical guides. Final smoothing operations may be deferred until compaction or natural settlement of such areas has taken place.

### (2) Precision landforming

Precision landforming for drainage is reshaping the surface of the land to planned grades so that each row or plane is graded throughout its length to field ditches or other suitable outlets. The land is graded so that rows will carry surface runoff without overtopping. Row or plane grades may be varied within erosive limits to provide drainage with the least amount of grading. Local technical guides provide recommendations on precision landforming for drainage

**(i) Planning**—Topographic surveys are needed to plan the surface grading and the auxiliary drainage system. National Engineering Handbook, Part 623 (Section 15), Chapter 12, Land Leveling, provides information on surveys, design methods, construction, and maintenance. Local technical guides also provide information and applicable criteria.

**(ii) Construction**—Precision land smoothing is accomplished by earth-moving scrapers (fig. 14–9), land levelers, or landplanes (fig. 14–10). The length of most land smoothing equipment varies from 20 to 50 feet, with the longer length giving a more refined job. The large levelers or planes that have an overall span length of about 50 feet may require a crawler-type or 4-wheel drive tractor for power. Those that have a span length of 20 to 30 feet can be pulled with an ordinary wheel-type farm tractor. The smaller machines do a good job on any field, but require more trips over the field than the larger machine.

To facilitate smoothing operations, the ground surface should be chiseled or disked before smoothing and should be free of bulky vegetation and trash. Loosening facilitates the movement of the dirt by the leveler and mixes crop residue into the soil, thus preventing vegetation from collecting on the leveler blade. If the area is in sod, it should be tilled 3 to 6 months before smoothing operations begin, or it should be farmed in a cultivated crop for 1 year before smoothing.

The roughness of the field and the number of minor depressions determine the number of passes required to produce a smooth field. The land plane should make at least three passes; one pass along each diagonal and a final pass generally in the direction of cultivation.



The first year after smoothing, settlement may occur in large depressions that were filled. On relatively flat fields, this settlement can produce pockets that collect and hold water. The field should be observed the year after smoothing. If pockets have developed, at least three more passes should be made with special emphasis on the settled areas.

In areas where exposing the subsoil is necessary, you should remove and stockpile the topsoil, do the re-shaping, and then replace the topsoil.

**Figure 14-10** Landplane



**Figure 14-9** Earthmoving scraper with laser grade control



## 650.1412 Design of open drains

State drainage guides, standards, and specifications give criteria for side slopes, grades, spacing, and depth of drainage field ditches.

Mains and laterals are open ditches constructed to dispose of surface and subsurface drainage water collected primarily from surface field ditches and subsurface drains. They can also intercept ground water, help to control ground water levels, or provide for leaching of saline or sodic soils.

Factors affecting the size and shape of ditches are drainage runoff, hydraulic gradient, depth, bottom width, side slopes, roughness of the drain bed and banks, and limiting velocities. Local experience incorporated in the State drainage guide generally dictates the design factors for ditches.

### (a) Drainage runoff

Runoff is determined above and below the outlet of contributing ditches and streams, at points of change in the channel slope, at culverts and bridges, and at the outlet.

Runoff calculations generally begin at the upper end of the drain and proceed downstream. An empirical procedure, termed the 20-40 rule, should be used in computing the required capacity for a drain below a junction with a lateral. For large drainage areas, the application of the procedure may have considerable effect on the drain design. In small areas the change in required drain capacity may be so small that the procedure need not be applied. Experience in applying the 20-40 rule will guide the designer in its use. The rules for computing the required capacity for a drain are:

**Rule 1—Where the watershed area of one of the ditches is 40 to 50 percent of the total watershed area, the required capacity of the channel below the junction is determined by adding the required design capacity of each drain above the junction.** This is based upon the assumption that the flows from two watersheds of about the same size may

reach the junction at about the same time, and that therefore the drain capacity below the junction should be the sum of the two flows. This rule should be used in all cases for watershed areas of less than 300 acres.

**Rule 2—Where the watershed area of a lateral is less than 20 percent of the total watershed area, the design capacity of the drain below the junction is determined from the drainage curve for the total watershed area.**

**Rule 3—Where the watershed area of a lateral is from 20 to 40 percent of the total watershed area, the discharge is proportioned from the smaller discharge at 20 percent to the larger discharge at 40 percent.** In this range the discharges should be computed by both methods and the difference in cubic feet per second obtained. The design discharge for the channel below the junction should then be obtained by interpolation. This combination of rules 1 and 2 is illustrated in the following example.

### Example

A lateral drain draining 350 acres joins a drain draining 650 acres, making a total drainage area below the junction of 1,000 acres. One of the watersheds is 35 percent of the total watershed. Using rule 3, assume that the curve developed from  $Q = 45 M^{0.83}$  applies. Find the discharges using information in figure 14-4 and table 14-1.

| Rule | Watershed area (acres) | Runoff $Q = 45 M^{0.83}$ (ft <sup>3</sup> /s) |
|------|------------------------|---|
| 1    | 350                    | 27  |
|      | 650                    | 45  |
|      |                        | <b>72 (total)</b>                             |
| 2    | 1,000                  | 65  |
|      |                        | <b>7 (difference)</b>                         |

The difference between 20 and 40 percent is 20 percent. Thirty-five percent is 15/20 (0.75) of the difference between 20 and 40 percent. Then, 0.75 times 7 ft<sup>3</sup>/s equals 5.2 ft<sup>3</sup>/s (use 5 ft<sup>3</sup>/s). Add 5 ft<sup>3</sup>/s to 65 ft<sup>3</sup>/s to arrive at 70 ft<sup>3</sup>/s for the capacity of the drain below the junction. Note that this value is an interpolation between the results of rule 1 and rule 2.

Design flows are required at other points along the drain in addition to those for ditches below junctions. These points will be discussed later in this chapter.

### (b) Drain alignment

The natural topography and aesthetics should be considered in determining drain alignment. Where it is necessary to change direction of the drain or field ditch, a simple curve should be used (see NEH, Part 650, Chapter 1, Engineering Surveys). Curves that have a radius greater than 600 feet are desirable, but sharper curves can be used if needed to follow old ditches or swales, to decrease the waste area caused by the use of long radii curves, or to conform to ownership boundaries. Where the drain flows are small and of low velocity, gentle curvature is not as important.

### (c) Hydraulic gradient

The hydraulic gradient is the slope of the hydraulic gradeline (water surface) and is important in determining flow velocity. Proper location of the gradeline is more important as drain flows become greater. The profile of the channel should be plotted showing the location and elevation of control points. The control points help to select the maximum elevation of the hydraulic gradeline desired for the drain. They may include, but are not limited to, the following:

- Natural ground elevations along the route of the proposed drain.
- Location, size, and elevation of critical low areas to be drained. These are obtained from the topographic data.
- Hydraulic gradeline for side ditches or laterals established from the critical areas to the design drain. Plot the elevation where the side drain hydraulic gradeline meets the design drain as a control point.
- Where laterals or natural streams enter the design drain, use the same procedure as that for hydraulic gradeline for side ditches.
- Bridges across drainage ditches should not reduce the area of the design cross section. Where feasible to do so, the hydraulic gradeline should be placed 1 foot below the stringers of the bridge. The allowable head loss on culverts should be kept low. On agricultural drainage the allowable head

loss generally should not exceed 0.5 foot.

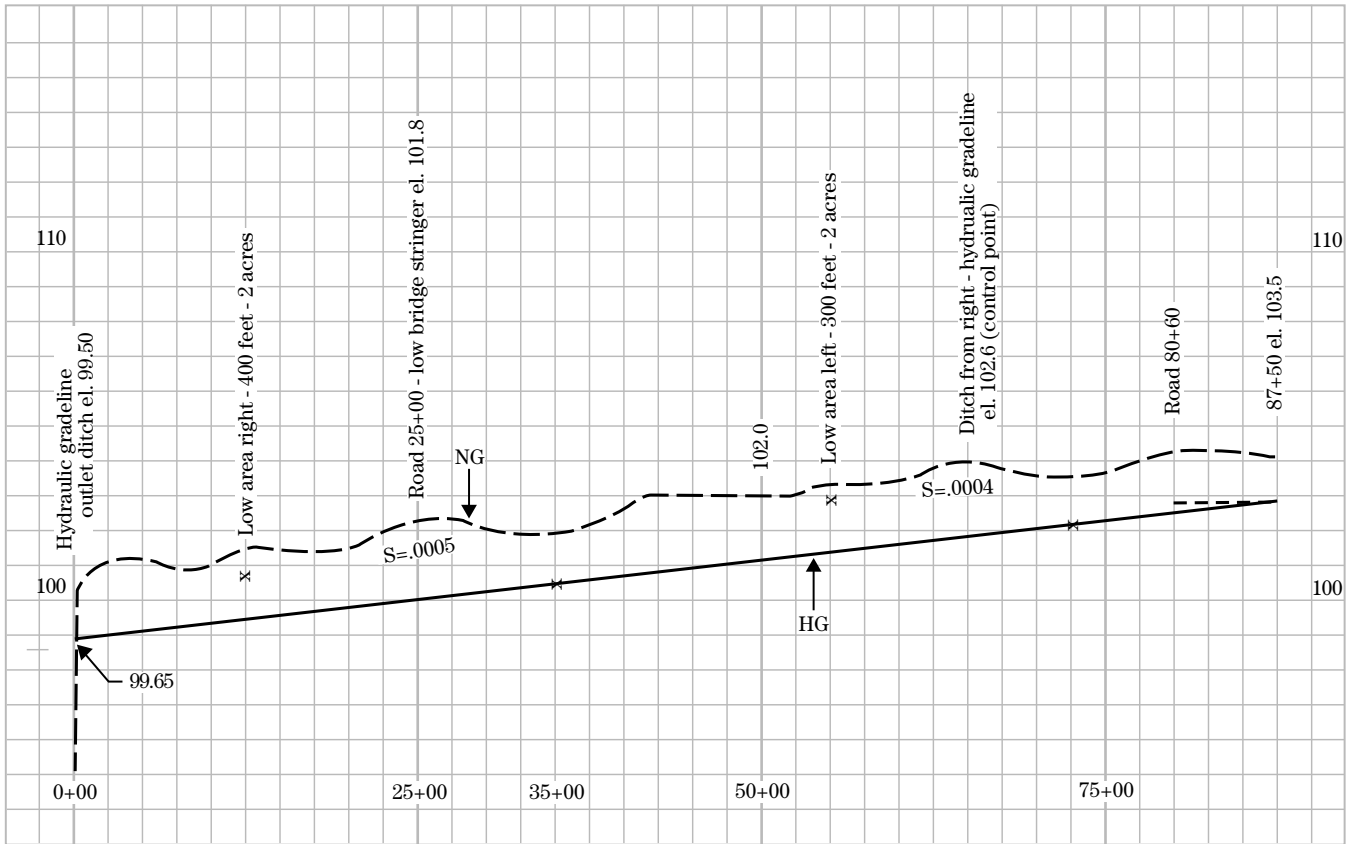
- Elevations of buildings or other property within the area to be protected from overflow.
- If the drain being designed is to outlet into an existing drain or natural stream, the elevation of the water in the outlet drain or stream against which the designed drain must discharge should be used as a control point. The water surface elevation in the outlet ditch may be determined from recorded data, historic observation, or high water marks. Another method of obtaining this elevation is to determine the depth of flow in the outlet ditch by applying the same flow design basis as that used for the proposed ditch. For small outlet ditches in rather flat topography, the water elevation may be estimated at the bankfull stage.

Control points should be connected with a line on the profile. The hydraulic gradeline is drawn through or below the control points. The grades should be as long as possible and should be broken only where necessary to stay close to the control points (fig. 14–11).

If the hydraulic gradeline has been well established, it will not be altered except at structures that have head losses. At these control points, the head loss will be shown upstream from the structure as a backwater curve. This will change the hydraulic gradient, although generally for only a short distance.

If the channel is in an area of flat topography and the hydraulic gradeline is located near field elevation, the hydraulic gradeline may need to be broken at culverts in amounts equal to the required head, otherwise, the backwater curve above the culvert may cause problems. The problems are compounded if several culverts are within a relatively short channel.

**Figure 14-11** Establishing hydraulic gradeline



**Note:** For this design the hydraulic gradient (HG) must be 0.5 feet below natural ground (NG). The control points selected were 101.4 @ sta 35+00 and 102.90 @ sta 72+50.

## (d) Design methods

**Design by reaches**—Drain design may be done by reaches (specific length of ditch). One method is to design the ditch for the required capacity of the lower end of the reach and use that section throughout the reach. If this method is used, the upper end of the reach will be oversized. Reaches should be selected so that oversizing is held to practical limits. To reflect the flow conditions as nearly as possible, the selection of the length of reach is important. To determine the beginning and the end of reaches, you can use one of the following:

- Tributary junctions where the required drain capacity changes.
- A break in grade of the water surface profile.
- Divided reach—An increasing drainage area may require that an otherwise long reach be divided into shorter reaches. A knowledge of where water enters the drain, as well as the amount, helps to determine how the reach should be divided.
- Bridges or culverts can be used to begin or end a reach.

After the hydraulic gradeline has been established, determine the drainage area and the required drain capacity at the upper and lower end of each reach. At this time obtain the drainage area and the required capacity for any planned structure (culvert, side inlet, grade control). This information is used in designing the structure.

**Point method**—Drain design by the point method is sometimes preferred. In this method the required depth of the drain is determined at the control points for the discharges at those points. This assumes that the runoff throughout the reach enters uniformly along the reach. In reality, the depth at the beginning and end of a reach differ. The depths are established at points below the hydraulic gradeline, and the bottom of the drain is drawn between the points. The slope of the drain bottom normally is not parallel to the hydraulic gradeline. At points where concentrated flow enters, a change in depth or width, or both, may be required. A transition may also be required at these points.

### (1) Drain depth

Factors that must be considered in establishing the drain depth are:

- Depth to provide the capacity for removing the surface runoff plus freeboard.
- Depth to provide outlet for subsurface drainage.
- Depth to clear bridges.
- Depth to allow for sufficient capacity after subsidence in organic soils.
- Depth to trap sediment below the elevation of a design flow line.

**(i) Surface discharge**—Sufficient depth must be provided for surface runoff to flow freely into the ditch. Where the hydraulic gradeline has been established, as shown in figure 14-11, the depth of the ditch is measured down from the gradeline. Where the ditch bottom grade is established first, the depth is measured upward to locate the water surface. Using this last method, the water surface elevation obtained must be checked in relation to control points. The depth of each reach should be determined to meet the needs of the specific area involved.

**(ii) Subsurface discharge**—Ditches used to serve as outlets for subsurface drains should be deep enough to provide free outfall from the underdrain with at least 1 foot of clearance between the invert of the drain and the normal low water flow in the ditch. Ditches designed to intercept subsurface flows or to serve as an outlet for subsurface drainage should be deep enough to serve these conditions. The required depth sometimes results in the ditch capacity being in excess of the design flow requirements for surface runoff, and the actual hydraulic gradeline may be substantially lower. This often occurs at the upper end of small drainage systems.

### (2) Grade of ditch bottom

If uniform flow in the ditch is assumed, the ditch bottom grade will have the same slope as the hydraulic gradeline. The required depth of the ditch is determined and measured at points below the hydraulic gradeline. These points are then connected to find the bottom grade of the ditch. This method of locating the ditch bottom is generally satisfactory in designing a new ditch. If this method is used, you may prefer to adjust the bottom grade to eliminate the need for transitions.

In reconstruction of existing ditches, the elevation of the existing ditch bottom, the bridge footings, and the soil strata must be considered as control points in establishing the bottom of the designed ditch. At

times, it may be more convenient to locate the bottom of the ditch from these control points and measure the design depth up from the bottom to locate the hydraulic gradeline (water surface). Cross sections must be used in deciding upon the hydraulic grade or the ditch bottom. Ditch bottom grades that will be erosive during normal flows are to be avoided.

### (3) Ditch side slopes

The side slopes of ditches are determined primarily by the stability of the material through which the ditch is dug and by the methods of maintenance to be practiced. Recommended sideslopes may be found in many local drainage guides. Maintenance requirements may necessitate modification. The steepest side slopes recommended for ordinary conditions for mains or laterals are as follows:

| Material   | Side slope<br>(Horizontal to<br>vertical ratio) |
|--|---|
| Solid rock, cut section                            | 0.25:1  |
| Loose rock or cemented gravel, cut section         | 0.75:1  |
| Heavy clay, cut section <sup>1/</sup>              | 1:1   |
| Heavy clay, fill section <sup>1/</sup>             | 2:1   |
| Sand or silt with clay binder, cut or fill section | 1.5:1   |
| Loam   | 2:1   |
| Peat, muck, and sand <sup>2/</sup>                 | 1:1   |

<sup>1/</sup> Heavy clays in CH soils often experience sliding problems caused by the structure of the clays. The recommended side slope for these soils is no steeper than 4:1.

<sup>2/</sup> Silts and sands that have a high water table in the side slopes will slough due to hydrostatic pressure gradient. The recommended side slope for these saturated conditions is no steeper than 3.5:1.

Local information may indicate that steeper side slopes can be used in certain soils; however, flatter side slopes may be desirable for more satisfactory and economical maintenance. Ditch side slopes that can be used with various maintenance methods are given in table 14-2.

### (4) Velocity in ditches

The velocity in a ditch is ideal if neither scouring nor sedimentation occur. Because flows in most ditches are intermittent, the velocity will fluctuate. Ditches are generally designed for the maximum design flow and the allowable average velocity in the ditch section. Table 14-3 give the recommended limiting velocities at design flow depth for various soils and material. If the velocity is above these limits, scouring and erosion

**Table 14-3** Permissible bare earth velocities

| Soil texture                                   | Maximum velocity<br>ft/s |
|--|--------------------------|
| Sand and sandy loam (noncolloidal)             | 2.5                      |
| Silt loam (also high lime clay)                | 3.0                      |
| Sandy clay loam                                | 3.5                      |
| Clay loam                                      | 4.0                      |
| Stiff clay, fine gravel, graded loam to gravel | 5.0                      |
| Graded silt to cobbles (colloidal)             | 5.5                      |
| Shale, hardpan, and coarse gravel              | 6.0                      |

**Table 14-2** Ditch side slopes recommended for maintenance

| Type of maintenance | Recommended steepest<br>side slopes | Remarks   |
|---------------------|-------------------------------------|---|
| Mowing and grazing* | 3:1                                 | Flatter slopes desirable  |
| Dragline or backhoe | 0.5:1                               | Generally used in ditches (more than 4 feet deep) that have steep side slopes |
| Blade equipment     | 3:1                                 | Flatter slopes desirable  |
| Chemicals           | Any                                 | Use caution near crops and open water. Follow manufacturer's recommendations  |

\* Hydraulically operated booms that have a 10- to 14-foot reach may be used to mow side slopes as steep as 1:1.

may take place. Because raw, newly dug ditches may have a lower roughness coefficient (Manning's  $n$ ) than they will have after some aging of the ditch takes place, they may have higher than design velocities. Where vegetation on the ditch side slopes is slow in developing, the limiting velocities may need to be reduced. Minimum design velocities should not be less than 1.4 feet per second to prevent sedimentation. Short field ditches may be used to capture sediment for a water quality benefit. In this case, design velocity should be less than 1.4 foot per second with provision to return sediment to the field.

### (5) Determination of ditch velocity

Manning's equation is used in determining the average velocity in a ditch section.

$$V = \frac{1.486}{n} R^{0.667} S^{0.5}$$

where:

$V$  = velocity (ft/s)

$n$  = roughness coefficient

$R$  = hydraulic radius (ft) =  $A/P$

$S$  = slope (ft/ft)

$A$  = cross-sectional area below hydraulic gradeline (ft<sup>2</sup>)

$P$  = wetted perimeter (ft)

For information on computation, refer to EFH Chapter 3, Hydraulics, or use any appropriate computational procedure.

### (6) Value of roughness coefficient $n$

The value of  $n$  is a factor in Manning's formula for computing velocity. It indicates not only the roughness of the sides and bottom of the channel, but also other types of irregularities of the channel, such as alignment and vegetation. The value of  $n$  is used to indicate the net effect of all factors causing retardation of flow. The selection requires judgement in evaluating the material in which the channel is constructed, the irregularity of surfaces of the ditch sides and bottom, the variations in the shape and size of cross sections, and the obstructions, vegetation, and meandering of the ditch.

The National Engineering Handbook, section 16, relates  $n$  values to the hydraulic radius and indicates that these values decrease when the hydraulic radius

increases. Table 14-4 gives the recommended values of  $n$ . They are the values that may be expected after aging. The  $n$  value that occurs immediately after construction will be lower than those given in the table. Unless special site studies are available to determine the value of  $n$ , the table 14-4 values shall be used.

### (7) Ditch bottom width

The machinery used for construction of the ditch should be considered in the selection of ditch bottom width. A bulldozer or blade equipment is used to construct V-shaped ditches. Flat bottom ditches frequently are designed if scrapers, hydraulic hoes, or draglines are to be used to construct the ditch. Depth of ditch and soil conditions affect the type of equipment used. Specified minimum bottom widths are often based on the available equipment.

### (8) Relationship between depth and bottom width

The most economical ditch cross-section approaches that of a semicircle. A deep, narrow ditch generally carries more water than a wide, shallow ditch of the same cross-sectional area. An excessively wide, shallow ditch tends to develop sand or silt bars, which cause ditch meandering and bank cutting, and a fairly deep, narrow ditch tends to increase velocities and reduce siltation and meandering. Because the cross-section selected is a matter of judgment, all factors involved should be considered. Ditches shall be designed to be stable. In some cases economy and hydraulic efficiency must be sacrificed in the interest of ditch stability and maintenance.

**Table 14-4** Value of Manning's  $n$  for drainage ditch design

| Hydraulic radius | $n$           |
|------------------|---------------|
| Less than 2.5    | 0.040 - 0.045 |
| 2.5 to 4.0       | 0.035 - 0.040 |
| 4.0 to 5.0       | 0.030 - 0.035 |
| More than 5.0    | 0.025 - 0.030 |

**(9) Calculation of ditch capacity**

The volume ( $Q$ ) of water passing a ditch cross section is calculated in cubic feet per second ( $\text{ft}^3/\text{s}$ ) and is the product of the flow area cross section ( $A$ ) in square feet ( $\text{ft}^2$ ) and the average velocity in the cross section ( $V$ ) expressed in feet per second ( $\text{ft}/\text{s}$ ). The formula is:

$$Q = AV$$

Various curves, tables, and computer software, all based on Manning's formula for velocity, have been prepared to determine ditch capacities (appendix 14A).

**(10) Ditch berms**

Berms should be designed to:

- provide roadways for maintenance equipment;
- provide work areas;
- facilitate spoil-bank spreading;
- prevent excavated material from washing back into ditches; and
- prevent sloughing of ditchbanks caused by placing heavy loads too near the edge of the ditch.

The recommended minimum berm widths are as follows:

| Ditch depth<br>ft | Minimum berm width<br>ft |
|-------------------|--------------------------|
| 2 – 6             | 8                        |
| 6 – 8             | 10                       |
| > 8               | 15                       |

**(11) Spoil banks**

Spoil-bank leveling or shaping is a common and desirable practice. The degree of leveling, the placing of the spoil, and other practices related to the spoil generally are determined locally and are specified in local drainage guides or State standards and specifications.

**(12) Bridges and culverts**

Design criteria for structures required for drainage ditches, or where irrigation canals cross drainage ditches, are specified by the authority responsible for the structure. The capacity requirement for the structure may be for flood flows that are much more intense than the drainage requirement. On some township, private, and field roads the only requirement may be that the structure carry drainage flow. The following information is limited to this type of structure.

The structure must meet two requirements:

- They must be of sufficient size and located so as to pass the design flow within the allowable head loss.
  - They must have adequate strength, size, and durability to meet the requirements of traffic.
- The following formula can be used to compute the minimum culvert length without headwalls.

$$L = W + 2SH$$

where:

$L$  = minimum culvert length

$W$  = top width of fill over culvert, not less than levee top width

$S$  = side slopes of fill over culvert

$H$  = height of fill measured from culvert invert

Existing structures should be measured to determine their capacity. An existing structure may be considered adequate if it will pass the design drainage flow with a head that does not cause overbank flow above the structure. As a safety factor, new culvert installations generally are designed for 25 percent more capacity than the ditch design. A new bridge should be designed to span the ditch, have the bottom of the stringers placed at least 1 foot above the hydraulic gradeline, and preferably have no piers placed in the center of the ditch.

The hydraulic gradeline at structures does not need to be broken as long as the head loss required to pass the design flow does not cause overbank flooding above the structure. The hydraulic gradeline should be adjusted if such flooding will occur. The gradeline may be broken and dropped down at the structure at an amount equal to the head loss.

Head loss is negligible through bridges where the channel cross section is not restricted. Head loss through culverts ordinarily should not exceed 0.5 foot. It can be reduced by increasing the size of the structure.

**(13) Culvert flow**

Culverts are used for several types of flow. Detailed knowledge of hydraulics is necessary under some situations for the design of culverts. The following situations commonly occur where culverts are used:

- Culverts flowing full with both ends submerged.
- Culverts flowing full with unsubmerged or free discharge.



- Culvert flow limited by culvert entrance conditions.

See EFH Chapter 3, Hydraulics, for design procedure. See also appendix 14B.

#### (14) Ditch junctions

The bottom grades of ditches having about the same depth and capacity should be designed to meet at or near the same elevation. The bottom of a shallow, small capacity ditch may be designed to meet a larger ditch at or near the normal or low flow elevation of the larger ditch.

A transition is designed where a shallow ditch enters a much deeper ditch. Before beginning a transition, the grade of the shallow ditch generally is designed 10 to 100 feet upstream on a zero grade at the elevation of the deeper ditch. The transition should be on a non-erosive grade not to exceed 1 percent.

Where the difference in the elevation of the ditch gradelines is considerable and transition grades seem impractical, a structure should be used to control the drop from the shallow ditch to the deeper ditch. See EFH Chapter 6, Structures, for additional information.

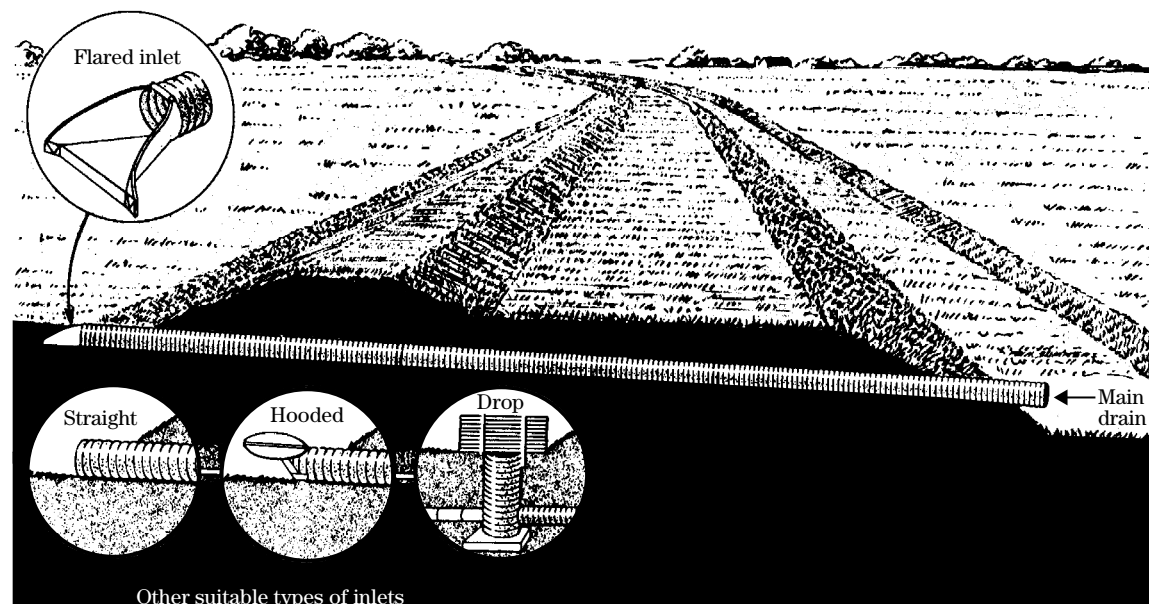
#### (15) Surface water inlets to ditches

All drainage into mains and laterals should be through planned inlets, rather than at random, which can cause rills or severe bank erosion. This may be accomplished by installing chutes, drop spillways, pipe drop inlet spillways, culverts, or other suitable structures (fig. 14-12). For additional information on inlets, see EFH, Chapter 6, Structures.

#### (16) Swinging watergates, cattle guards, and ramps

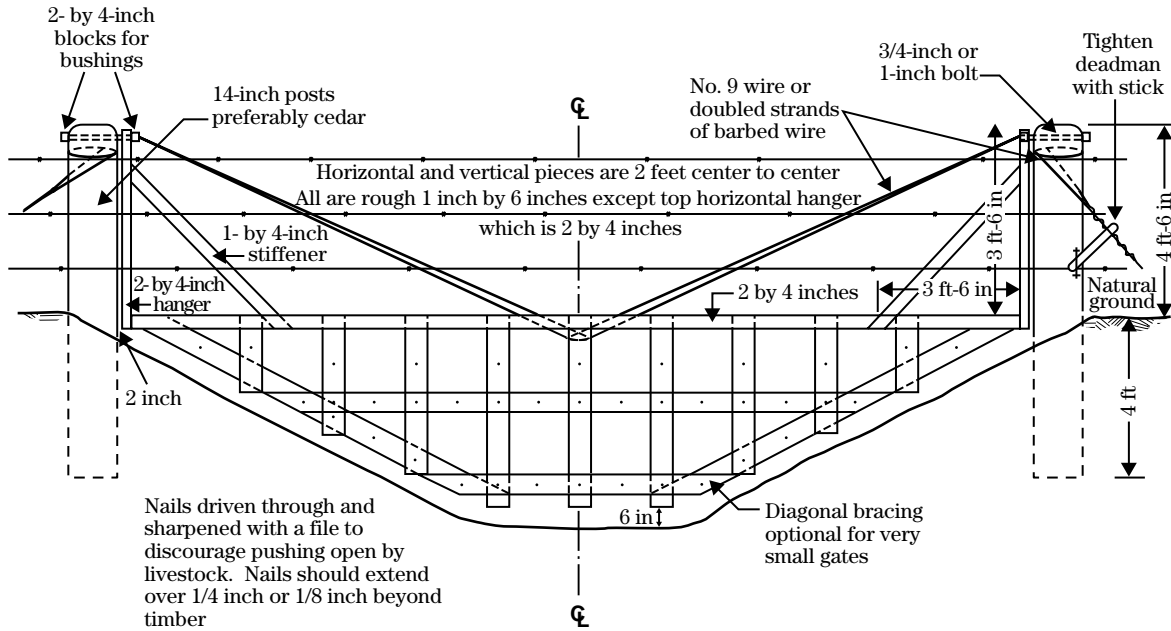
Where applicable, watergates, cattle guards, and ramps should be used on open ditches to manage livestock and to protect the ditches. See figure 14-13a for a typical watergate plan and figure 14-13b for photograph of similar watergate installation for livestock crossing.

**Figure 14-12** Surface water inlets



**Figure 14-13** Watergate

**a Watergate plan**



**b Livestock crossing using watergates**



**(17) Ditch design problem****Example—Open ditch design****Given:**

Drainage area is 1,450 acres (fig. 14–15)

Apply  $Q = 22.5 M^{0.83}$  curve on 200 acres

Apply  $Q = 45 M^{0.83}$  curve on 1,250 acres

Profile of ditch from figure 14–14

Side slopes (ss) = 2:1

Value of  $n = .045$

Minimum bottom width (b) = 4.0 feet

M = area in square miles

**Required:**

Design of ditch for surface water removal.

**Solution:**

1. Locate control points and hydraulic gradeline as shown in figure 14–14.

2. Draw subdivides for reaches and other design points (fig. 14–15) and determine their drainage areas.
3. Begin preparing figure 14–16, and determine the discharge for design points using the equation. The area above station 87+50 is 0.31 square mile (200 acres), applicable to the curve developed from  $Q = 22.5 M^{0.83}$ . This is adjusted to 0.134 square mile (86 acres) developed from  $Q = 45 M^{0.83}$ . This is done so that the upper area can be added to the areas below this point. The "20-40" rules 1 and 2 were applied as necessary.
4. Prepare hydraulic computations using figure 14–16. Show the drainage area, discharge in cubic feet per second, side slopes,  $n$  values, and hydraulic gradient at each design point.

**Figure 14–14** Profile ditch with hydraulic gradient

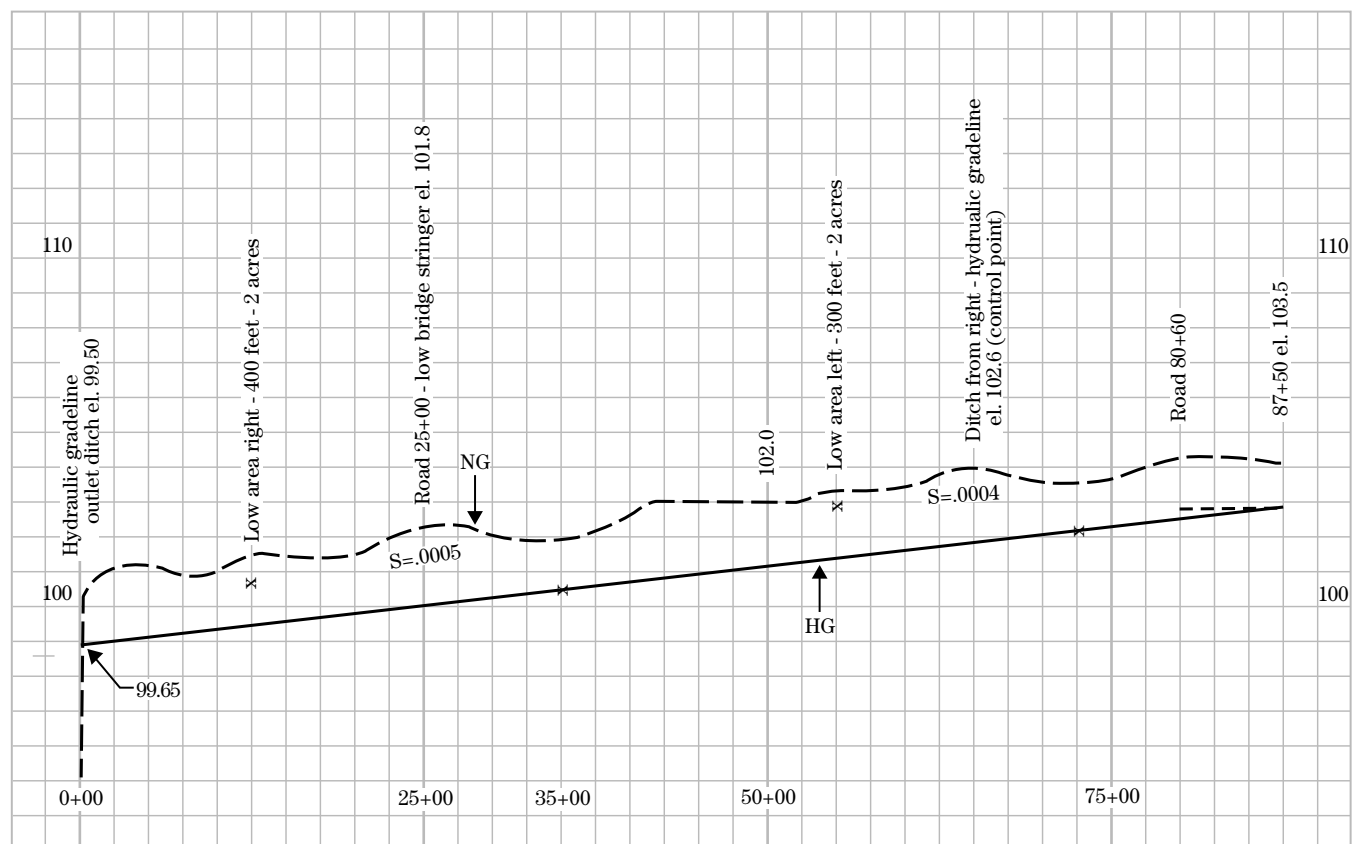
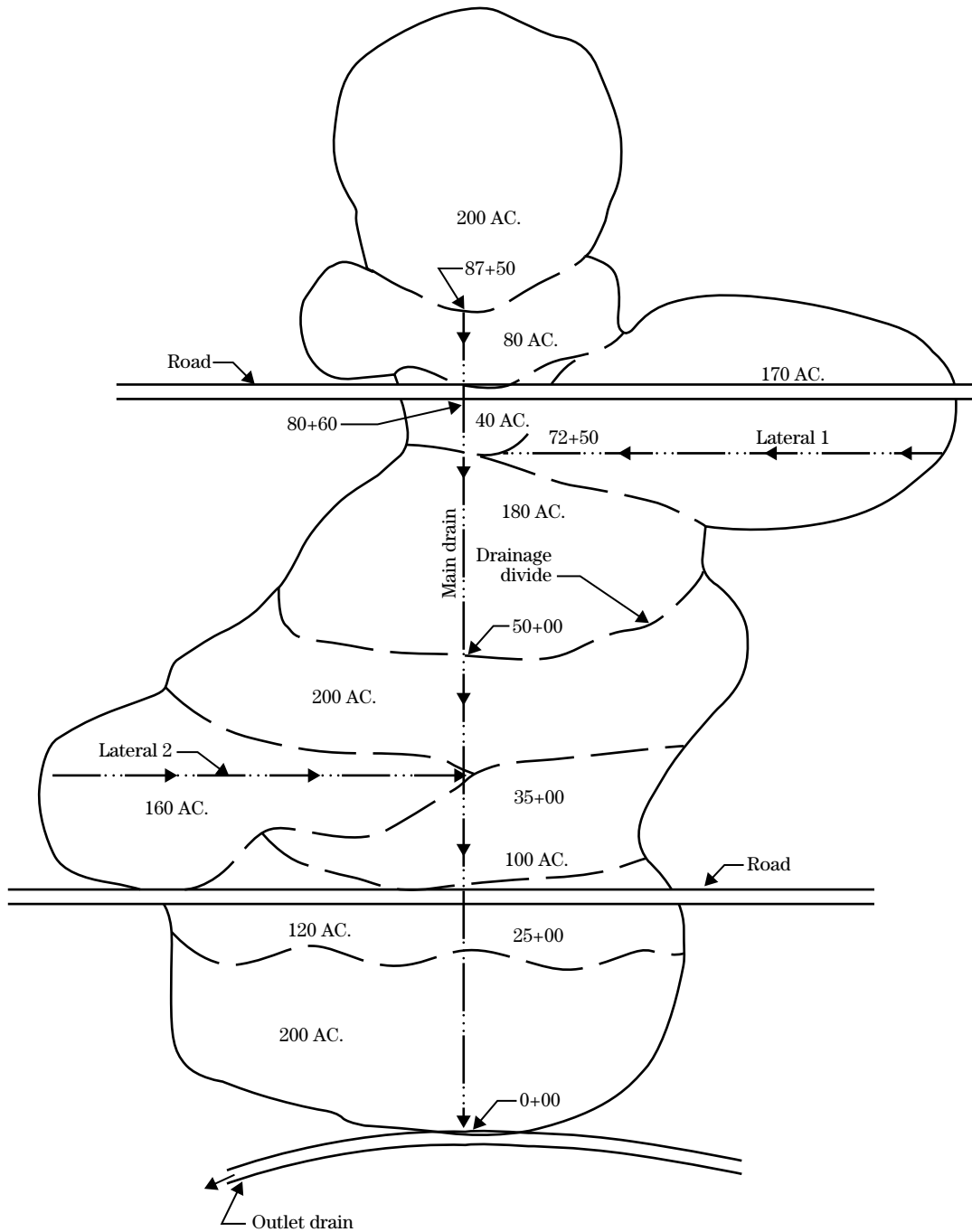


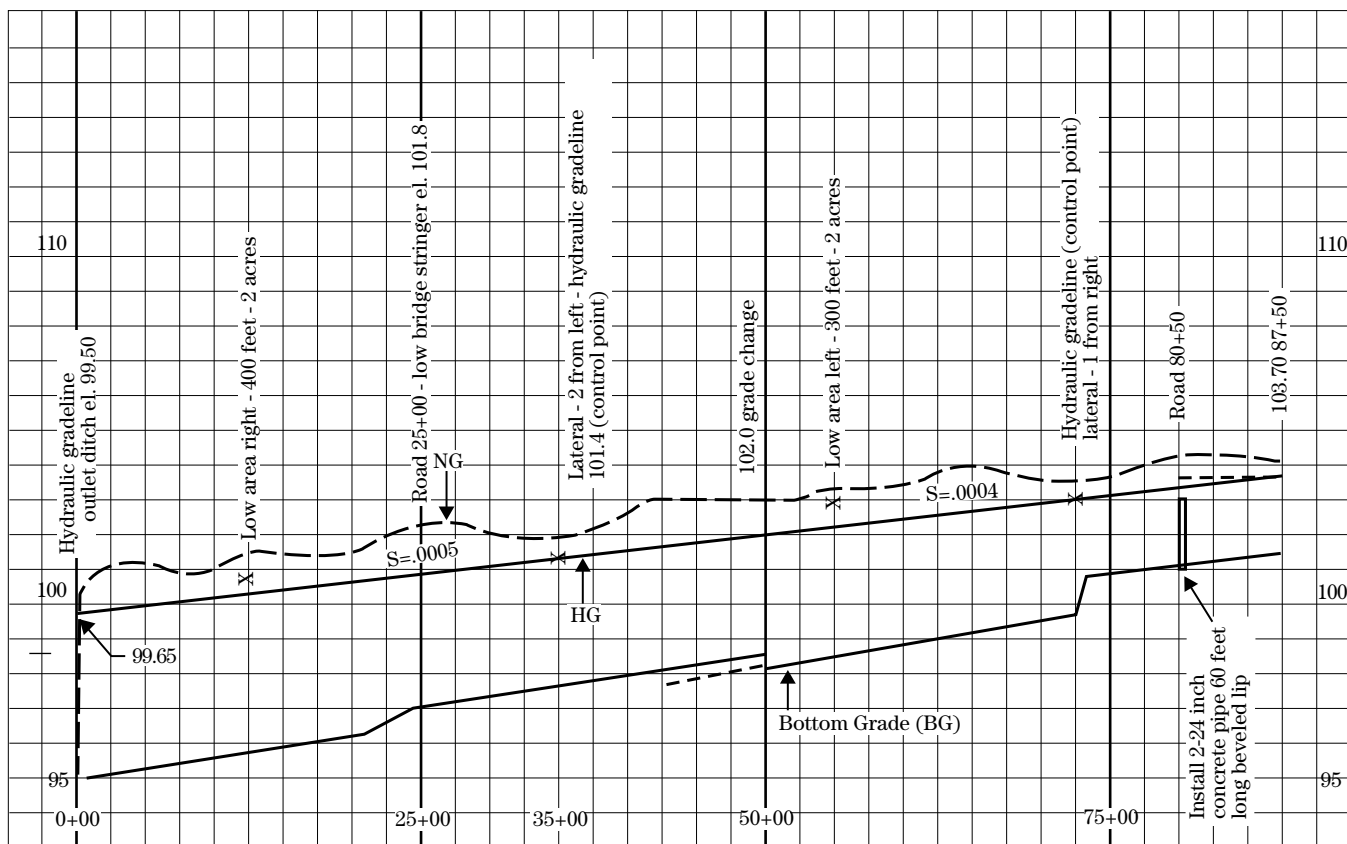
Figure 14-15 Watershed sketch





5. Begin with a trapezoidal cross section, using a 4-foot bottom width. Determine the depth and velocity for each design point. This may be done by using computer programs, appropriate hydraulic tables, curves with varying bottom widths, or hydraulic programs for the programmable calculators. Appendix 14A was used for this example problem. The bottom width, depth, and velocity should conform with the previously specified requirements for drainage ditch design. If they do not conform, assume a different bottom width or channel cross-section shape and recalculate.
6. To establish the bottom of the ditch, measure the calculated depths downward from the hydraulic gradeline. Figure 14-17 shows drops at stations 25+00 and 75+50 and a rise at station 50+00. This rise is eliminated by continuing the upstream cross section until it blends with the downstream cross section. The bottom is satisfactory for design regardless of the drops; however, the drops should be eliminated by varying the bottom width. Most machine work is not so accurately done that small drops will be detrimental to the ditch. For larger drops, the design should be changed or a transition section should be installed at the drops.
7. Bridge at station 25+00—Field information on this existing bridge indicates that the area of flow of the new ditch will not be reduced an appreciable amount and that no head loss will occur at the bridge. Therefore, the hydraulic gradient will not be changed at that point.
8. A new crossing is to be established at station 80+50 where  $Q = 18 \text{ ft}^3/\text{s}$ . Assume that two 60-foot long, 24-inch concrete pipes that have a beveled lip will be installed. Determine the head loss.

**Figure 14-17** Design profile



**Solution** (use appendix 14B at the back of this chapter): The tailwater depth is 26 inches, and the pipe will have a submerged outlet. Table C-1, appendix 14B, gives a value of  $C$  as 0.75 for a 24-inch concrete pipe, beveled lip entrance. A half of  $18 \text{ ft}^3/\text{s}$  is  $9 \text{ ft}^3/\text{s}$  for each 24-inch pipe. Determine  $Q/C$ :

$$\frac{Q}{C} = \frac{9.00}{0.75} = 12$$

Table A shows that this requires a head of 0.23 foot. The velocity for the pipe is:

$$V = \frac{Q}{A} = \frac{9 \text{ ft}^3/\text{s}}{3.14 \text{ ft}^2} = 2.86 \text{ ft/s}$$

Table F shows that the upper end of the pipe should be placed 0.14 feet below the water surface or hydraulic gradeline upstream of the culvert.

Referring to figure 14-17, the downstream end of the pipe will be placed at station 80+20, and the water surface elevation will be 103.21. The upper end of the pipe will be at station 80+50. The water surface elevation at the upper end of the pipe will be 103.24 plus 0.23, or 103.47. The water surface from this point will curve upstream and intersect the original water surface several hundred feet upstream. It is evident from the profile that this change in water surface will cause no damage upstream.

The main advantage in using this method of design is that once the hydraulic gradeline is set, various structure sizes may be selected without changing the tailwater elevation and involving only the backwater curve.

## 650.1413 Construction

### (a) Open drain layout

The amount of staking required depends upon the topography, the size of ditch, the type of equipment used, and the experience of the contractor or cooper-ator. A centerline stake, slope stakes, and offset refer-ence stakes may be set at every station. Sometimes the centerline cut or fill is marked on the centerline stake. In many cases staking is not required at every station, but a sufficient number of stakes should be set to obtain the intended result. The method used should conform to state requirements.

### (b) Structures

All culverts and bridges should be installed or rehabili-tated immediately after the site has been excavated. The structures should be installed as planned. The bottom of ditches should be rounded to conform to the shape of the culverts. Where multiple pipe culverts are used, the space between the barrels should be at least half the diameter of the culvert. All backfill should be carefully and firmly tamped.

### (c) Watergates

Swinging watergates should be constructed of light, durable material. They should be hung so that they do not swing through too great an arc before the bottom of the gate rises to the elevation of the water surface. To prevent the gate from becoming grass bound, a clearance of about 6 inches between the gate and the bottom and sides of the ditch is needed. See figure 14-13 for a typical plan of a swinging watergate.

### (d) Surface water inlets

Pipe overfall structures generally discharge into areas recessed in the banks of the outlet ditch. This is espe-cially necessary if the outlet is a flowing stream. If they are installed in this manner, they will not be damaged by the movement of water, ice, and debris in

the outlet; and the flow in the outlet will not be retarded. The installation should be completed by adequately tamping the soil around the pipe. To prevent a failure by washout, the fill over the pipe should be brought up high enough and along the pipe far enough to force any possible overflow water to the sides. This is generally referred to as an island method of installation.

The installation of inlet structures on fills should be avoided. The pipe needs to be well bedded—the bottom part of the excavation should conform closely to the shape of the pipe. This fine grading should extend up the sides of the pipe to a point where the backfill can be easily reached with a hand or mechanical tamper. All joints should be watertight.

### (e) Berms, spoil banks, and seeding

The use of the practices of leaving berms on ditches, leveling of spoil, and seeding ditch slopes, berms, and leveled areas varies with the locality. The spoil should be shaped to facilitate maintenance. Where no berm is left and spoil is shaped into a road, the height of the road should be limited to that which will not cause sloughing of the ditchbanks. In all cases, the spoil should be shaped so that the minimum amount of water flows directly back into the ditch. Consideration should be given to controlling erosion of the spoil. State standards for the above items should be used (figs. 14–18 and 14–19).

**Figure 14–18** Main drain with spoil banks spread





## (f) Safety

Contractors are responsible for construction site safety. Federal regulations covering safety for all types of construction are published in the Safety and Health Regulations for Construction, Department of Labor, Occupational Safety and Health Administration. Many state, municipality, and other local agencies have established codes and safety practices regarding construction. These regulations apply to all types of construction including alteration and repair work.

Personnel and contractors associated with drainage installation should be thoroughly familiar with the safety requirements and follow the required practices, procedures, and standards. Utility companies must be contacted before any excavation activity. See section 650.1427(d), Utilities, and NEM part 503.

**Figure 14-19** Seeding newly constructed drain



---

## 650.1414 Maintenance

A definite maintenance program should be agreed upon when the drainage system is planned because the maintenance methods to be used can materially affect the design. A good maintenance plan should include the practices to be used as well as the approximate time of the year when specific practices are applicable.

Unless the growth of vegetation and silting are controlled by regular maintenance, they may quickly decrease the effectiveness of the drain. The capacity of an open drain can be reduced by as much as 50 percent in 1 year by sediment and a heavy growth of weeds or brush.

### (a) Mowing

Mowing to control vegetation on spoil banks, berms, and drains is economical and effective if the side slopes are not too steep. For safety, side slopes on which farm tractors are to be operated should be made 3:1 or flatter—4:1 slopes are preferred. Side slopes as steep as 1:1 can be mowed using mowers mounted on hydraulically operated booms (fig. 14–20). Timing and frequency of mowing should consider wildlife values, weed control, and considerations for controlling other vegetative conditions, such as to avoid snow entrapment along traffic lanes and volunteer woody growth.

---

**Figure 14–20** Maintenance by mowing



## (b) Burning

Burning in winter or early spring, when the vegetation is dry and the ground is wet, is sometimes used to control undesirable vegetation in drainage ditches. Bridges, plastic pipe outlets, fences, and other property must be protected from burning. Any burning activity should be in compliance with State and local laws. Impacts on air quality should be a major consideration.

## (c) Chemicals

Chemicals to control undesirable vegetative growth have produced some excellent results and are used by land users and drainage enterprises. Caution should be used in their application to prevent impact to wildlife, crop damage, and water pollution from the drifting

chemicals. Broadleaf crops and some truck crops are particularly susceptible to damage. Information on appropriate chemicals is available from local dealers or current USDA publications. Major chemical companies have prepared considerable information relative to usage of specific products.

For guidance in the use of chemicals on common ditchbank weeds, refer to the manufacturer's recommendations or local technical guides. Some states have prepared technical guides and herbicide manuals in cooperation with other agencies. The most up-to-date information available, including data on new herbicides, should be followed. State laws governing use of herbicides must be followed. All chemicals shall be used according to the labeled instructions. Figure 14–21 shows precision application of chemicals for side slope weed control above the waterline of a drain.

**Figure 14–21** Application of chemicals for side slope weed control



### (d) Biological

Because of environmental dangers associated with the use of herbicides or burning, the search for other solutions is ongoing. In open channels with permanent water, fish known to consume large quantities of vegetation, such as the Tilapia, are used with good results. This application is very limited; however, a greater awareness of this alternative and a continuing search for acceptable methods are needed.

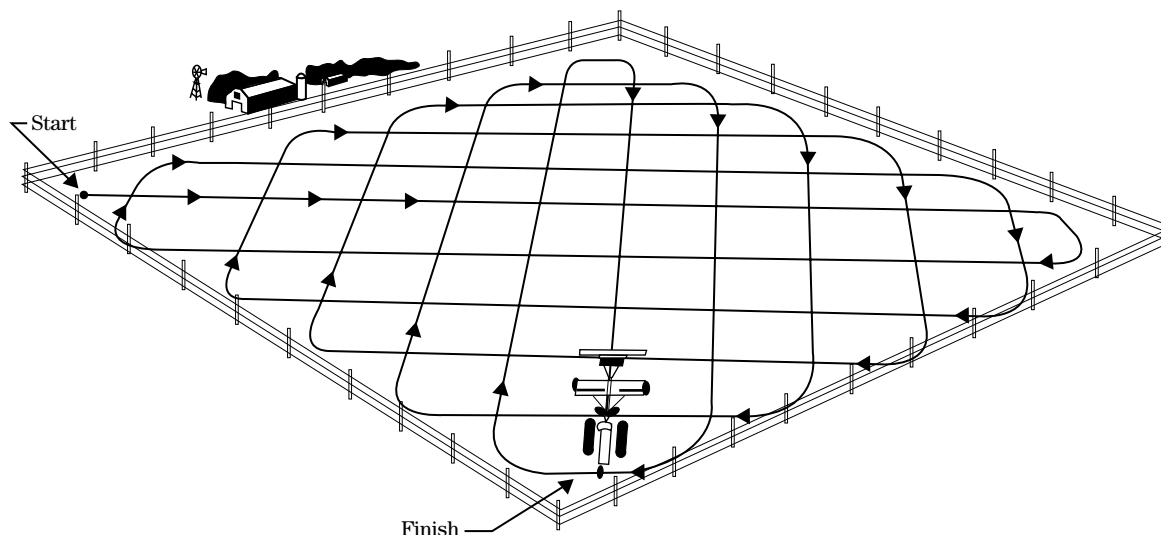
### (e) Maintenance of landforming

Land preparation practices require year-to-year maintenance to retain their efficiency. Once the field is properly prepared to achieve good surface drainage,

the ordinary crop cycle involving tillage, planting, cultivating, and harvesting, along with the wind and water action during the year, can disturb the surface enough to impound water and cause crop damage. Because cropping cycle irregularities, such as implement scars, need to be erased before each crop is planted, a leveler or plane should be operated over the area each year. This operation also will take care of settlement in the fill areas and provide a base for a good seedbed.

The diagonal method of maintenance is shown in figure 14-22. Using this method, farm operators can cover most fields with two passes of the leveler in the minimum amount of time. They report that this method reduces the maintenance time by about 25 percent. Figure 14-23 shows a type of land smoothing equipment.

**Figure 14-22** Land leveler operation for land smoothing maintenance



**Figure 14-23** Land smoothing equipment





---

**650.1420 General**

Subsurface drainage removes or controls free water from the soil surface and below the surface of the ground. The principal function of subsurface drainage is to prevent, eliminate, or control a high water table. Lowering the water table can improve growing conditions for crops, the condition of the soil surface, and trafficability on the field as well as around the farmstead. It also facilitates tillage practices.

Subsurface drainage also provides a period to apply agricultural wastes during high and prolonged rainfall seasons, and it maintains water intake and soil profile storage capacity, thereby reducing runoff during high rainfall periods. This type of drainage functions in irrigated areas to control saline and sodic soil conditions by removing excess salt accumulations, to provide for subirrigation, to help control seepage from canals and laterals, and to remove excess irrigation water from sources upslope as well as onsite. Subsurface drainage is accomplished by various kinds of buried or open drains.

**(a) Plans**

A plan should be made of every subsurface drainage layout. The size and detail of the plan vary in different locations; however, the plan should have the basic information required for the construction of the subsurface drainage system. Figures 14-24 and 14-25 are an example of a subsurface drain plan and layout.

**(b) Soils**

Subsurface drainage is applicable to saturated soil conditions where it is physically and economically feasible to use buried conduits to remove or control free water from the root zone.

The need for and the design of subsurface drainage systems are related to the amount of excess water entering the soil from rainfall, irrigation, or canal seepage; the permeability of the soil and underlying subsoil material; and the crop requirements. In soils with slow permeability that causes water to flow

slowly into the drain, the drains must be closely spaced. Consequently, installation may be considered too expensive for use of subsurface drains.

Soils must have sufficient depth and permeability to permit installation of an effective and economical subsurface drainage system. Some sandy soils and peat and muck have large pore spaces that allow rapid movement of water. Wetness occurs in these soils because of a high water table, particularly in the spring in nonirrigated areas, late in summer, or during the irrigation period. For maximum crop yields, the wetness problem must be corrected by drainage. These soils can be successfully drained.

Some fine sand soils have insufficient colloidal material to hold the sand particles together. This can cause excessive movement of the particles into the drains. Special precautions, such as filters or envelopes, are often required.

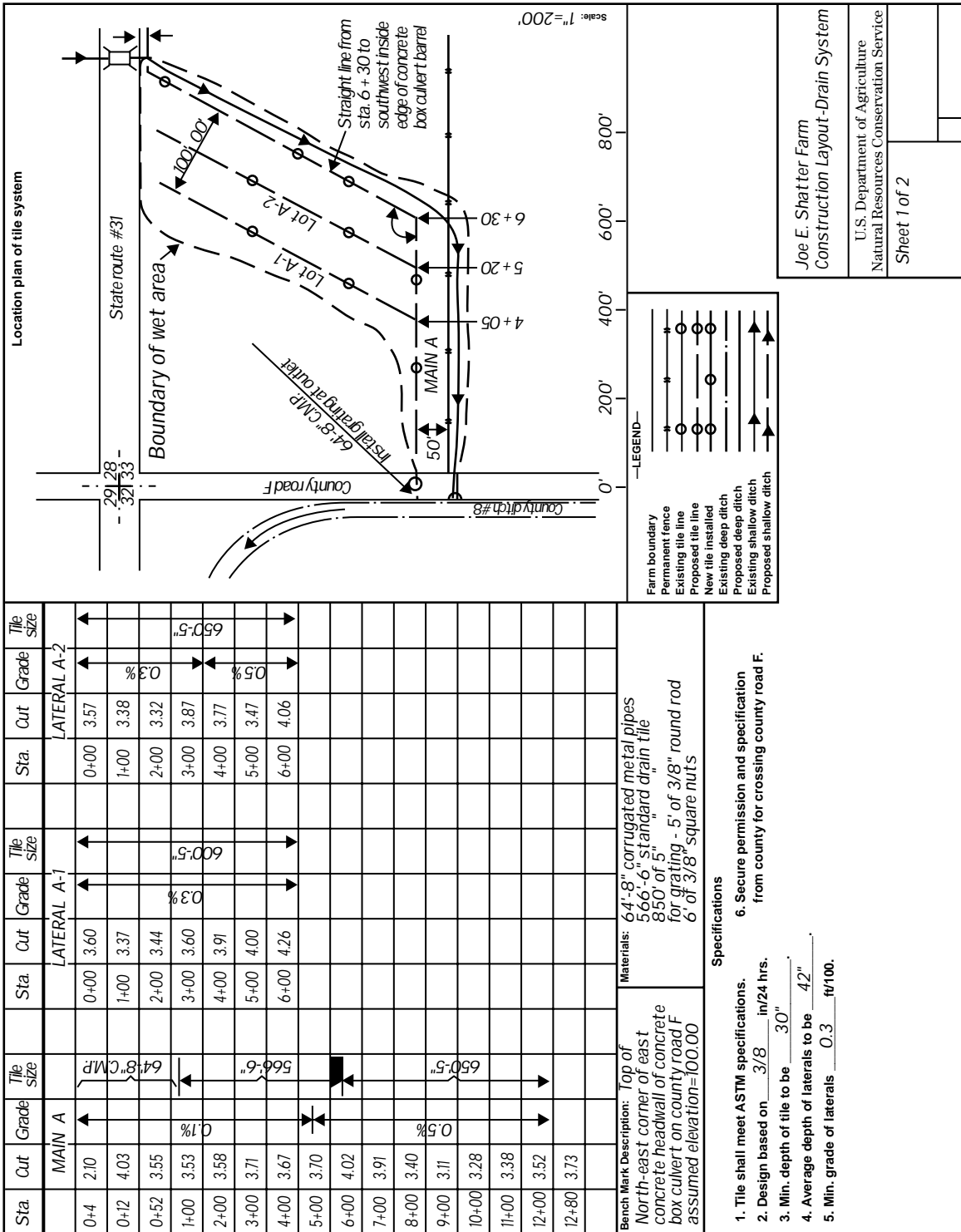
In highly permeable, coarse sands and some peat soils, excessive lowering of the water table causes a moisture deficiency during periods of drought. Such soils have limited capillary rise and are unable to deliver water up into the plant root zone of certain crops if the water table falls much below the root zone. Water table control systems should be used for these conditions.

Other soil conditions make construction of drains hazardous or impractical. In some soils, boulders or stones make drainage costs prohibitive. In others, the topsoil is satisfactory, but it is underlain by unstable sand at the depth where drains should be installed, thus making installation more difficult. A chemical action, which takes place in soils that have glauconite, iron oxide, or magnesium oxide, can cause drain joints or perforations to seal over.

In soils where iron is present in soluble ferrous form, ochre deposits in drain lines can be a serious problem. If the problem is recognized, it can be solved by making adjustments in design and maintenance of the drainage system.

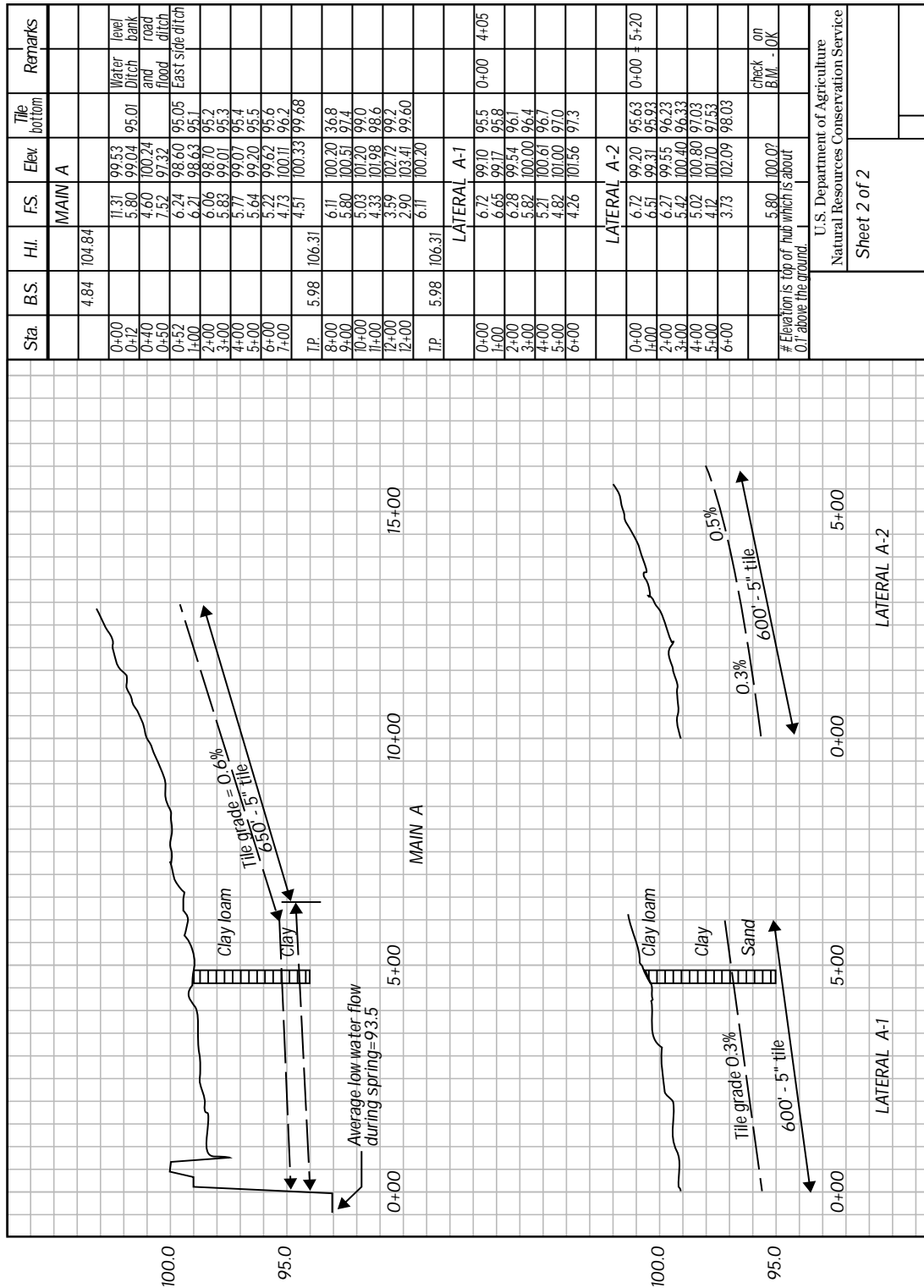
Ochre is formed as a combination of bacterial slimes, organic material, and oxidized iron. It is a highly visible, red, gelatinous, iron sludge that often occurs in the valleys of the corrugations of drain tubing as well as at the drain outlets.

**Figure 14-24** Subsurface drain plan





**Figure 14-25** Subsurface drain plan and layout



Soil conditions that contribute to ochre formation have been identified throughout the United States. Studies have shown a relationship among soil types, iron ochre, and related sludge deposits in subsurface drain lines. Four known sludge deposits are associated with bacterial activity in subsurface drains—ochre, manganese deposits, sulfur slime, and iron sulfide. Iron deposits, collectively named ochre, are the most serious and widespread of the sludge deposits. The ochre and associated slimes are a sticky mass that is generally red, yellow, or tan. This sticky mass can clog drain entry slots, drain envelopes, and the valleys of the corrugations between envelope and inlet slots. Such elements as aluminum, magnesium, sulfur, and silicon are often present.

The soils that tend to show the most hazard for ochre formation are fine sand, silty sand, muck or peat that has organic pans (spodic horizons), and mineral soils that have mixed organic matter. Those that have the least potential hazard of ochre are silty clay and clay loam. Sites used for spray irrigation of sewage effluent and cannery plant wastes generally furnish sufficient iron and energy for reduction reactions; therefore, the potential hazard of ochre deposits is serious.

In certain areas of the western United States, manganese, when present under suitable conditions in the ground water, can form a drain-clogging, gelatinous black deposit. Manganese has not been a serious problem in the Eastern United States.

Sulfur slime is a yellow to white stringy deposit formed by the oxidation of the hydrogen sulfide in ground water. This slime has not been a serious problem in most agricultural drains. It is most frequent in muck soils. It may be on sites designed for subirrigation if the well water used for irrigation contains hydrogen sulfide.

### (c) Economics

Some soils can be drained satisfactorily, but the installation cost of drainage structures is so great that the benefits derived do not justify the expense. In most instances, drain spacing of less than 40 feet for relief (field) drainage can be justified where high value crops or substantial indirect benefits are involved. For example, indirect benefits should be considered where the drying of soil in orchards makes it possible for spray rigs and harvesting equipment to be used without bogging down and where agricultural wastes can be applied during high and prolonged rainfall periods.

Some soil can be drained satisfactorily, but inherent productivity is so low that yields do not justify the expense. Suitable outlets and disposal for drainage effluent may not be available at an acceptable cost. Even if returns from increased crop yields and reduction in the cost of production should pay for drain system installation within 5 to 10 years, the financial ability of the land user may not allow such an investment. Final economic decisions should be made by the landuser based on best estimate of cost and benefits.

### (d) Use of local guides

Drainage recommendations for the varied soil types, soil conditions, crops, and economic factors can be made only in general terms. Because investigational procedures, planning, and methods of improving drainage conditions differ in many sections of the country, local technical guides and State drainage guides should be consulted for recommendations and procedures for agricultural drainage. Local and State regulations for disposal of drainage water must be complied with.

## 650.1421 Applications of subsurface drainage

### (a) Field drainage

Relief drains are those installed to remove excess ground water percolating through the soil or to control a high water table. They should systematically lower the water table for an area. The drains may be aligned parallel or perpendicular to the direction of ground water flow.

Relief drains will develop similar drawdown conditions on either side of the drain, and, if the soil is homogeneous, the water table on either side will be the same at equal distances from the drain.

### (b) Interception drainage

Interception drains are installed at right angles to the flow of ground water to intercept subsurface flows. The drainage is applicable to broad, flat areas that are wet because of seepage from canals or adjoining highlands. Drains for interception of seep planes must be located properly to dry wet areas caused by upslope water. Seep planes are first located by soil borings, and then the drain is located so that continuous interception of such seep planes, adequate soil cover over the drain, and uniform grade to an available outlet are established. In steeply graded depressions or draws, a layout may include a main or submain drain in the draw or to one side of the draw, with the interceptor lines across the slope on grades slightly off contour.

### (c) Drainage by pumping

The objective of all subsurface drainage is to remove or control excess water from the root zone of the crop. This generally is accomplished by installing subsurface drains or open ditches. Water table levels may also be controlled by pumping from the ground water reservoir to maintain the upper limit of the water table level. In some irrigated areas where irrigation water is obtained from wells, irrigation and drainage may both

be affected by the pumping of wells. This combination of practices is limited to areas where the soil has low salinity and a proper salt balance can be maintained. In salty areas where drainage is accomplished by pumping, the drain water is generally discharged into a natural outlet or planned disposal system and not directly reused for irrigation. In some cases the drain effluent can be used conjunctively with a water source of higher quality, making the water suitable for irrigation use.

Planning pump drainage can be quite complex. Detailed information on the geologic conditions and the permeability of soil and subsoil material is important. Design involves anticipating what the shape and configuration of the cone of depression will be after pumping. This, in turn, involves spacing of wells with respect to their areas of influence to obtain the desired drawdown over the area to be drained. Experience with this type of drainage indicates that it is costly and consideration of its use may be limited to high-producing lands that have a high net return per acre.

### (d) Mole drainage

Mole drains are cylindrical channels artificially produced in the subsoil without trenching from the surface. Various kinds of plastic liners and methods of installation of the liners have been tried with varying degrees of success. The object of the lining is to extend the life of the mole channel.

Mole drainage is used in organic soils and soils with a dense, impervious, fine-textured subsoil and normally in more undulating areas. The problem is not the control of a ground water table (which may be very deep), but the removal of excess water from the field surface or from the topsoil. The water reaches the mole channel mainly through fissures and cracks formed during installation of the mole opening. The outflow from mole drainage systems differs considerably from that of subsurface drainage systems controlling the ground water table. Normally, the outflow from mole drainage systems show a quick response to rainfall or irrigation water; thus, as the water application or rainfall event ceases, the outflow ends quickly. The time lag between water intake at the surface and drain outflow is a few hours at most.

Experience with use of mole drainage in the United States is so variable that it is impractical to describe its use here. Refer to the National Engineering Handbook, section 16 (NEH-16), for general information and to local field office technical guides for specific information.

### (e) Water table management

Water table management is the operation and management of a ground water table to maintain proper soil moisture for optimum plant growth, to sustain or improve water quality, and to conserve water. It is the operation of a subsurface drainage system for the purpose of lowering the water table below the root zone during wet periods (drainage), raising the water table during dry periods (subirrigation), and maintaining the water table during transition (controlled drainage). For more information, refer to Subchapter E, Controlled and reversible drainage.

### (f) Salinity control

Salinity control is practiced for both irrigated cropland and dryland farming operations. The same salt balance principles apply, but the source of the salts and the water source and management must be understood and treated appropriately.

Drainage for salinity control on dry land commonly intercepts and removes excess ground water upslope of areas in which the subsoil has a high salt content. The excess water may come during high precipitation periods, noncrop growing periods, or during heavy snow accumulation. Removal of the excess water above the seep prevents the accumulation of salts left by the surfacing of the fluctuating water table. Drainage facilities may be used alone or in combination with special agronomic practices to manage the excess water.

### (1) Dryland salinity management

Management of dryland seeps is described in detail in chapter 17 of the Agricultural Salinity Assessment and Management Manual Number 71 (ASCE 1990). Because interception drainage may play an important role in management of ground water, refer also to the subchapter on interception drainage. Open interceptor drains may be effective and better suit a particular site condition than a subsurface drain.

Saline or sodic conditions can also occur on non-irrigated land at or near sea level in coastal areas. Controlled drainage structures or pumping systems may be needed to make a drainage system function satisfactorily.

### (2) Salinity management for irrigated conditions

The management of saline conditions in irrigated agriculture is practiced more extensively and perhaps better understood. The source of the salts is generally from the irrigation water. As the water is used by evapotranspiration, the salts are either leached below or out of the root zone, or they are left to accumulate in the root zone. If the salts are left to accumulate in the soil profile, a noticeable reduction in yield occurs, depending on the specific crop tolerance. Monitoring salinity level of soil-moisture is shown in figure 14–26. To correct this situation, a natural or supplied source

**Figure 14–26** Monitoring salinity level of soil-moisture



of water is used to leach the salts beyond or out of the root zone. If natural drainage is not adequate to discharge the saline water, then a drainage system needs to be installed. The depth and spacing of subsurface drain tubes are generally much greater in irrigated areas of the Western United States compared to subsurface drainage systems in the humid eastern region.

The proper operation of a productive and sustainable irrigated agriculture, especially when using a saline water source, requires periodic information on the levels and distribution of soil salinity within the crop root zones. Direct monitoring in the field is the most effective way of determining where and when soil salinity conditions need corrective action. Figure 14-26 shows a team of specialists measuring the soil salinity level in the root zone of a cotton crop that is irrigated with moderately saline water. In addition to hand-held equipment in recent years mobile equipment has been perfected to spatially monitor infield soil salinity conditions. Refer to Appendix 14C Salinity Monitoring Equipment.

Reuse or disposal of saline drainage water has received a lot of attention and special studies in recent years (ASCE 1990). Saline water may be used for more tolerant crops, or the timing of saline water use on crops may be adjusted till the crop growth stage will tolerate the increased saline level without hampering quality or yield. Because reuse of different quality water for sustainability of production is a complex activity, this should only be undertaken after consultation with skilled specialists. Refer to NEH-16 (NRCS 1971); NEH, Part 652, Irrigation Guide, chapters 2 and 13; and ASCE Manual 71 (ASCE 1990) for additional guidance.

### (g) Residential and non-agricultural sites

A major application of subsurface drainage in non-agricultural settings is for foundation, basement, and lawn areas of residential homes. Refer to the appendix 14F. A recent publication on this subject matter is the Urban Subsurface Drainage Manual, referred to as Manual of Engineering Practice 95 (ASCE, 1998).

## 650.1422 Investigations and planning

### (a) Topography

The amount of surveying needed to obtain topographic information depends on the lay of the land. Where land slopes are uniform, only limited survey data are needed to locate drains. On flat or slightly undulating land, proper location of drains is not obvious, and a topographic survey is necessary. Sufficient topographic information should be obtained for planning of the complete job. Insufficient data often result in a piecemeal system, which can eventually be more costly to the landowner. Methods for making topographic surveys and maps are covered in chapter 1 of this handbook.

### (b) Soils

Unless sufficient soil borings were taken during the preliminary investigation, more should be taken as part of the design survey. The number of borings necessary depends upon variations in the subsoil material. Borings should be in sufficient number and depth to determine the extent of soil texture variations and to locate any lines of seepage, water movement, or water table elevations.

Permeability (hydraulic conductivity) of the soil should be determined at each change in soil layers when making the borings. Soil permeability should be determined by the auger hole or other field methods as described in 650.1423(e).

If the hydraulic conductivity tests cannot be performed because a water table is not present, the system could be planned using estimated soil hydraulic conductivity. Hydraulic conductivity can vary significantly within the same soil in any given field; thus estimates should be used carefully. Estimates can be made for each soil using the Mapping Unit Interpretations Record (MUIR) as shown in figures 14-27 and 14-28. The MUIR lists permeability values that can be used as hydraulic conductivity in lieu of measured values.

**Figure 14-27** Estimating soil hydraulic conductivity using soil interpretation record

NC0128 PORTSMOUTH SERIES

MLRA(S): 153A, 133A, 153B, 153C  
REV JHW, ENH, 2-89  
TYPIC UMBRAQUULTS, FINE-LOAMY OVER SANDY OR SANDY-SKELETAL, MIXED, THERMIC

THE PORTSMOUTH SERIES CONSISTS OF VERY POORLY DRAINED, NEARLY LEVEL SOILS ON FLATS AND SLIGHT DEPRESSIONS ON THE LOWER COASTAL PLAIN AND STREAM TERRACES IN A REPRESENTATIVE PROFILE, THE SURFACE LAYER IS BLACK FINE SANDY LOAM ABOUT 12 INCHES THICK. THE SUBSURFACE LAYER IS GRAY FINE SANDY LOAM ABOUT 7 INCHES THICK. THE SUBSOIL IS MOTTLED GRAY AND DARK GRAY FINE SANDY LOAM IN THE UPPER PART, SANDY CLAY LOAM IN THE MIDDLE PART, AND SANDY LOAM IN THE LOWER PART. THE SUBSOIL IS ABOUT 19 INCHES THICK IS UNDERLAIN BY GRAY SAND AND COURSE SAND TO 72 INCHES. SLOPES RANGE FROM 0 TO 2 PERCENT.

| LANDSCAPE AND CLIMATE PROPERTIES |                 |                      |                |                |             |
|----------------------------------|-----------------|----------------------|----------------|----------------|-------------|
| ANNUAL AIR TEMPERATURE           | FROST FREE DAYS | ANNUAL PRECIPITATION | ELEVATION (FT) | DRAINAGE CLASS | SLOPE (PCT) |
|                                  |                 |                      |                | VP             | 0-2         |

| ESTIMATED SOIL PROPERTIES |                     |                   |               |                     |                      |  |        |       |       |            |
|---------------------------|---------------------|-------------------|---------------|---------------------|----------------------|--|--------|-------|-------|------------|
| DEPTH (IN.)               | USDA TEXTURE        | UNIFIED           | AASHTO        | FRACT. >10 IN (PCT) | FRACT. 3-10 IN (PCT) | PERCENT OF MATERIAL LESS THAN 3" PASSING SIEVE NO. |        |       |       | CLAY (PCT) |
|                           |                     |                   |               |                     |                      | 4  | 10     | 40    | 200   |            |
| 0-19                      | MK-SL, MK-FSL, MK-L | SM, SM-SC, ML, SC | A-2, A-4      | 0                   | 0                    | 98-100   | 98-100 | 65-95 | 30-65 | 10-25      |
| 0-19                      | SL, FSL, L          | SM, SM-SC, ML     | A-2, A-4      | 0                   | 0                    | 98-100   | 98-100 | 65-95 | 30-65 | 5-25       |
| 0-19                      | SIL                 | ML, CL            | A-6, A-7      | 0                   | 0                    | 95-100   | 90-100 | 85-95 | 65-80 | 20-27      |
| 19-35                     | L, SCL, CL          | SC, CL-ML, CL     | A-4, A-6      | 0                   | 0                    | 98-100   | 98-100 | 75-95 | 36-70 | 20-35      |
| 35-38                     | LS, SL              | SM                | A-2           | 0                   | 0                    | 98-100   | 98-100 | 50-70 | 13-35 | 8-18       |
| 38-72                     | SR-COS-LS           | SP-SM, SP, SM     | A-1, A-2, A-3 | 0                   | 0                    | 98-100   | 98-100 | 45-65 | 3-25  | 2-10       |

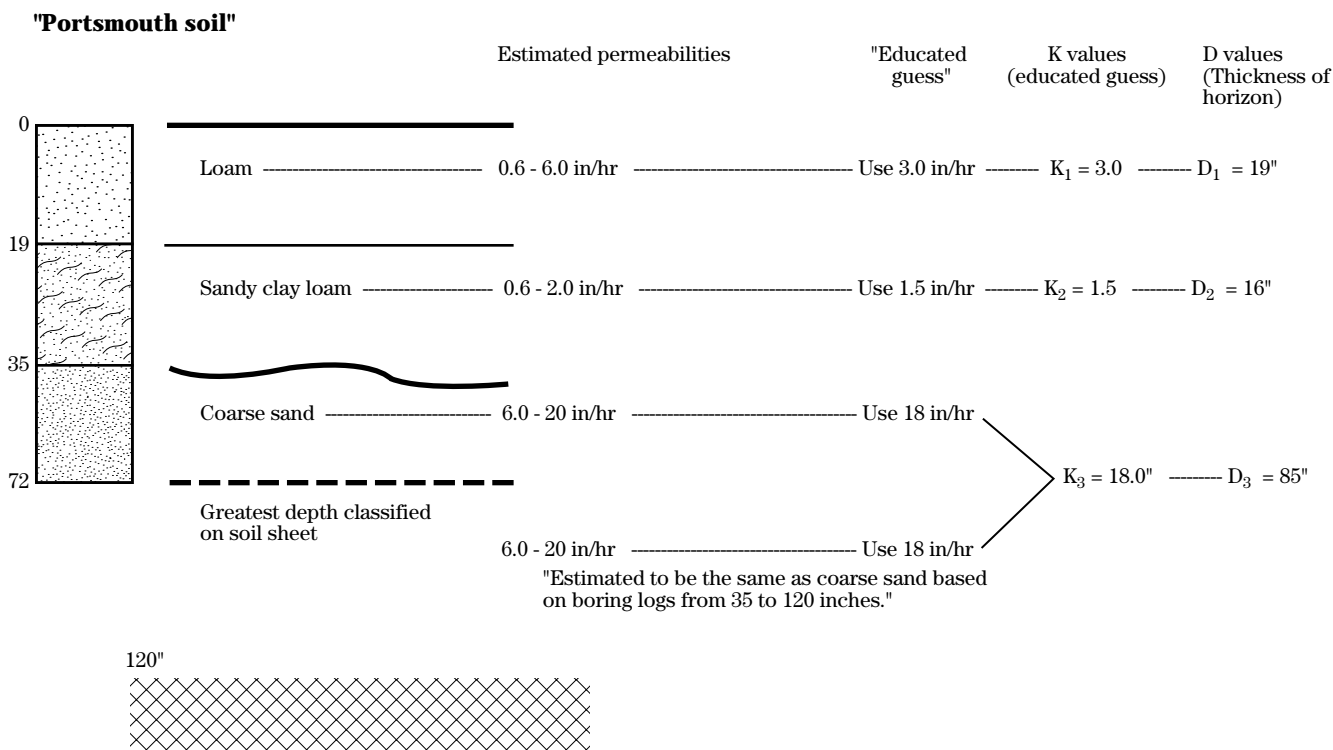
  

| DEPTH (IN.) | LIQUID LIMIT | PLASTICITY INDEX | MOIST BULK DENSITY (G/CM3) | PERMEABILITY (IN/HR) | AVAILABLE WATER CAPACITY (IN/IN) | SOIL REACTION (PH) | SALINITY (MMHOS/CM) | SAR | CEC (ME/100G) | CACO3 (PCT) | GYPSUM (PCT) |
|-------------|--------------|------------------|----------------------------|----------------------|----------------------------------|--------------------|---------------------|-----|---------------|-------------|--------------|
|             |              |                  |                            |                      |                                  |                    |                     |     |               |             |              |
| 0-19        | <30          | NP-7             | 1.30-1.40                  | 0.6-6.0              | 0.12-0.18                        | 3.6-5.5            | -                   | -   | -             | -           |              |
| 0-19        | 30-45        | 10-25            | 1.50-1.60                  | 0.6-2.0              | 0.18-0.24                        | 3.6-5.5            | -                   | -   | -             | -           |              |
| 19-35       | 18-40        | 7-18             | 1.45-1.55                  | 0.6-2.0              | 0.14-0.20                        | 3.6-5.5            | -                   | -   | -             | -           |              |
| 35-38       | <18          | NP-4             | 1.40-1.60                  | 2.0-6.0              | 0.06-0.10                        | 3.6-5.5            | -                   | -   | -             | -           |              |
| 38-72       | -            | NP               | 1.40-1.65                  | 6.0-20               | 0.02-0.05                        | 3.6-6.0            | -                   | -   | -             | -           |              |

| DEPTH (IN.) | ORGANIC MATTER (PCT) | SHRINK-SWELL POTENTIAL | EROSION FACTORS K T | WIND EROD. GROUP | WIND EROD. INDEX | CORROSIVITY |           |
|-------------|----------------------|------------------------|---------------------|------------------|------------------|-------------|-----------|
|             |                      |                        |                     |                  |                  | STEEL       | CONCRETE  |
| 0-19        | 8-15                 | LOW                    | .24                 | 5                | 3                | 86          | HIGH HIGH |

**Figure 14-28** Soil profile with calculations of hydraulic conductivity using soil interpretation record



Saline and sodic problems are most common in arid and semi-arid climates. Where salt crusts are visible or salinity is suspected, the soil should be sampled at various depths. A record of the species and condition of plant cover is important. More details about saline and sodic problems are in ASCE Manual 71 (ASCE 1990) and local drainage guides.

Soil investigations should be conducted to estimate the maximum potential for ochre development in the planned drainage system.

### (c) Biological and mineral clogging

The ferrous iron content of the ground water flowing into a drain is a reliable indicator of the potential for ochre development. Soluble ferrous iron flowing in ground water enters a different environment as it approaches the drain and passes through the drain envelope. If the level of oxygen is low, certain filamentous and rod-shaped bacteria can precipitate insoluble ferric iron and cause its incorporation into the complex called ochre. The amounts of iron in ground water that can stimulate bacteria to produce ochre can be as low as 0.2 ppm.

Laboratory and field methods are available to estimate the ochre potential for a given site. Of particular importance is whether ochre may be permanent or temporary. Temporary ochre occurs rapidly, usually during the first few months after drain installation. If the drains can be cleaned or maintained in functional order, the ochre problem may gradually disappear as the content of iron flowing to the drains is reduced. Such soil environments must be low in residual organic energy sources to prevent the continual release of iron during short-term flooding.

Permanent ochre problems have been found in profiles with extensive residual iron, such as cemented iron subhorizons or rocks, and from iron flowing in from surrounding areas. Many factors influence ochre deposition, including the pH, type, temperature, and reducing conditions of the soil.

Certain onsite observations may give clues to potential ochre formation before a drainage system is installed. Surface water in canals may contain an oil-like film that is iron and may contain *Leptothrix* bacterial

filaments. Gelatinous ochre may form on the ditch-banks or bottom of canals. Ochre may also form within layers of the soil. Iron concretions, sometimes called iron rocks, are in some areas. The presence of spodic horizons (organic layers) suggests ochre potential; and most organic soils, such as mucks, have some potential for ochre problems.

If a site has potential for ochre deposits, certain planning and design practices should be followed to minimize this hazard to the system. No economical, long-term method for effectively controlling this problem is known. For sandy soils where a filter is necessary, a graded gravel envelope is best, although it can become clogged under conditions of severe ochre potential. When synthetic fabrics were evaluated for ochre clogging, the knitted polyester material showed the least clogging.

A submerged outlet may be successfully used to minimize ochre development with the entire drain permanently under water. The line should be completely under water over its entire length throughout the year. This may require that the drains be on flat grade. The depth of ground water over the drain should be at least 1 foot.

Herringbone or similar drain designs should have entry ports for jet cleaning.

Use drain pipe that has the largest slots or holes allowed within the limits of drain pipe and envelope standards. Slots or holes should be cleanly cut and should not have fragments of plastic to which ochre can adhere. Both smooth bore and corrugated pipes can accumulate ochre.

### (d) Ground water

Water table contour maps and depth to water table maps are very useful in planning subsurface drainage. The elevation of the water table at selected points, as obtained from borings, is plotted on a topographic map of the area. By interpolation, lines of equal water table are drawn. The result is a contour map of the water table. Where a ground surface contour crosses a water table contour, the depth to the ground water is the difference in elevation of the two contours. Areas that have a range of depths can be delineated on the map. The direction of ground water flow and extent of

high water table areas are also shown on the map. For additional information on the preparation and use of the water table contour maps, refer to National Engineering Handbook, part 623 (section 16), chapter 10.

## (e) Outlets

### (1) System outlets

The starting point in planning a subsurface drainage system is normally the location of the outlet. Drains may discharge by gravity into natural or constructed drains. Any of these outlets are suitable if they are deep enough and of sufficient capacity to carry all the drainage water from the entire drainage system. The adequacy of the outlet should be determined before proceeding with the design of the system.

### (2) Capacity and depth of open ditch outlets

The outlet ditch must have the capacity to remove the drainage runoff from its watershed quickly enough to prevent crop damage. It should be deep enough to allow at least 1 foot of clearance between the flow line of the drain and the normal low water stage in the ditch when drains are installed at the specified depth.

### (3) Capacity and depth of subsurface outlets

If existing subsurface drains are used for the outlet, they should be in good condition and working properly. The main drain should have sufficient capacity to handle the proposed drainage system in addition to other systems it serves, and it should be deep enough to permit the new system to be installed at the depth specified.

### (4) Pump outlet

An outlet by pumping should be considered for drainage sites where a gravity outlet is not available. Refer to subchapter F for information on pumped outlets.

### (5) Vertical drain outlet

A vertical drain is a well, pipe, pit, or bore, drilled into porous underlying strata, into which drainage water can be discharged. It is sometimes called a drainage well.

Wells tap permanent sources of ground water for livestock and domestic use. In some areas, shallow wells are the only reasonable and available water source for domestic use and must be protected from contaminants in agricultural drainage water. Public health laws in some States regulate the use of wells for drainage, and in many cases, prohibit this use because of the potential contamination of ground water and the danger to public health. However, in some parts of the country vertical drainage is a satisfactory solution to drainage water disposal and deep ground water recharge.

Where the possibility of using wells for a drainage outlet is considered, an engineer or geologist, or both, should assist in the investigation and planning.



## 650.1423 Field drainage system design

To plan a field drainage system, a pattern should be selected that fits the topography, sources of excess water, and other field conditions. The following basic systems may be considered (fig. 14–29).

### (a) Random system

A random field drainage system is used where the topography is undulating or rolling and has isolated wet areas. The main drain is generally placed in the lowest natural depression, and smaller drains branch off to tap the wet areas. Because such drains often become outlets for a more complete system established in the higher areas of the field, the depth, location, and capacity of the random lines should be considered as part of a complete drainage system. Generally, the logical location of these drains obviously fit the topography.

### (b) Parallel system

The parallel field drainage system consists of laterals that are perpendicular to the main drain. Variations of this system are often used with other patterns. In many cases, the parallel system is desirable because it provides intensive drainage of a given field or area. It can also be used in depressional or low areas that can be graded before installation of the system.

### (c) Herringbone system

The herringbone field drainage system consists of laterals that enter the main drain at an angle, generally from both sides. If site conditions permit, this system can be used in place of the parallel system. It can also be used where the main is located on the major slope and the lateral grade is obtained by angling the laterals upslope. This pattern may be used with other patterns in laying out a composite system in small or irregular areas.

### (d) Drainage coefficient

#### (1) Humid areas

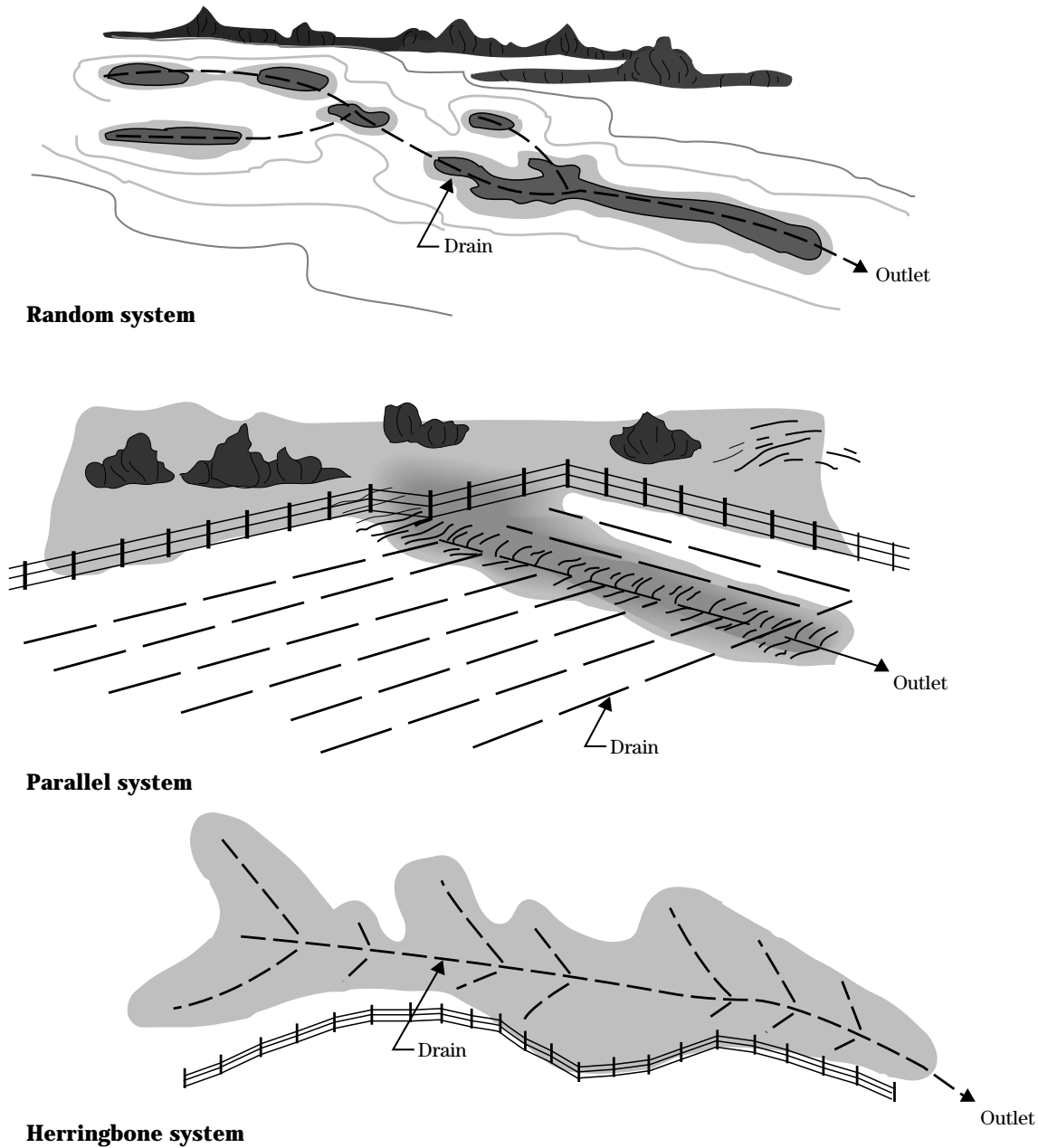
Drains should have sufficient capacity to remove excess water from minor surface depressions and the major part of the root zone within 24 to 48 hours after rainfall ceases. The required amount of water to be removed in some specified time is the drainage coefficient. For field drainage, it is expressed as inches of water depth to be removed over a safe period of time, generally 24 hours, or as an inflow rate per unit length of drain. Because of the differences in soil permeability, climate, and crops, as well as the manner in which water may enter the drain (i.e., all from subsurface flow or part from subsurface flow and part from surface inlets), the coefficient must be modified to fit site conditions in accordance with local drainage guides or within the approximate limits as follows:

- Where drainage is uniform over an area through a systematic pattern of drains and surface water is removed by field ditches or watercourses, the coefficient should be within the range as shown in table 14–5. Figure only the area to be drained as the drainage area.
- Where surface water, including roof runoff, must be admitted through surface inlets to the drain, an adjustment in the capacity of the drain is required. Runoff from an area served by a surface water inlet takes place soon after the rainfall and enters the drain ahead of the ground water. In short drainage lines or small systems that have only one or two inlets, the size of the drain may not need to be increased. As systems become larger or the inlets more numerous, an adjustment to the drainage coefficient should be made. The timing of the surface water flow in relation to the entrance of ground water into the drain should be the basis for increasing the coefficient over those shown in table 14–5.
- A higher coefficient than those given in table 14–5 is sometimes necessary to hold crop damage to a minimum. Refer to local drainage guides.

**Table 14–5** Drainage coefficients

| Soil    | Field crops                        | Truck crops |
|---------|------------------------------------|-------------|
|         | (inches to be removed in 24 hours) |             |
| Mineral | 3/8 – 1/2                          | 1/2 – 3/4   |
| Organic | 1/2 – 3/4                          | 3/4 – 1 1/2 |

**Figure 14-29** Field drainage systems



## (2) Arid areas

In areas where rainfall is light, drainage coefficients applicable to local areas are variable and depend upon the quality and amount of irrigation water applied, methods of irrigation, crops to be grown, and characteristics of the soil.

Local drainage guides and other information should be used to determine drainage coefficients. However, where experience is lacking, the following formula can be used to estimate drainage coefficients. The deep percolation volume must be accounted for, including leach water that must be added to maintain a favorable salt balance in the soil and the water that is a result of inefficient or excess irrigation. This formula does not account for upslope water sources or upward flux from ground water.

$$q = \frac{P + C}{24F} (i)$$

where:

- q = drainage coefficient, inches/hour
- P = deep percolation from irrigation including leaching requirement, percent (based on consumptive use studies)
- C = field canal losses, percent
- i = irrigation application, inches
- F = frequency of application, days

A graphical solution to the formula is provided in the chart in figure 14–30. An example problem solved by graphical method follows.

### Example:

Assume:

- Total loss ( $P+C$ ) = 30 percent
- Irrigation application ( $i$ ) = 6 inches
- Frequency of application ( $F$ ) = 8 days

Using figure 14–30, find 30 on the left vertical scale; follow horizontally from this point to intersect with line ( $i$ ) = 6 in. Translate this point vertically to intersect line ( $F$ ) = 8. Follow horizontally from this point to the right scale and read 0.0092 inches per hour as the drainage coefficient.

## (e) Hydraulic conductivity

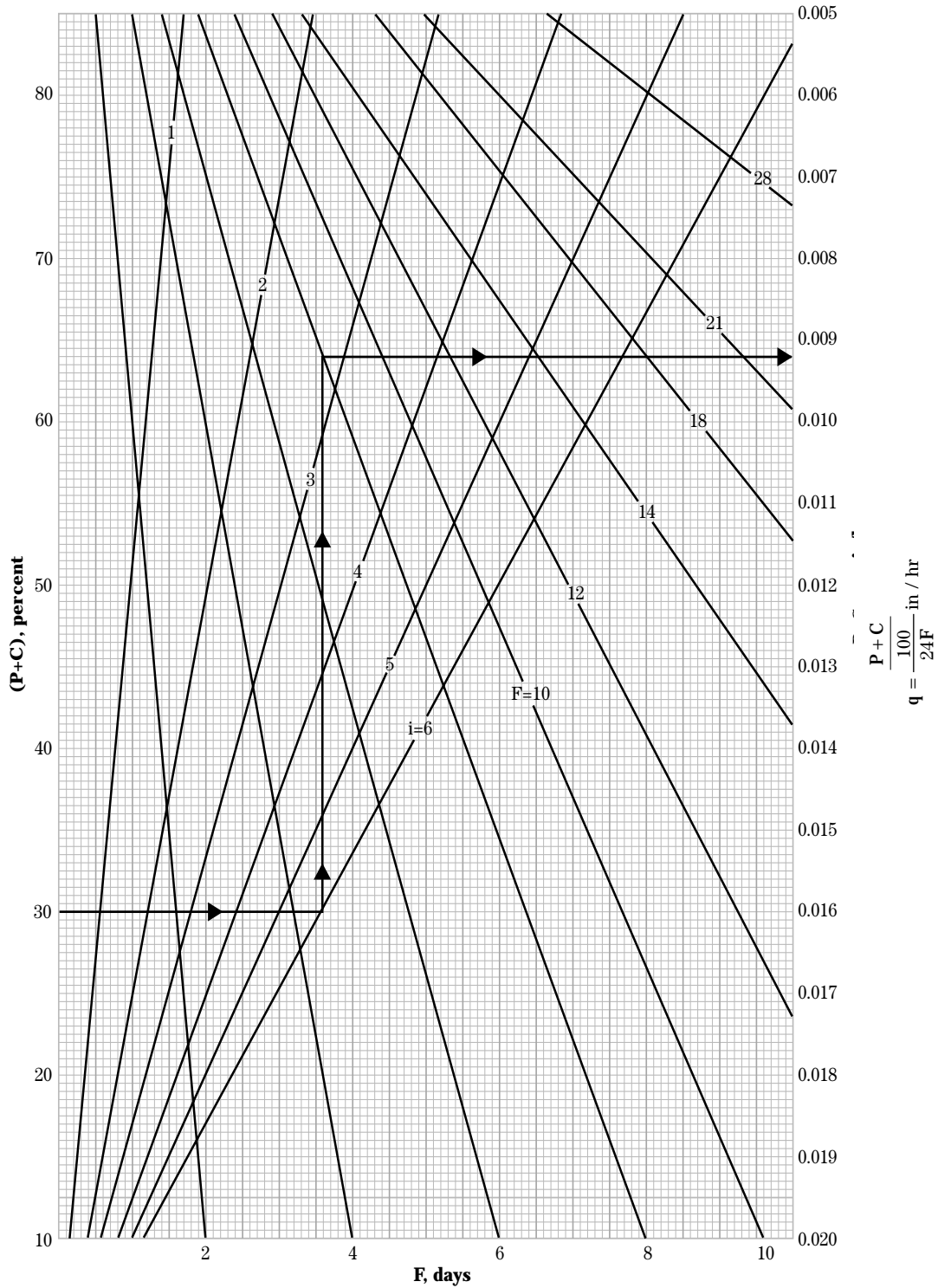
Any drainage survey should involve a hydraulic conductivity ( $K$ ) investigation in the field. Twice the depth of drains or the top 7 feet of the soil profile, whichever is less, can be surveyed using the auger hole method. When using this method, the observation points should be selected according to available soil maps and information on soil morphology and its lateral variation pattern in relation to physiography. Typically, the intensity of a hydraulic conductivity survey for the purpose of project design varies from one hole per 10 acres to one hole per 20 acres, depending on the degree of homogeneity in the obtainable values. Maps should be prepared at a suitable scale showing the  $K$  values differentiated, if possible, for hydraulic conductivity above and below drain level and also showing depths to an impermeable stratum if one exists. All auger holes should be drilled at least to the depth the drains will be installed. It is advisable to extend one hole in 10 to the relatively impermeable layer (barrier), three holes in 10 to a depth below the drain level, and six holes in 10 to the depth of the drain level. Appendix 14D describes the auger hole procedure.

A farm or large field on which the values of hydraulic conductivity are quite uniform may be given an average value by simple calculation of the arithmetic mean. Sometimes the farm or field must be divided into sections, each having values that are uniform but whose averages are different.

Areas with an average hydraulic conductivity of 0.3 foot per day or less normally are not provided with subsurface drainage. The chosen figure, 0.3 foot per day, is based on economic considerations. Hydraulic conductivity is subject to change with time as a result of alternate drying and wetting of the soil or by changes in the soil structure through chemical or mechanical means, as well as the farming practices.

Isolated spots of very low hydraulic conductivity may be encountered on farms that are otherwise reasonably permeable. These spots should not be included in the average. The drainage of such localized impermeable mounds is best achieved by draining the surrounding, more permeable soil into which these mounds can then dewater. Installation of subsurface drainage systems in such impermeable soil should be avoided. In some situations shallow, open field ditches

**Figure 14-30** Curves to determine drainage coefficient,  $q$ , for arid areas



may be feasible. The landowner decides on the feasibility of installing a drainage system with an appropriate drain spacing. Some over or under drainage is inevitable, thus the decisionmaker should be informed of these potential irregularities as decisions are made on spacings.

### (f) Depth of impermeable layer

The impermeable layer (barrier) is not necessarily a more fine textured subsoil. It may be a product of other factors, such as consolidation by the weight of glaciers or a stratification of alluvial sediment.

The impermeable layer can be defined as a layer with a hydraulic conductivity value of one-tenth or less than that of the soil stratum containing the water table through which the drainage water moves towards the field drains. In that regard, the effects of possible up or downward seepage through the impermeable layer have been neglected, and any lateral seepage (resulting from canal leakage or hillside seepage) is not considered.

The influence of an impermeable layer on the behavior of a ground water table depends on its depth below the level of field drains and on the drain spacing. The flow pattern of the water moving toward the drain is altered drastically by the impermeable layer if the drain level above the impermeable layer is less than a fourth the spacing between drains. The drains need to be placed closer together to achieve the effect they would have in a deep permeable soil. However, if the depth of the impermeable layer below drain level exceeds a fourth of the drain spacing, the flow system can be treated as if such a layer was absent.

### (g) Depth and spacing

The two basic formulas to determine spacing are the steady state and the nonsteady state, also called transient state. A basic form of the steady state equation, referred to as the ellipse equation, is presented in this section. The importance of a good drainage formula for depth and spacing is often overestimated. The

transient state formula may better relate actual conditions than the ellipse equation, but the accuracy of results from any of the accepted equations is controlled primarily by the accuracy of the assumed or measured parameters used in the calculations. The accuracy of the input parameters, especially hydraulic conductivity, may be in error by as much as 20 percent; therefore, a minor difference in the result of one equation over another is not that important. Sensitivity analysis of input parameters has been done and documented in conjunction with evaluations of DRAINMOD. For these reasons and to simplify use, it is justifiable to use the presented steady state equation.

The DRAINMOD computer program can satisfy the need for a more precise analysis of the water table fluctuations and resulting crop impact analysis. See DRAINMOD User's Guide (USDA NRCS 1994). If a transient state analysis is desired, refer to appendix 14E. Many field offices have locally developed drainage guides with recommended depth and spacing criteria related to the individual soil series as mapped and published in cooperative soil survey reports.

#### (1) Humid areas

Generally, the greater the depth of a field drain, the wider the spacing can be between drains. Other factors that help determine the depth and spacing are the soil, climate, subsurface barriers, frost depth, and crop requirements. Where the experience with drain installations is extensive, the depth and spacing of drainage systems in various soils are already well established.

Drains should be deep enough to provide protection against tillage operations, equipment loading, and frost. Initial settlement in organic soils should be considered in depth selection. Main and submain drains must be deep enough to provide the specified depth for outlets of lateral drains. Also, the maximum depth at which drains can be laid to withstand trench loading varies with the width of the trench and the crushing strength of the drain to be used. Allowable maximum depths are given later in this section.

In areas where drainage installations and knowledge of effective spacings are limited, the ellipse equation can be used to determine drain spacing.

$$S = \left[ \frac{4K(b^2 - a^2)}{q} \right]^{0.5}$$

where (see fig. 14-31):

$S$  = spacing of drains, feet,

$K$  = hydraulic conductivity, inches/hour

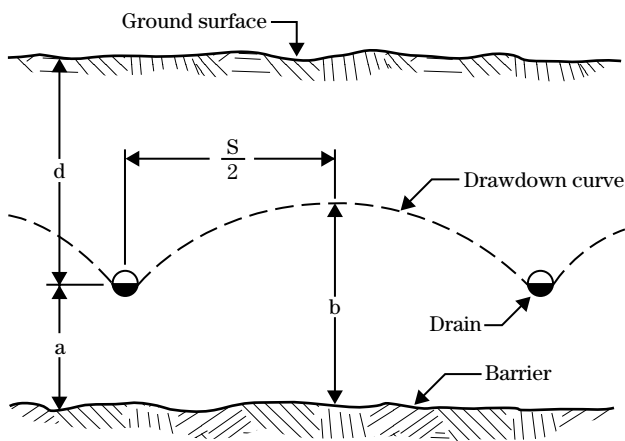
$b$  = distance from the drawdown curve to barrier stratum at midpoint between the drains, feet

$a$  = distance from drains to the barrier, feet

$q$  = drainage coefficient, inches/hour

**Note:** The units of  $K$  and  $q$  may also be in inches removal in 24 hours or gallons per square foot per day, but both must be in the same units in this formula. In using this formula for conditions where no known barrier is present, it is assumed that a barrier is present at a depth equal to twice the drain depth.

**Figure 14-31** Nomenclature used in ellipse equation



**Example:**

1. Parallel drains are installed at a depth of 6.0 feet ( $d = 6$ ).
2. Subsoil borings indicate an impervious barrier at 11 feet below the ground surface ( $a = 11.0 - 6.0 = 5.0$  feet).
3. Distance from ground surface to drawdown curve desired is 3 feet. Then ( $b = 11 - 3 = 8$  feet)
4. The hydraulic conductivity of subsurface materials ( $K$ ), is 1.2 inches/hour.
5. The applicable drainage coefficient ( $q$ ) is  $3/8$  inch removed in 24 hours, or 0.0156 inch/hour.

Then:

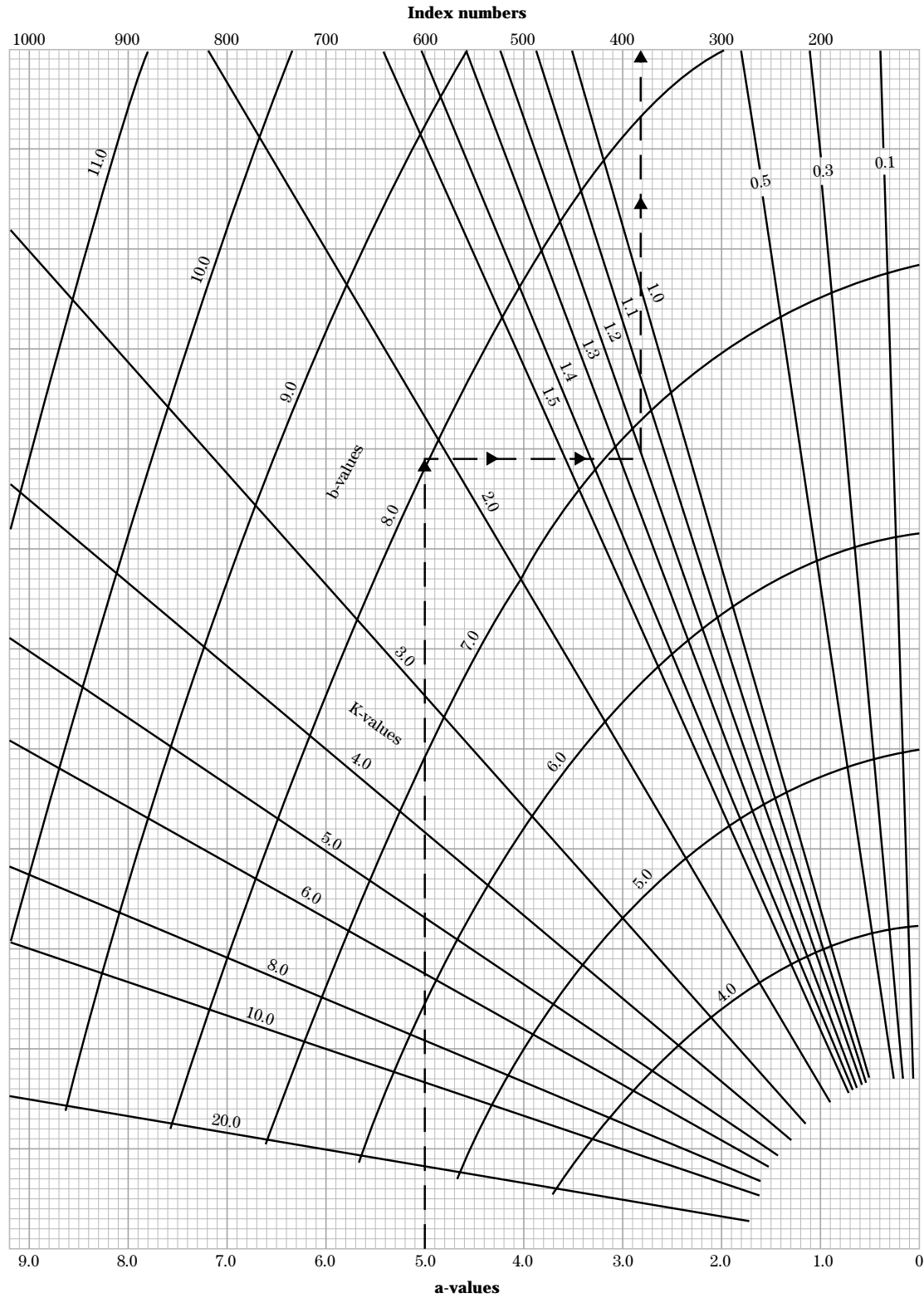
$$S = \left[ \frac{4(1.2)(8^2 - 5^2)}{0.0156} \right]^{0.5} = 109.5 \text{ ft} \quad (\text{use } 110 \text{ feet})$$

Charts for the graphical solution of the ellipse equation are shown in figure 14-32, sheets 1 and 2. Refer to the figure and solve the above example as follows:

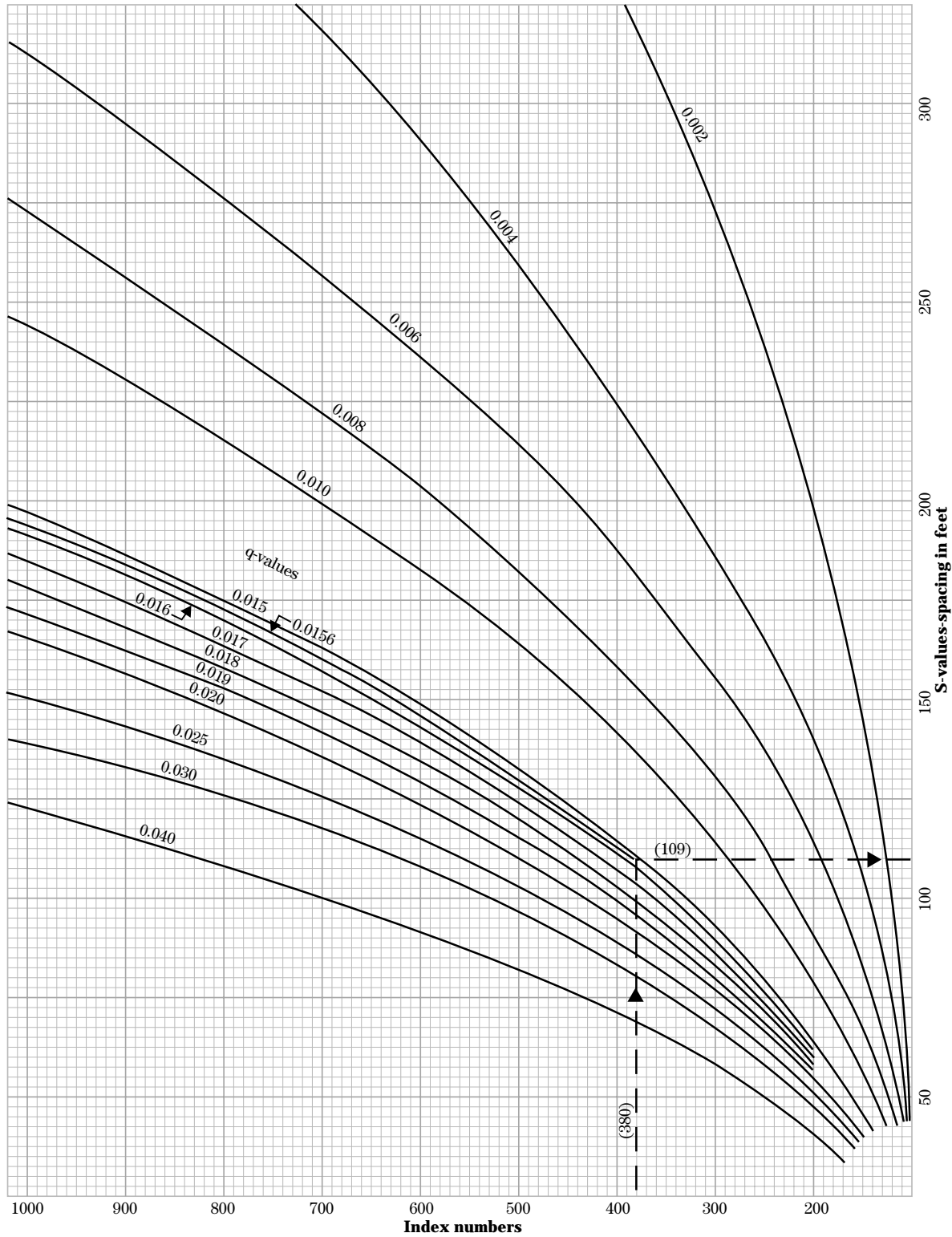
**Step 1.** On sheet 1, find [ $a = 5$ ] on the bottom scale. Project this point vertically to intersect the curve line [ $b = 8$ ]. From this point, follow horizontally to intersect radial line [ $K = 1.2$ ]. From this point go vertically to intersect the top scale. Read the index number of 380.

**Step 2.** On sheet 2, find index number (380) on the bottom scale. Project this point vertically to intersect the curve line [ $q = 0.0156$ ]. From this point, follow horizontally to the right vertical scale and read the spacing of [ $S = 109$  feet]. [Use 110 feet.]

**Figure 14-32** Graphical solution of ellipse equation (sheet 1 of 2)



**Figure 14-32** Graphical solution of ellipse equation (sheet 2 of 2)





**(2) Arid areas**

For field drainage systems, depth and spacing of drains are given in state drainage guides where experience has been extensive enough to determine the correct figures. Where this information is not available, the ellipse equation, as previously discussed, is used to determine the spacing of field drains.

To control salinity, drains generally are placed deeper in arid and semiarid irrigated areas than in humid areas. The minimum effective depth is 6 feet for medium textured soils and up to 7 feet for fine textured soils, assuming there is no barrier above this depth. This is necessary to maintain the ground water at a depth of 4 to 5 feet midway between the drains. In most cases, the depth of the laterals depends upon the outlet depth, slope of the ground surface, and depth to any barrier.

The depth capacity of the drain-laying machine may limit the depth of the drain unless provisions are made for ramping part of the line. In ramping, a depressed roadway is excavated for the machine to obtain the needed depth in the deeper reaches of the drain line.

If the outlet for the drain is not deep enough to permit its installation to the required depth, then outletting

into a sump with an automatic pump cycling may be considered. Refer to subchapter D for information on pumped outlets.

**(3) Allowable depths**

In most cases subsurface drains should not be placed under an impermeable layer, and they should be located within the most permeable layer. Economic depth should also receive consideration. Economic depth figures can easily be developed locally by evaluating changes in the cost for different depth and spacing ratios for each major soil type. The maximum depth at which subsurface drains can be safely laid varies with the crushing strength of the drain, type of bedding or foundation on which the drain will be laid, the width of the trench, and the weight of the backfill.

Temperature is also a factor to consider for installation and loading of thermoplastic pipe. The maximum depth of cover recommended for subsurface drains is given in the American Society of Agricultural Engineers (ASAE) Engineering Practice 260.4.

Table 14–6 is provided for guidance on maximum depth. The type of bedding depends upon construction methods. If a drain is installed by backhoe or dragline and the bottom of the trench is not shaped to conform

**Table 14–6** Maximum trench depths for corrugated plastic pipe buried in loose, fine-textured soils (feet) \*

| Nominal tubing diameter (inches) | Tubing quality (ASTM) | ----- Trench width at top of corrugated plastic pipe (feet) ----- |       |     |                  |
|----------------------------------|-----------------------|---|-------|-----|------------------|
|                                  |                       | (1)   | (1.3) | (2) | (2.6 or greater) |
| 4                                | Standard              | 12.8  | 6.9   | 5.6 | 5.2              |
|                                  | Heavy-duty            | §   | 9.8   | 6.9 | 6.2              |
| 6                                | Standard              | 10.2  | 6.9   | 5.6 | 5.2              |
|                                  | Heavy-duty            | §   | 9.5   | 6.6 | 6.2              |
| 8                                | Standard              | 10.2  | 7.2   | 5.6 | 5.2              |
|                                  | Heavy-duty            | §   | 9.8   | 6.9 | 6.2              |
| 10                               |                       | —   | 9.2   | 6.6 | 6.2              |
| 12                               |                       | —   | 8.9   | 6.6 | 6.2              |
| 15                               |                       | —   | —     | 6.9 | 6.2              |
| 18                               |                       |   |       |     |                  |

Note: Depths are based on limited research and should be used with caution. Differences in commercial tubing from several manufacturers, including corrugation design and pipe stiffness and soil conditions, may change the assumptions; and, therefore, maximum depths may be more or less than stated above.

\* Based on 20 percent maximum deflection.

§ Any depth is permissible for this or less width and for (0.67 ft) trench width for all sizes.

Source: ASAE-EP260.4

to the drain, special care should be exercised to fill all the spaces under and around the tile or tubing with granular material.

In the ordinary bedding method, the trench bottom is shaped by the shoe of the trenching machine to provide a reasonably close fit for a width of about 50 percent of the conduit diameter. The remainder of the conduit is covered with granular material to a height of at least 0.5 feet above its top or topsoil is placed to fill all spaces under and around the drain. The present method of installing drains using trenching machines is effective, and for practical purposes ordinary bedding may be assumed. The bedding (ordinary) allows the drain to be installed in a deeper or wider trench than if no attention had been paid to the bedding of the drain.

For computation of maximum allowable loads on subsurface drains, use the trench and bedding conditions specified and the crushing strength of the kind and class of drain.

The design load on the conduit should be based on a combination of equipment loads and trench loads. Equipment loads are based on the maximum expected wheel loads for the equipment to be used, the minimum height of cover over the conduit, and the trench width. Equipment loads on the conduit may be neglected if the depth of cover exceeds 6 feet. Trench loads are based on the type of backfill over the conduit, the width of the trench, and the unit weight of the backfill material.

### (h) Size of drains

The size of drains depends upon the required flow and the grade on which they are laid. The required flow is determined from the drainage coefficient and the area or length of drains contributing flow, plus any allowances for concentrated flow entering from the surface, springs, or other sources. The contributing drainage area for a complete drainage system is about the same as the total length of all contributing lines multiplied by the spacing between such lines.

Random drains in poorly drained depressions are often used later as main drains for a more complete

drainage system. Where such expansion is likely, the additional area that such drains would serve should be included in determining the size of the initial random line. Where surface water is admitted directly into a drain by surface inlets, the entire watershed contributing to the inlet should be included. Flow from such watersheds often can be reduced by diversion ditches.

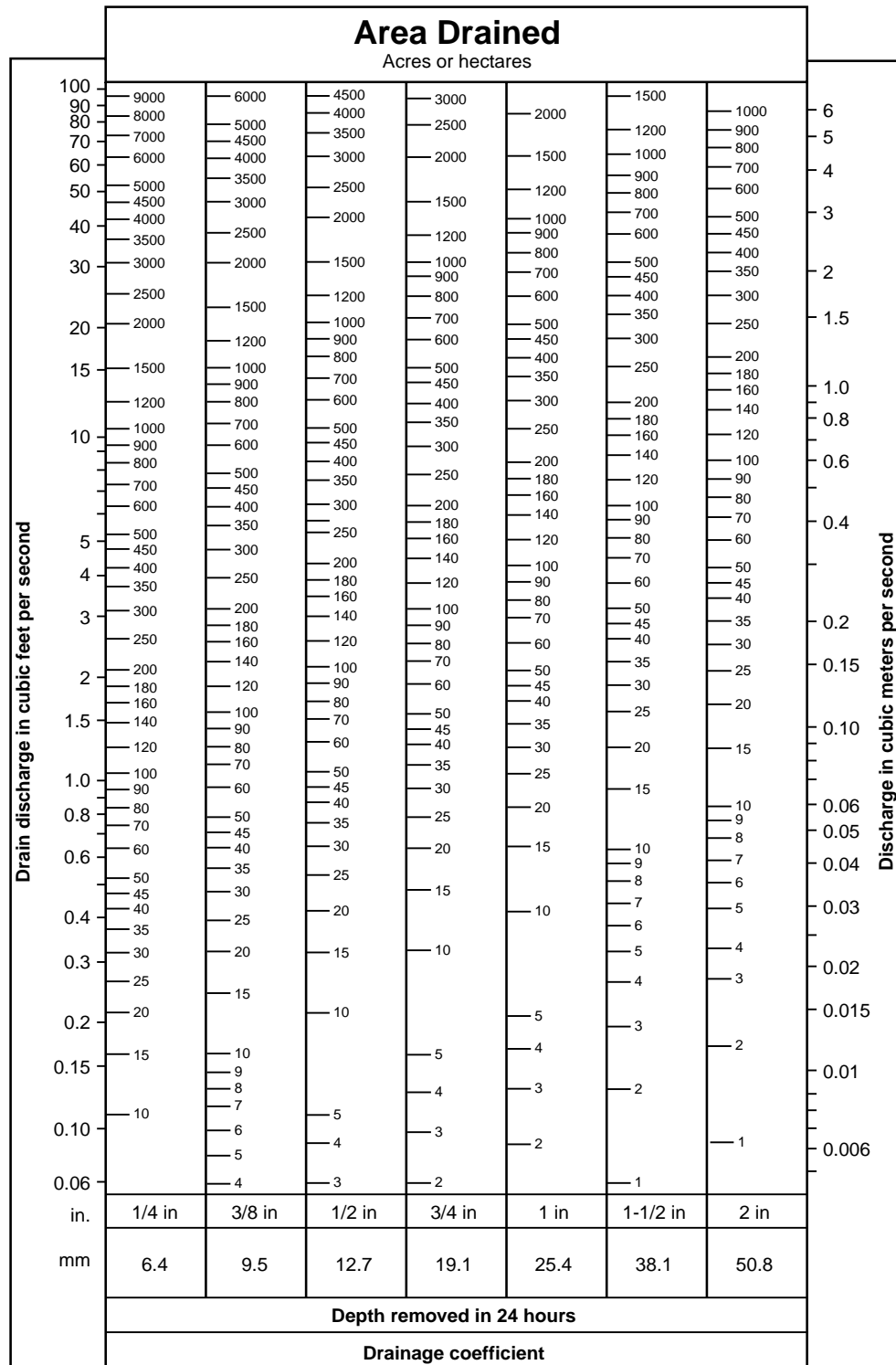
#### (1) Main drain

The required discharge can be determined using figure 14–33 for a given drainage coefficient and area (acres). The required size of the corrugated plastic drainage tubing can be determined directly from figure 14–34. After grade, coefficient, and drainage area have been determined, the size of clay or concrete drain tile required can be determined directly from the tile drainage chart in figure 14–35. The same charts may be used if the required flow and the grade of the drains are known. The size required for all types of drains can be calculated using Manning's equation with the appropriate roughness coefficients (table 14–7). The example on page 14–68 illustrates the use of these charts for the subsurface drainage system shown in figure 14–36.

**Table 14–7** Values of Manning's  $n$  for subsurface drains and conduits

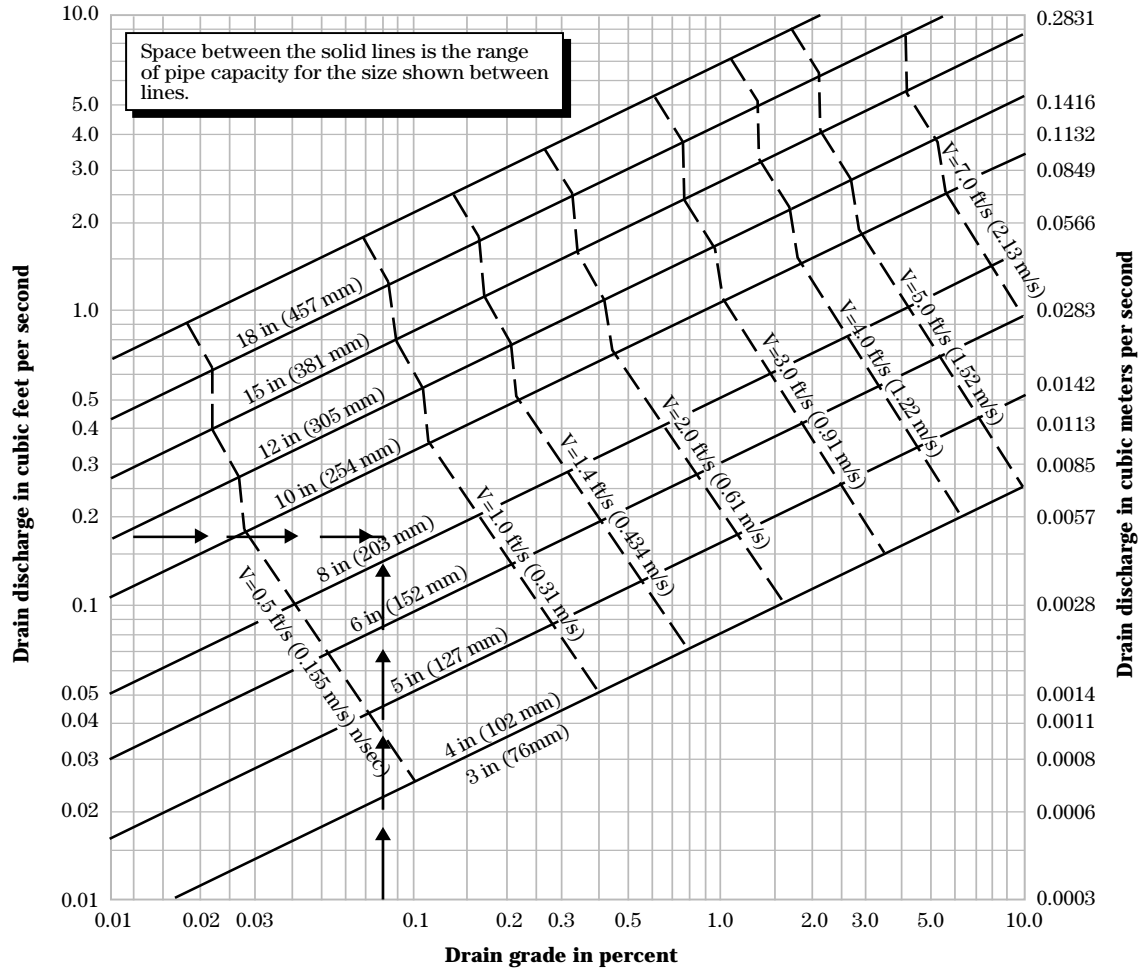
| Description of pipe          | Values of $n$ |
|------------------------------|---------------|
| Corrugated plastic tubing    |               |
| 3 to 8 inch diameter         | 0.015         |
| 10 to 12 inch diameter       | 0.017         |
| >12 inch diameter            | 0.020         |
| Smooth plastic, unperforated | 0.010 – 0.012 |
| Smooth plastic, perforated   | 0.010 – 0.012 |
| Annular corrugated metal     | 0.021 – 0.025 |
| Helical corrugated           | 0.015 – 0.020 |
| Concrete                     | 0.012 – 0.017 |
| Vitrified sewer pipe         | 0.013 – 0.015 |
| Clay drainage tile           | 0.012 – 0.014 |

**Figure 14-33** Subsurface drain discharge



Note: Use acres with ft<sup>3</sup>/s and hectares with m<sup>3</sup>/s  
(Source-ASAE Standard EP260.4)

**Figure 14-34** Determining size of corrugated plastic pipe

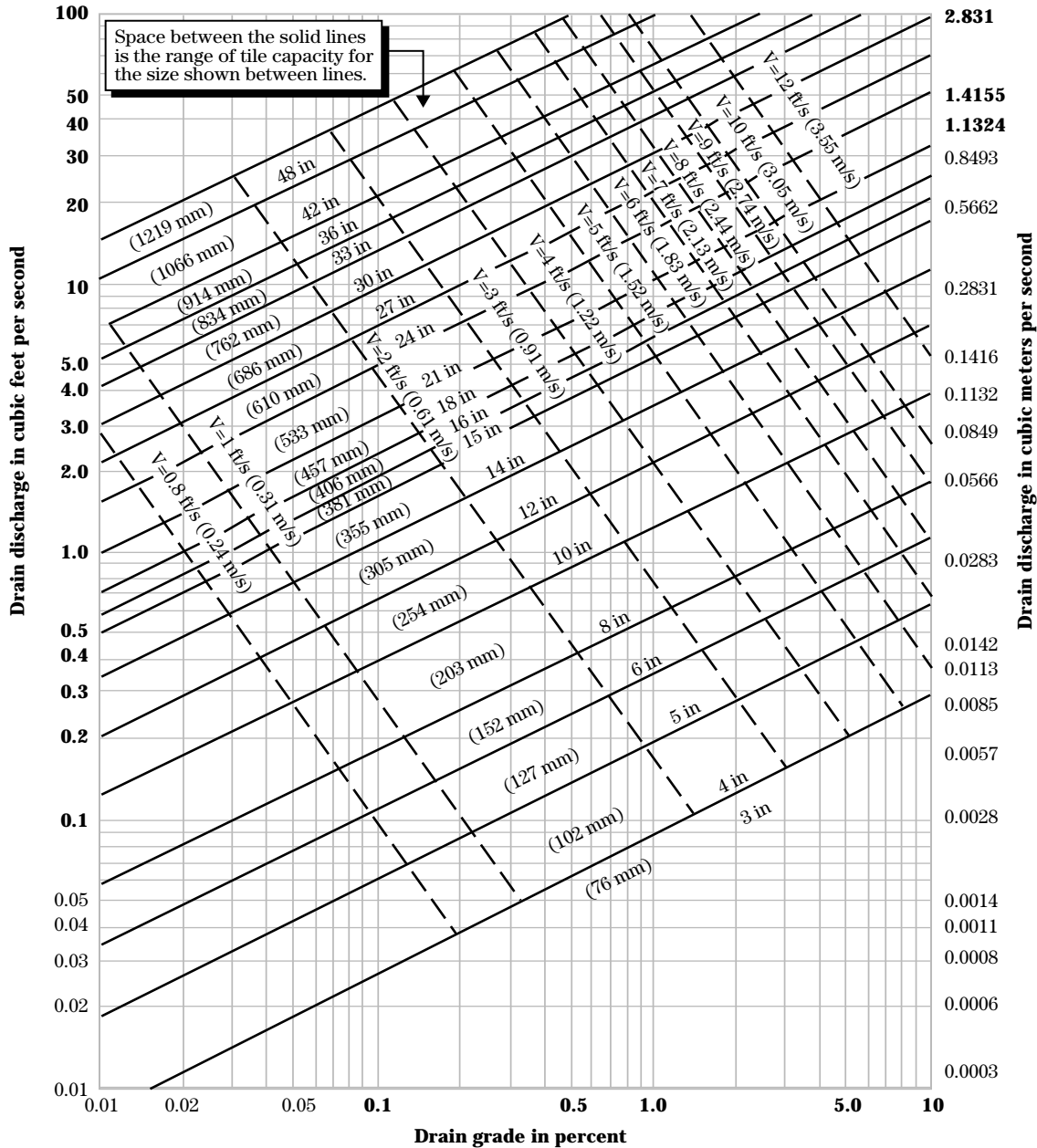


Drain grade = hydraulic gradient  
 Percent = ft per 100 ft, or m per 100 m  
 V = velocity in ft/s (m/s)

|                                      |
|--------------------------------------|
| 3 to 8 in (76 to 203 mm) : n = 0.015 |
| 10, 12 in (254, 305 mm) : n = 0.017  |
| 15, 18 in (381, 457 mm) : n = 0.02   |

(Source-ASAE Standard EP260.4)

**Figure 14-35** Determining size of clay or concrete drain tile (n = 0.013)



Drain grade = hydraulic gradient  
 (Percent = ft per 100 ft, or m per 100 m)  
 V = velocity in ft/s (m/s)  
 (Source-ASAE Standard EP260.4)

**Example for main drain** (see fig. 14–36):

**Given:**

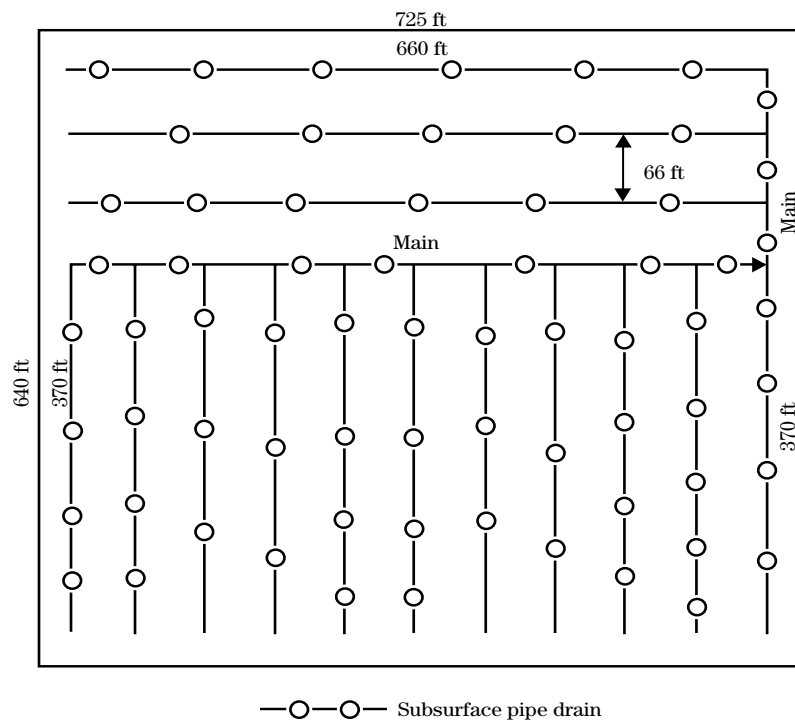
A tract of land about 640 by 725 feet is to be drained for general crops. The drainage area is 10.65 acres. The drainage coefficient is 3/8 inch in 24 hours (0.0156 inch/hour). A parallel system that has laterals spaced 66 feet apart, requires 4 lines, 660 feet long; 11 lines, 370 feet long; and 1 line, 200 feet long; making a total of 6,910 feet of drain. The main, as shown from a plotted profile, is on a grade of 0.08 percent and is to be corrugated plastic tubing.

**Required:**

Size of the corrugated plastic main at the outlet and its capacity.

Using figure 14–33, find 10.65 acres in the 3/8 inch coefficient column under Area Drained to determine the discharge of 0.17 cubic feet per second. Using this discharge, enter figure 14–34 and a slope of 0.08 vertical gradeline. The point of intersection lies within the range for an 8-inch drain. The top line of the space marked 8 represents the 8-inch drain flowing full when the hydraulic grade is the grade of the drain. From the intersection of the top of 8-inch range and grade of 0.08 percent, produce a line horizontally to intersect the vertical on the left. The drain flowing full will discharge 0.3 cubic feet per second, which shows that the drain selected will not be flowing full.

**Figure 14–36** Subsurface drainage system



**(2) Field or drain lateral**

To compute the size of a lateral, first determine the required discharge for the lateral. The following formula or figure 14-33 can be used. When the discharge is determined, use figure 14-34 to determine the drain size for plastic pipe or figure 14-35 for clay or concrete tile.

In the case of parallel drains, the area served by the drain is equal to the spacing times the length of the drain plus one-half the spacing. The discharge can be expressed by the following formula:

$$Q_r = \frac{qS \left( L + \frac{S}{2} \right)}{43,200}$$

where:

- $Q_r$  = Relief drain discharge, ft<sup>3</sup>/s
- $q$  = Drainage coefficient, in/hr
- $S$  = Drain spacing, ft
- $L$  = Drain length, ft

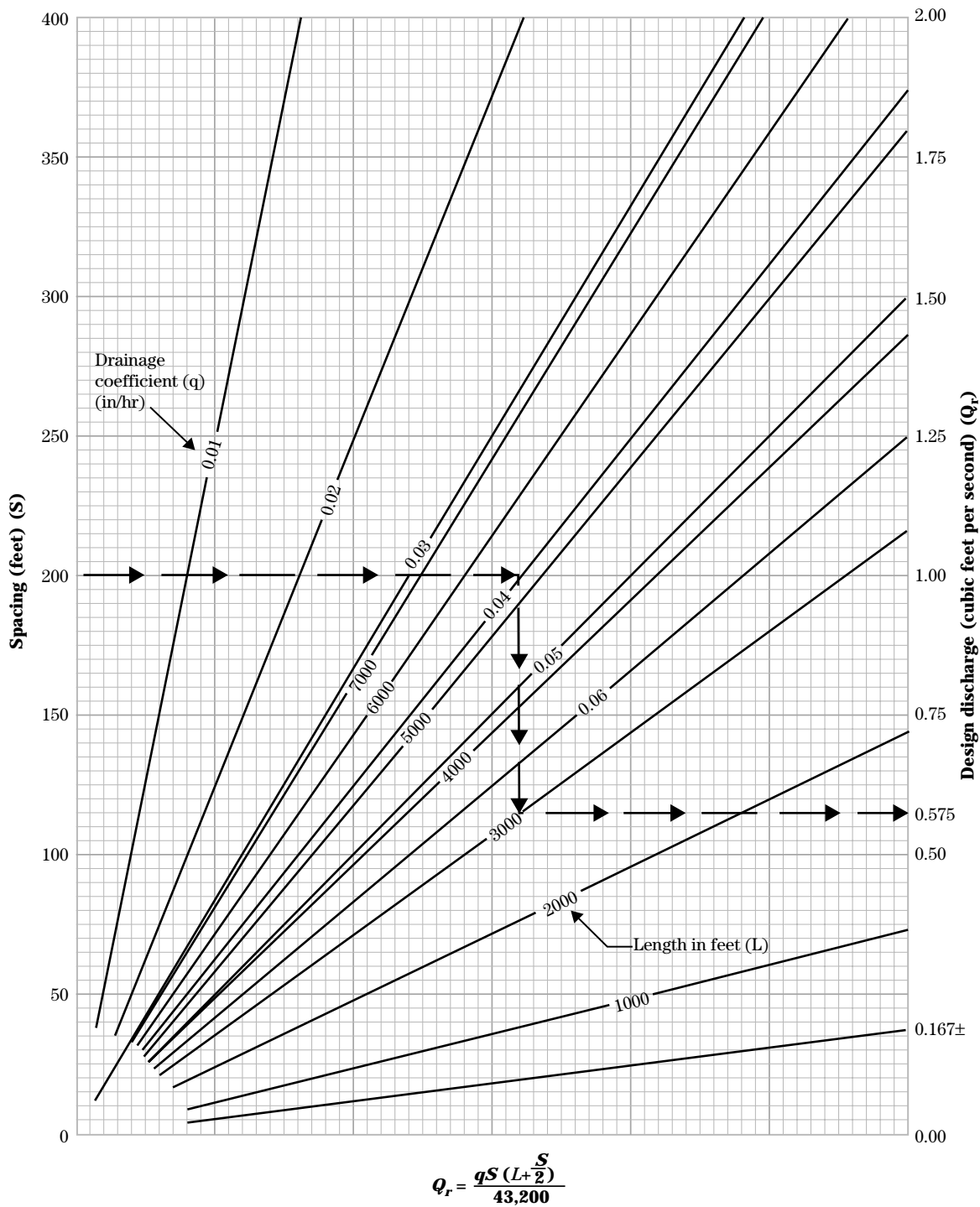
**Example:**

- Drain spacing – 200 feet (S)
- Drain length – 3,000 feet (L)
- Drain coefficient – 0.04 inches/hour (q) (1 inch/day)
- Drain grade – 0.30 percent

Using figure 14-37, find spacing of 200 feet on the vertical scale on the left; follow horizontally to the right to intersect with the drainage coefficient curve 0.04. From that point follow vertically to intersect the length curve of 3,000 feet, then go horizontally to the right to read the discharge of 0.575 cubic feet per second. Using figure 14-35 for plastic tubing, find the above discharge on the vertical scale on the left and look horizontally to intersect the grade of 0.30 percent. An 8-inch drain will be required.

The drain chart has velocity lines. In the example, the velocity in the drain is between 1.4 and 2.0 feet per second, thus, minimizing sediment accumulation. In a drainage system, different sizes of drains may be needed. Required drain size may change at breaks in grade and changes in tributary area.

**Figure 14-37** Curves to determine discharge,  $Q_r$ , for main drain





## 650.1424 Drain envelopes

Drain envelope is used here as a generic term that includes any type of material placed on or around a subsurface drain for one or more of the following reasons:

- To stabilize the soil structure of the surrounding soil material, more specifically a filter envelope.
- To improve flow conditions in the immediate vicinity of the drain, more specifically a hydraulic envelope.
- To provide a structural bedding for the drain, also referred to as bedding.

Refer to the glossary for more complete definitions of envelopes (hydraulic envelope, filter envelope, and bedding).

Soils in which drains are prone to mineral clogging are commonly referred to as problem soils because the soil particles tend to migrate into the drain. In practice, all very fine sandy or silty soils with low clay content are probable problem soils. Finer textured soils, even with high clay content if the soil is considered dispersed, may present clogging problems in addition to being difficult to drain. Envelope materials placed around subsurface drains (drain envelopes) have both hydraulic and mechanical functions (Dierickx 1992). The protection and stabilizing of the surrounding soil material should be the planned objective as it is not the filter envelope that fails, but the structure of the surrounding soil (Stuyt 1992b). More complete information on drain envelopes is in the Urban Subsurface Drainage Manual (ASCE 1998).

### (a) Drain envelope materials

Drain envelope materials used to protect subsurface drains include almost all permeable porous materials that are economically available in large quantities. Based on the composition of the substances used, they can be divided into three general categories: mineral, organic, and geotextile envelope materials. Mineral envelopes consist of coarse sand, fine gravel, and glass fiber membranes that are applied while installing the drain pipe. Organic envelopes include prewrapped loose plant materials, fibers, chips, or granules. Synthetic materials are geotextile fabrics specifically

manufactured for use in drainage and soil stabilization. Drain envelope materials are most effective when placed completely around the pipe. General drain envelope recommendations are summarized in figure 14–38.

The practice of blinding or covering subsurface drains with a layer of topsoil before backfilling the trench actually provides many humid area drains with permeable envelope material. Humid area surface soils tend to have a well developed, stable, and permeable structure that functions well as a drain envelope. In stratified soils, drains are blinded by shaving the coarsest textured materials in the soil profile down over the pipe.

### (1) Sand-gravel

Traditionally, the most common and widely used drain envelope that also satisfies the definition of filter envelope material is graded coarse sand and fine gravel. The envelope material may be pit run coarse sand and fine gravel containing a minimum of fines. Properly designed or selected sand-gravel drain envelopes can fulfill all the mechanical, soil stabilizing, and hydraulic functions of a filter envelope. Figure 14–39 shows typical bedding or sand-gravel envelope installations. One example uses an impermeable sheet or geotextile filter. This is used to reduce costs where sand and gravel envelope materials are expensive.

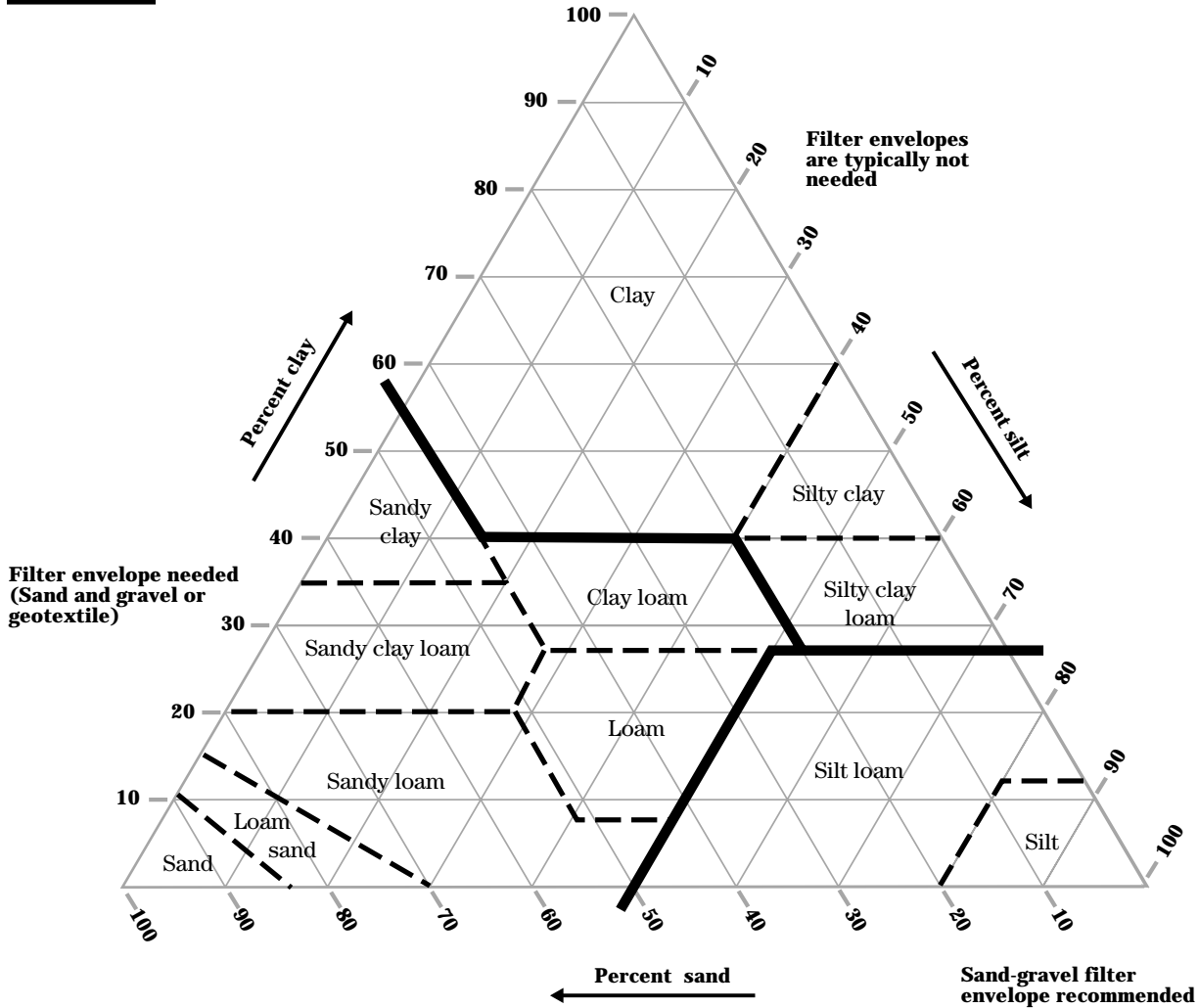
### (2) Organic material

The service life and suitability of organic materials as drain envelopes for subsurface drains cannot be predicted with certainty. Organic matter placed as a drain envelope may also affect chemical reactions in the soil that result in biochemical clogging problems. Where ochre clogging of drains is expected, organic matter should be used with caution.

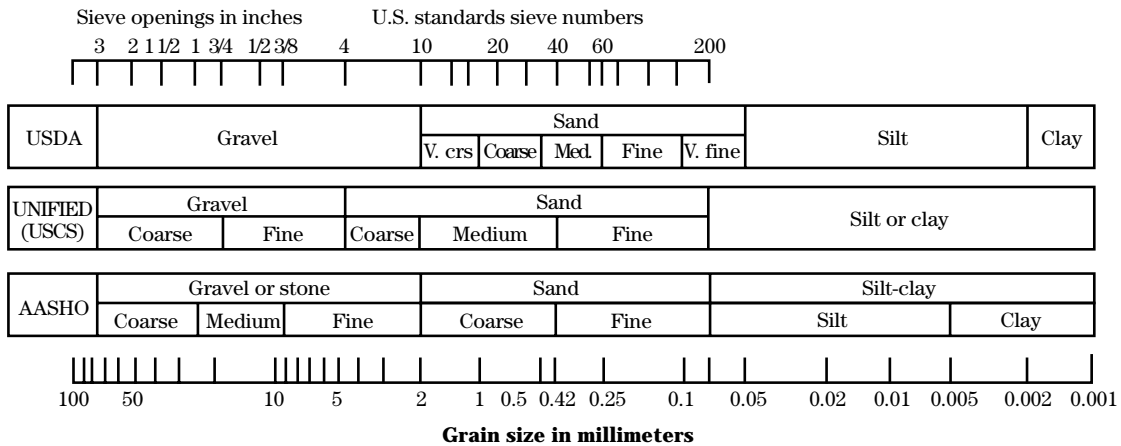
### (3) Synthetic fiber materials

In the United States during the 1970's, several dozen installations of thin filter envelopes of fiberglass and spun bonded nylon were monitored with the assistance of the NRCS (SCS at that time). The drain systems typically used 4-inch (100 mm) corrugated polyethylene tubing (CPE). The fiberglass membrane used in these installations did not successfully span the corrugations of the tubing while the spun bonded nylon did. As a result the fabricator of fiberglass adopted the use of spun bonded nylon. Figure 14–38 was issued to the field offices at that time to provide

**Figure 14-38** Filter envelope recommendation relative to soil texture (source USDA)



**Comparison of particle size scales**



guidance on the application of the two major types of filter envelopes, which were sand and gravel or thin spun bonded nylon. The figure has been updated to reflect recommendations for geotextiles rather than just nylon.

**(4) Prewrapped loose materials**

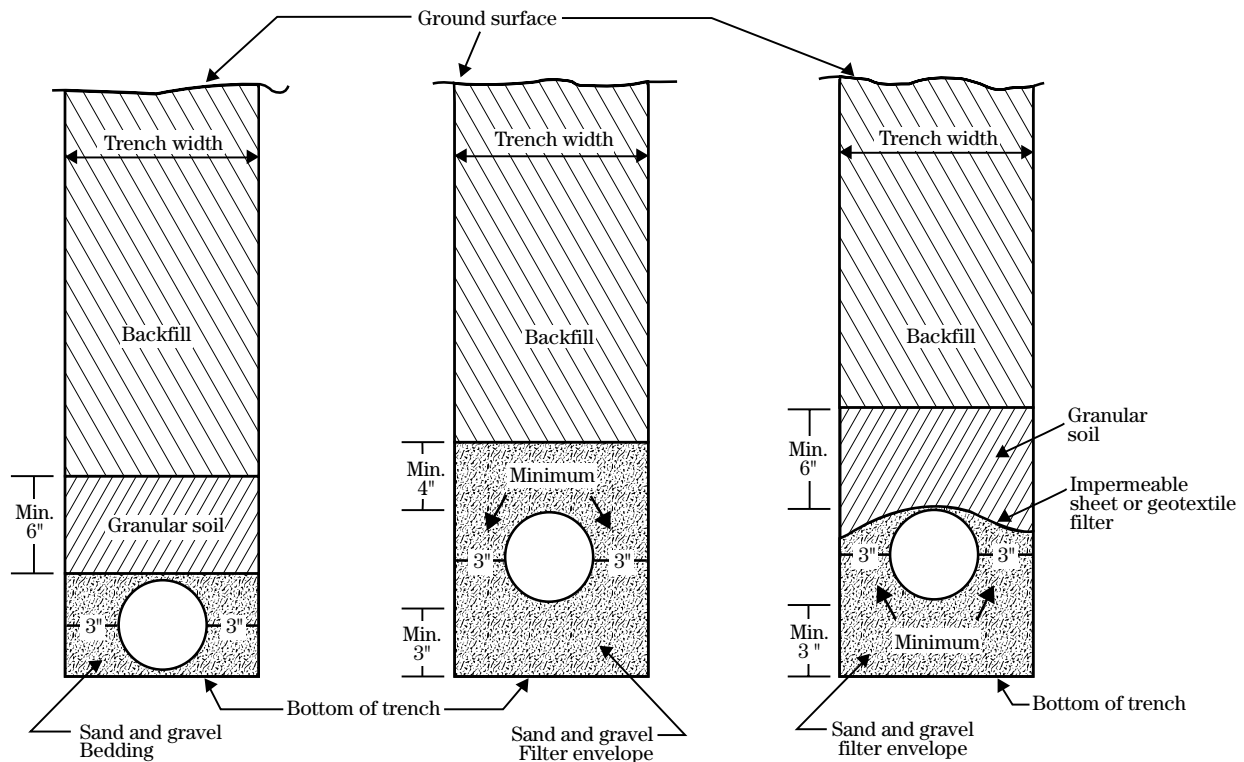
Prewrapped loose materials (PLM) used for drain envelopes have a permeable structure consisting of loose, randomly oriented yarns, fibers, filaments, grains, granules, or beads surrounding a corrugated plastic drain pipe. These materials are assembled with the pipe at the time of manufacture as a permeable hydraulic envelope of uniform thickness held in place by twines or netting. The voluminous materials involved are either organic or geotextile.

**(5) Prewrapped geotextiles**

A geotextile is a permeable, polymeric material that may be woven, nonwoven, or knitted. Materials known as geotextiles are widely used as pre-wrapped synthetic drain envelopes. Geotextiles are made of polyester, polypropylene, polyamide, polystyrene, and nylon.

Geotextiles differ widely in fiber size or weight, smoothness, and weave density. No single geotextile is suitable as a drain envelope for all problem soils. The materials vary in weight, opening size, fiber diameter, thickness, and uniformity. The geotextiles are commonly wrapped on the corrugated plastic drain pipe in the production plant. The finished product must be sufficiently strong to withstand normal handling that is part of the construction and installation process.

**Figure 14-39** Typical bedding or envelope installations



## (b) Principles of drain envelope design

### (1) Exit gradients in soil near drains

As water approaches a subsurface drain, the flow velocity increases as a result of flow convergence. The increased velocity is related to an increase in hydraulic gradient. The hydraulic gradient close to the drain may exceed unity resulting in soil instability. Using a gravel drain envelope increases the apparent diameter of the drain and, therefore, substantially decreases the exit gradient at the soil and drain envelope interface. A major reason for using a filter envelope is to reduce the hydraulic gradient at the soil and envelope interface, which acts to stabilize the soil in the proximity of the drain system.

### (2) Hydraulic failure gradient

The hydraulic failure gradient is the change in hydraulic head per unit distance that results in soil instability, generally a gradient exceeding unity. As long as the flow rate (and the associated hydraulic gradient) in a soil is low, no soil particle movement occurs. If the velocity of waterflow through the soil toward drains is kept below the hydraulic failure gradient, no failure of the drain and drain envelope system should occur.

To reduce the hydraulic gradients in the soil near the drain:

1. Increase the effective diameter of the drain by using a hydraulic envelope (i.e., gravel).
2. Increase the perforation area of the drain.
3. Reduce the drain depth and spacing to decrease the possible magnitude of the gradient.
4. Use a geotextile having innerflow characteristics to make the full surface of the corrugated drain pipe permeable. If the geotextile does not have innerflow characteristics, perforations in every corrugation should be required (Willardson and Walker 1979, Salem and Willardson 1992).

If a soil has a high hydraulic failure gradient, a drain envelope may not be necessary. Many humid area soils do not require use of a drain envelope. If the drain tubes have an opening or perforation area from 1 to 2.5 square inches per foot, the drain functions well without sedimentation problems in structurally stable soils. In some areas, criteria based on the soil clay content and type is used to determine whether a filter envelope is required. Such criteria are based on local experience and field observations.

## (c) Design of drain envelopes

### (1) Sand-gravel filter envelope design

The general procedure for designing a sand-gravel filter envelope for a given soil is:

- Make a mechanical analyses of both the soil and the proposed filter envelope material.
- Compare the two particle size distribution curves.
- Use criteria to determine whether the filter envelope material is satisfactory.

The criteria include:

- The  $D_{15}$  (defined below) size of the filter material should be at least 4 times the diameter of the  $d_{15}$  of the base material. (This would make the filter material roughly more than 10 times more permeable as the base material.)
- The  $D_{15}$  of filter material should not be more than 4 times larger than the  $d_{85}$  of the base material. (This prevents the fine particles of the base material from washing through the filter material.)

The following gradation limits are recommended:

- Upper limit of  $D_{100}$  is 38 mm (1.5 inches).
- Upper limit of  $D_{15}$  is the larger of 7 times  $d_{85}$  or 0.6 mm.
- Lower limit of  $D_{15}$  is the larger of 4 times  $d_{15}$  or 0.2 mm.
- Lower limit of  $D_5$  is 0.075 mm (number 200 sieve).

$D_{100}$  represents the particle size in the filter material for which 100 percent, by weight, of the soil particles are finer (similarly for  $D_{15}$  and  $D_5$ ). The  $d_{85}$  and  $d_{15}$  represent the particle size in the surrounding base material for which 85 percent and 15 percent, by weight, of the soil particles are finer. In the case of drainage, the base material is the soil.

Procedures for determining filter gradation design limits are found in NEH, Part 633, Chapter 26, Gradation Design of Sand and Gravel Filters.

Research on filter envelopes show that:

- If a filter envelope does not fail with the initial flow of water, it is probably permanently safe.
- The size ratios are critical.
- Materials with a  $D_{15}/d_{85}$  ratio greater than nine always fail.

- Well graded materials are more successful than uniform sized materials.
- A well-graded gravelly sand is an excellent filter or filter envelope for very uniform silt or fine uniform sand.
- It is not necessary for the grading curve of the filter envelope to be roughly the same shape as the grading curve of the soil.

### (2) Sand-gravel hydraulic envelope design

The criteria for a sand-gravel hydraulic envelope is less restrictive than for a sand-gravel filter envelope as follows:

- Upper limit of  $D_{100}$  is 38 mm (1.5 inches).
- Upper limit of  $D_{30}$  is 0.25 mm (number 60 sieve).
- Lower limit of  $D_5$  is 0.075 mm (number 200 sieve).

Pit run coarse sand and fine gravel containing a minimum of fines often meet this criteria.

Sand gradations used for concrete as specified by ASTM C-33 (fine aggregate) or AASHTO M 6-65 will satisfy these hydraulic envelope criteria and will meet the filter envelope requirements for most soils.

### (3) Geotextile filter envelope design

In filter envelope applications, the geotextile must physically survive installation, allow adequate flow of water, and basically retain the soil on its hydraulically upstream side. Both adequate flow capacity (requiring an open geotextile structure) and soil retention (requiring a tight geotextile structure) are required simultaneously. Therefore, critical geotextile parameters for filter envelope applications are permittivity, survivability, and soil retention.

**Permittivity**—Unrestricted flow of water through the geotextile is essential. Therefore, the flow capacity (permittivity) of the geotextile should be much greater than the flow capacity of the soil, typically 10 times greater or more. Permittivity values in excess of 1 unit per second ( $\text{ft}^3/\text{ft} \times \text{ft}^2 \times \text{sec}$ ) are typically required and are determined according to ASTM D 4491 (1992). Permittivity, not permeability, should be specified because permeability measures the rate at which water will pass through the geotextile under a given head without regard to geotextile thickness.

**Survivability**—The geotextile must survive installation without being damaged. AASHTO Designation M288-90 (1990) includes recommendations on minimum physical strength properties for geotextile survivability.

**Soil retention**—The geotextile must prevent excessive loss of fines (soil piping) from the upstream side. This is accomplished by checking the coarser soil particles, which in turn retain the finer soil particles. Numerous approaches can accomplish soil retention, all of which use the soil particle grading characteristics and compare them to the apparent opening size (AOS) of the geotextile. AOS is the approximate largest particle that will effectively pass through a geotextile and is determined by glass ball dry sieving (ASTM D 4751). Both AOS and  $O_{95}$ , effective opening size of the envelope pore, represent the apparent opening size in millimeters (mm) or sieve size.

The simplest method uses the percentage of fines (soil passing the No. 200 sieve). AASHTO Designation M 288-90 recommends the following retention criteria:

- Soil  $\leq 50\%$  passing the No. 200 sieve  
AOS of the geotextile No. 30 sieve  
( $O_{95} < 0.59$  mm)
- Soil  $> 50\%$  passing the No. 200 sieve  
AOS of the geotextile No. 50 sieve  
( $O_{95} < 0.297$  mm)

These criteria should meet most drainage requirements.

For more critical applications, table 14–8 recommends  $O_{95}$  values based on relative density ( $D^R$ ), coefficient of uniformity (CU), and average particle size ( $d_{50}$ ). The terms are defined as:

$d_{50}$  = soil particle size corresponding to 50% finer  
 CU = coefficient of uniformity =  $d_{60}/d_{10}$   
 $d_{60}$  = soil particle size corresponding to 60% finer  
 $d_{10}$  = soil particle size corresponding to 10% finer  
 AOS =  $O_{95}$  apparent opening size of geotextile expressed in millimeters or sieve size

Because the three approaches are restrictive in different degrees, choose one of the three approaches in table 14–8 (Koener 1986) based on the critical nature of the application.

**Clogging**—Once the geotextile is designed, the next question is “Will it clog?” Obviously, some soil particles will embed themselves within the geotextile structure; therefore, the question really is if the geotextile will completely clog such that the liquid flow through it will be shut off before the soil matrix stabilizes. Laboratory tests, such as the Gradient Ratio Test given in ASTM D 5101, are available to answer this question.

Another approach is to simply avoid situations known to lead to severe clogging problems. Three conditions are necessary for a high likelihood of complete geotextile clogging (Koerner 1986):

- cohesionless sands and silts
- gap graded particle size distribution
- high hydraulic gradients

If these three conditions are present, use of geotextiles should be avoided. A gravel or sand gravel filter envelope can be used.

#### (4) Prewrapped loose material filter envelope design

Subsurface drain filter envelopes using prewrapped loose materials may be characterized by pore size distribution, filter thickness, and hydraulic conductivity. Filter thickness and pore size distribution are determined for a natural, compressed condition, but for prewrapped loose materials, the hydraulic conductivity is generally so high that it has no bearing on selection of a filter envelope.

Retention criterion defines the capability of a filter envelope to retain soil particles and is expressed as a ratio of a characteristic pore opening size of the filter envelope to a particle size of the soil granular material

in contact with the envelope. The characteristic pore opening size of the envelope material is the  $O_{90}$  value.

Depending on the pore size index  $O_{90}$ , prewrapped loose materials are classed into three groups, with recommendations as follows:

| Label      | Class      | Pore size index range                      |
|------------|------------|--|
| PLM-XF: XF | extra fine | $0.1 \text{ mm} < O_{90}$                  |
| PLM-F: F   | fine       | $0.3 \text{ mm} < O_{90} < 0.6 \text{ mm}$ |
| PLM-S: S   | standard   | $0.6 \text{ mm} < O_{90} < 1.1 \text{ mm}$ |

Coil ends are labeled with tape imprinted with identification PLM-XF, PLM-F, or PLM-S.

Minimum thickness is required to guarantee a homogeneous filter envelope. In addition to these  $O_{90}$  ranges, the following minimum filter envelope thicknesses are required regardless of the  $O_{90}$  range involved.

| Material            | Minimum filter envelope thickness         |
|---------------------|---|
| synthetic, fibrous  | 3 mm (e.g., poly-propylene fibers)        |
| synthetic, granular | 8 mm (e.g., polystyrene beads)            |
| organic, fibrous    | 4 mm (e.g., coconut fibers)               |
| organic granular    | not yet fixed (e.g., wood chips, sawdust) |

#### (5) Combination gravel and geotextile filter envelope design

Properly graded gravel or sand gravel material needed for a satisfactory filter envelope may not be readily available, or the cost of handling, including transportation, may be prohibitive. Also the soil material in the proximity of the subsurface drain may be either difficult or impossible to stabilize with economically available geotextile materials alone. The opportunity

**Table 14-8** Relationships used to obtain fabric opening size to protect against excessive loss of fines during filtration (source: Giuard 1982)

| Relative density of base material    | $1 < CU < 3$               | $CU > 3$                   |
|--------------------------------------|----------------------------|----------------------------|
| Loose ( $D^R < 50\%$ )               | $O_{95} < (CU)(d_{50})$    | $O_{95} < (9d_{50})/CU$    |
| Intermediate ( $50\% < D^R < 80\%$ ) | $O_{95} < 1.5(CU)(d_{50})$ | $O_{95} < (13.5d_{50})/CU$ |
| Dense ( $D^R > 80\%$ )               | $O_{95} < 2(CU)(d_{50})$   | $O_{95} < (18d_{50})/CU$   |

to use gravel and geotextile material together for a practical and economic filter envelope should be considered. On many sites the most feasible filter envelope can be designed and constructed from a readily available pit run sand or gravel that would not be satisfactory alone, but can be used along with an economical geotextile to satisfy the filter envelope design requirements.

A common application incorporates a thin geotextile material adjacent to the pipe with the pit run sand or gap graded gravel surrounding the geotextile. The combination system should be designed using the appropriate criteria given above for each of the filter envelope materials acting independently, resulting in two filter envelopes working in unison. The geotextile is designed to retain the sand or gravel envelope material. The thickness of the sand or gravel envelope should be designed to increase the effective radius of the combination drain envelope to the point that the resulting hydraulic gradient in the soil adjacent to the envelope is reduced satisfactorily.

The configuration may be reversed with the geotextile outside the gravel envelope and adjacent to the soil being protected. For this combination the gravel should be coarse enough that migration to or into the pipe is not a concern. The key factor is to increase the area of the geotextile in contact with the soil to satisfactorily reduce the flow velocity associated with the exit gradient. This configuration uses more geotextile per linear length of drain than the combination having the geotextile adjacent to the pipe, but in confined areas it may be the most cost effective.

## 650.1425 Materials

Common subsurface drainpipe materials include plastic, concrete, metal, and clay. Standards are continually updated by standards organizations, such as ASTM and AASHTO, so pipe materials meeting recognized standards adopted by these types of organizations should always be used. Current standards that can be considered follow.

### (a) Concrete pipe

Reinforced and nonreinforced concrete pipes are used for gravity flow systems. Concrete fittings and appurtenances, such as wyes, tees, and manhole sections, are generally available. A number of jointing methods are available depending on the tightness required. Concrete pipe is specified by diameter, type of joint, and D-load strength or reinforcement requirements.

The product should be manufactured in accordance with one or more of the following standard specifications:

**ASTM C14/AASHTO M86 (ASTM C14M/AASHTO M86M)**—Concrete Sewer, Storm Drain and Culvert Pipe. These specifications cover nonreinforced concrete pipe from 4- through 36-inch (100 through 900 mm) diameters in Class 1, 2, and 3 strengths.

**ASTM C76/AASHTO M170 (ASTM C76M/AASHTO M170M)**—Reinforced Concrete Culvert, Storm Drain, and Sewer Pipe. These specifications cover reinforced concrete pipe in five standard strengths: Class I in 60- through 144-inch diameters, and Class II, III, IV, and V in 12- through 144-inch (300 through 3,600 mm) diameters.

**ASTM C118 (ASTM C118M)**—Concrete Pipe for Irrigation or Drainage. These specifications cover concrete pipe to be used for the conveyance of water under low hydrostatic heads, generally not exceeding 25 feet (75 kPa), and for drainage in sizes from 4- through 24-inch (100 through 600 mm) diameters in standard and heavy-duty strengths.

**ASTM C361 (ASTM C361M)**—Reinforced Concrete Low-Head Pressure Pipe. These specifications cover reinforced concrete pipe with low internal hydrostatic heads generally not exceeding 125 feet (375 kPa) in sizes from 12- through 108-inch (100 through 2700 mm) diameters.

**ASTM C412/AASHTO M178 (ASTM C412M/AASHTO M178M)**—Concrete Drain Tile. These specifications cover nonreinforced concrete drain tile with internal diameters from 4 through 24 inches (100 through 600 mm) for standard quality and 4 through 36 inches (100 through 900 mm) for extra-quality, heavy-duty extra-quality, and special quality concrete drain tile.

**ASTM C444/AASHTO M175 (ASTM C444M/AASHTO M175M)**—Perforated Concrete Pipe. These specifications cover perforated concrete pipe intended to be used for underdrainage in 4-inch (100 mm) and larger diameters.

**ASTM C505 (ASTM C505M)**—Nonreinforced Concrete Irrigation Pipe with Rubber Gasket Joints. These specifications cover pipe to be used for the conveyance of water with working pressures up to 30 feet (90 kPa) of head.

**ASTM C506/AASHTO M206 (ASTM C506M/AASHTO M206M)**—Reinforced Concrete Arch Culvert, Storm Drain, and Sewer Pipe. These specifications cover reinforced concrete arch pipe in sizes from 15- through 132-inch (375 through 3,300 mm) equivalent circular diameters.

**ASTM C507/AASHTO M207 (ASTM C507M/AASHTO M207M)**—Reinforced Concrete Elliptical Culvert, Storm Drain, and Sewer Pipe. These specifications cover reinforced elliptical concrete pipe in five standard classes of horizontal elliptical. 18- through 144-inch (450 through 3,600 mm) in equivalent circular diameter, and five standard classes of vertical elliptical, 36- through 144-inch (900 through 3,600 mm) in equivalent circular diameter.

**ASTM C654/AASHTO M176 (ASTM C654M/AASHTO M176M)**—Porous Concrete Pipe. These specifications cover porous nonreinforced concrete pipe in sizes from 4- through 24-inch (100 through 600 mm) diameters and in two strength classes.

**ASTM C655/AASHTO M242 (ASTM C655M/AASHTO M242M)**—Reinforced Concrete D-Load Culvert, Storm Drain, and Sewer Pipe. These specifications cover acceptance of pipe design and production based on the D-load concept and statistical sampling techniques.

**ASTM C789/AASHTO M259 (ASTM C789M/AASHTO M259M)**—Precast Reinforced Concrete Box Sections for Culverts, Storm Drains, and Sewers. These specifications cover precast reinforced concrete box sections from 3-foot (900 mm) span by 2-foot (600 mm) rise to 12-foot (3,600 mm) span by 12-foot (3,600 mm) rise.

**ASTM C850/AASHTO M273 (ASTM C850M/AASHTO M273M)**—Precast Reinforced Concrete Box Sections for Culverts, Storm Drains, and Sewers with less than 2 feet (0.6 m) of Cover Subject to Highway Loading. These specifications cover box sections with less than 2 feet (0.6 m) of earth cover in sizes from 3-foot (900 mm) span by 2-foot (600 mm) rise to 12-foot span (3600 mm) by 12-foot (3600 mm) rise.

**ASTM C985 (ASTM C985M)**—Nonreinforced Concrete Specified Strength Culvert, Storm Drain, and Sewer Pipe. These specifications cover acceptance of nonreinforced concrete pipe design and production based on specified strengths and statistical sampling techniques.

## (b) Thermoplastic pipe

Thermoplastic pipe materials include high density polyethylene (HDPE), poly (vinyl) chloride (PVC), and acrylonitrile-butadiene-styrene (ABS). Thermoplastic pipes are produced in a variety of shapes and dimensions.

**(1) High density polyethylene (HDPE) pipe**  
HDPE pipe is available for gravity and low-pressure flow systems. The application will dictate the quality of the joining system used. Fittings are widely available and can be adapted to many other products. HDPE pipe should be manufactured according to one or more of the following standard specifications:

**AASHTO M252**—Corrugated Polyethylene Drainage Tubing. This specification covers corrugated polyethylene tubing from 3- through 10-inch diameter (75



through 250 mm), couplings, and fittings for use in surface and subsurface drainage applications. Provisions are included for corrugated and smooth interior pipe.

**AASHTO M294**—Corrugated Polyethylene Pipe, 12- to 48-inch Diameter. This specification covers the requirements of corrugated polyethylene pipe, couplings, and fittings for use in storm sewers and subsurface drainage systems. Provisions are included for both corrugated and smooth interior pipe.

**AASHTO MP7-95**—Corrugated Polyethylene Pipe 54 and 60-inch Diameter. This specification covers the requirements of corrugated polyethylene pipe, couplings, and fittings for use in storm sewers and subsurface drainage systems. Provisions are included for smooth interior pipe.

**ASTM F405**—Corrugated Polyethylene Pipe and Fittings. This specification covers pipe with 3- through 6-inch (75 through 150 mm) diameter. This product is commonly used for subsurface and surface drainage installations.

**ASTM F667**—Large Diameter Corrugated Polyethylene Pipe and Fittings. This specification covers pipes from 8- through 24-inch (200 through 600 mm) diameters commonly used for surface and subsurface drainage.

**ASTM F810**—Smoothwall Polyethylene (PE) Pipe for Use in Drainage and Waste Disposal Absorption Fields. This specification covers smoothwall HDPE pipe, including co-extruded, perforated and nonperforated, from 3- through 6-inch (75 through 150 mm) diameter.

**ASTM F892**—Polyethylene (PE) Corrugated Pipe With a Smooth Interior and Fittings. This specification covers corrugated PE pipe 4 inches (100 mm) in diameter.

**ASTM F894**—Polyethylene (PE) Large Diameter Profile Wall Sewer and Drain Pipe. The specification covers profile wall PE pipe from 18- to 120-inch (450 to 3,000 mm) diameter for low pressure and gravity flow applications.

## **(2) Polyvinyl chloride (PVC) pipe**

PVC pipe is used for gravity and low pressure flow systems. PVC composite pipe is a combination of a PVC pipe with a series of truss annuli. It is filled with lightweight portland cement concrete or other such material. PVC fittings are widely available. PVC pipe should be manufactured in accordance with one or more of the following standard specifications:

**AASHTO M304**—Poly (Vinyl Chloride) (PVC) Ribbed Drain Pipe and Fittings Based on Controlled Inside Diameter. This specification covers 18- to 48-inch diameter ribbed PVC pipe.

**ASTM D2680/AASHTO M264**—Acrylonitrile-Butadiene-Styrene (ABS) and Poly (Vinyl Chloride) (PVC) Composite Sewer Piping. These specifications cover ABS or PVC composite pipe, fittings, and a joining system for storm drain systems in 6- through 15-inch (150 through 375 mm) diameter.

**ASTM D2729**—Poly (Vinyl Chloride) (PVC) Sewer Pipe and Fittings. This specification covers PVC pipe and fittings for sewer and drain pipe from 2-inch (50 mm) to 6-inch (150 mm) diameters.

**ASTM D3034**—Type PSM Poly (Vinyl Chloride) (PVC) Sewer Pipe and Fittings. This specification covers PVC pipe and fittings from 4- through 15-inch (100 to 375 mm) diameters.

**ASTM F679**—Poly (Vinyl Chloride) (PVC) Large-Diameter Plastic Gravity Sewer Pipe and Fittings. This specification covers PVC gravity sewer pipe and fittings from 18- through 36-inch (450 through 900 mm) diameters with integral bell elastomeric seal joints and smooth inner walls.

**ASTM F758**—Smooth-Wall Poly (Vinyl Chloride) (PVC) Plastic Underdrain Systems for Highways, Airports, and Similar Drainage. This specification covers PVC pipe and fittings for underdrains from 4- through 8-inch (100 through 200 mm) diameters with perforated or nonperforated walls for use in subsurface drainage systems.

**ASTM F789**—Type PS-46 Poly (Vinyl Chloride) (PVC) Plastic Gravity Flow Sewer Pipe and Fittings. This specification covers requirements for PVC gravity sewer pipe and fittings from 4- through 18-inch (100 through 450 mm) diameters.

**ASTM F794**—Poly (Vinyl Chloride) (PVC) Profile Gravity Sewer Pipe and Fittings Based on Controlled Inside Diameter. This specification covers PVC pipe and fittings from 4 through 48 inches (200 through 1200 mm) with integral bell and elastomeric seal joints.

**ASTM F949**—Poly (Vinyl Chloride) (PVC) Corrugated Sewer Pipe With a Smooth Interior and Fittings. This specification gives requirements for PVC pipe and fittings from 4 through 36-inch (100 through 900 mm) diameters with corrugated outer wall and smooth inner wall.

### (3) Acrylonitrile-butadiene-styrene (ABS) pipe and ABS composite pipe

ABS and ABS composite pipe should be manufactured in accordance with one of the following standard specifications:

**ASTM D2680/AASHTO M264**—Acrylonitrile-Butadiene-Styrene (ABS) and Poly (Vinyl Chloride) (PVC) Composite Sewer Piping. These specifications cover ABS or PVC composite pipe, fittings, and a joining system for 4- to 15-inch (100 to 375 mm) diameter.

**ASTM D2751**—Acrylonitrile-Butadiene-Styrene (ABS) Sewer Pipe and Fittings. This specification covers ABS pipe and fittings from 3- through 12-inch (75 through 300 mm) diameter.

### (c) Metal pipe

Corrugated metal pipe is fabricated from corrugated steel or aluminum sheets or coils. Corrugated metal pipe is specified by size, shape, wall profile, gauge or wall thickness, and coating or lining. Appurtenances including tees, wyes, elbows, and manholes are available. Corrugated metal pipe should be manufactured in accordance with one or more of the following standard specifications:

**AASHTO M190**—Bituminous Coated Corrugated Metal Culvert Pipe. This specification covers characteristics of bituminous coated corrugated metal and pipe arches meeting AASHTO M36.

**ASTM A760/AASHTO M36**—Corrugated Steel Pipe, Metallic-Coated for Sewers and Drains. These specifications cover metallic-coated corrugated steel pipe from 4- through 144-inch (100 to 3600 mm) diameter.

**ASTM A762/AASHTO M245**—Corrugated Steel Pipe, Polymer Precoated for Sewers and Drains. These specifications cover polymer precoated corrugated steel pipe from 4- through 144-inch (100 through 3600 mm) diameter.

**ASTM B745/AASHTO M196**—Corrugated Aluminum Pipe for Sewers and Drains. These specifications cover corrugated aluminum pipe from 4- through 144-inch (100 through 3600 mm) diameter.

### (d) Vitrified clay pipe (VCP)

VCP is manufactured from clays and shales and vitrified at high temperatures. VCP is available in several strength classifications, and is specified by nominal pipe diameter, strength and type of joint. The product should be manufactured in accordance with one or more of the following standard specifications:

**ASTM C4/AASHTO M179**—Clay Drain Tile. These specifications cover drain tile from 4- through 30-inch (100 through 750 mm) diameter in standard, extra quality, and heavy duty strengths.

**ASTM C498**—Clay Drain Tile, Perforated. This specification covers perforated drain tile from 4- through 18-inch (100 through 450 mm) diameters in standard, extra quality, heavy duty, and extra strength.

**ASTM C700/M65**—Vitrified Clay Pipe, Extra-Strength, Standard Strength, and Perforated. These specifications cover perforated and nonperforated pipe from 3- through 42-inch (75 through 1,050 mm) diameters in extra strength and standard strength.

### (e) Other materials and products

Geocomposites, geomembranes, geotextiles, aggregates, wick drains, and pump and lift stations may not be covered by conservation practice standards. The requirements for such materials and products must be specified in construction contract documents by an engineer. Contact individual manufacturers for more detail on specific products.

## 650.1426 Appurtenances

### (a) Surface inlets

Surface inlets should be used in low areas where surface drainage otherwise cannot be provided. They must be properly constructed to prevent washouts and silting of the line. Surface inlets should be avoided wherever possible. If silt is a hazard, place a silt trap (fig. 14-40) at a convenient location immediately downstream from the inlet or use a blind inlet (fig. 14-41). Blind inlets allow entry of surface water from small ponded areas into the drain without an open riser. The sand-gravel material for the porous medium must be appropriately designed to keep out sediment and prevent piping of base soil material, yet provide free water movement into the drain.

### (b) Junction boxes

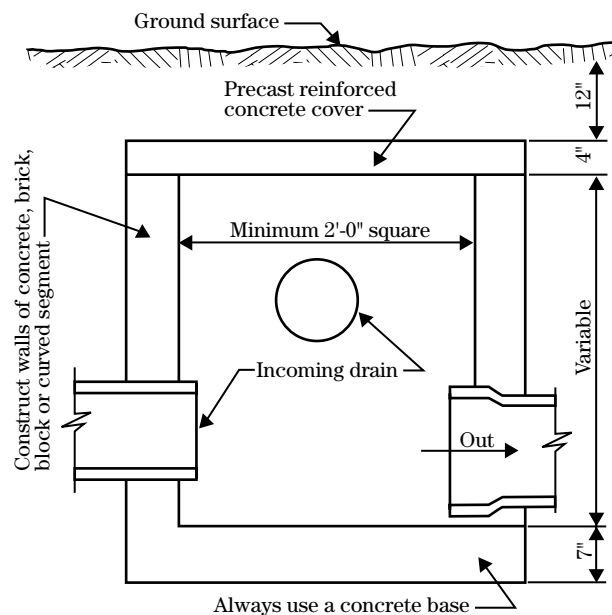
Junction boxes should be used where two or more main or submain drains join or where several laterals join at different elevations. If the junction is in a cultivated field, the box should be constructed so that the top is at least 18 inches below the surface of the ground. It can be capped and covered and its position referenced for future relocation (fig. 14-40).

### (c) Vents and relief wells

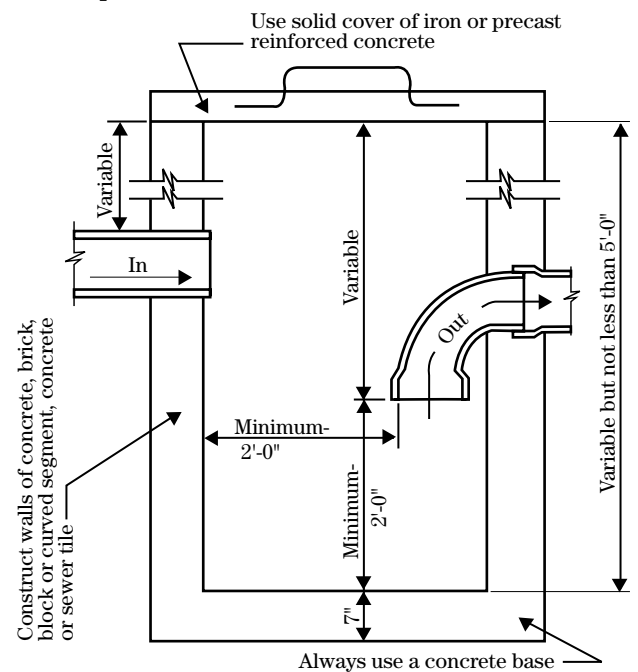
Vents, or breathers, are used to alleviate vacuum or negative pressure in the line. Breathers should be used where the line changes abruptly from a flat section to a steep section. Permanent fence crossings are good locations for installation. Relief wells relieve pressure in the line. They should be installed where steep sections change to flat sections unless the flatter section has about 25 percent greater capacity than the steeper section. They should be used on lines that have surface inlets, particularly when such inlets are large (fig. 14-42).

**Figure 14-40** Junction box and silt trap

#### Junction box

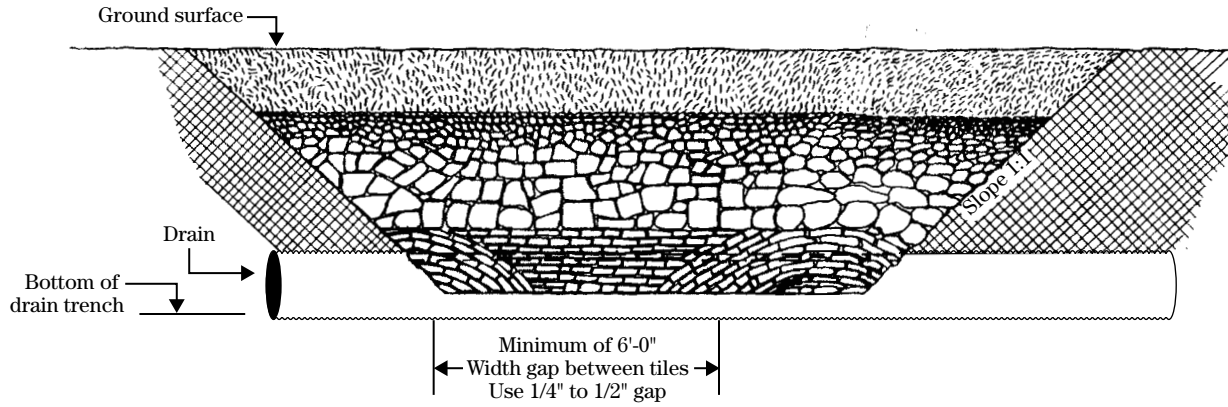


#### Silt trap

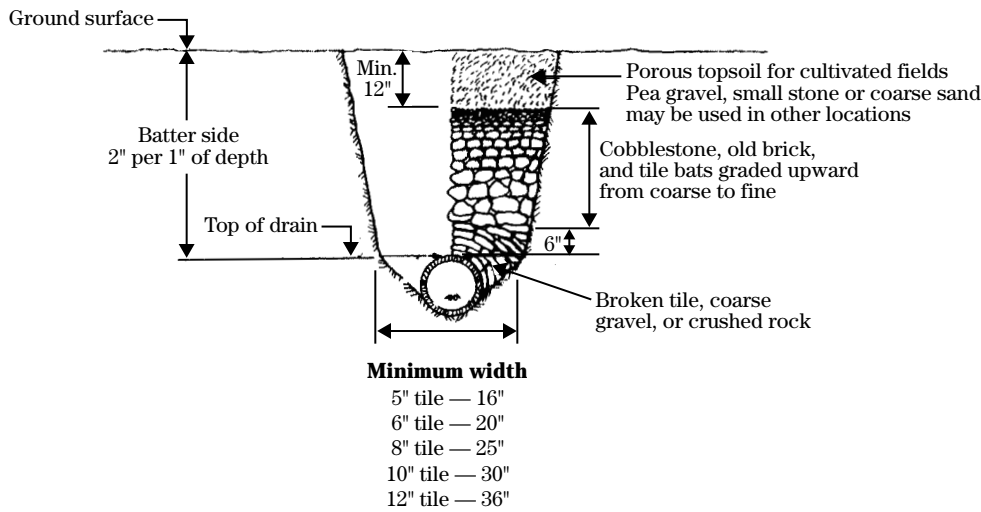


**Figure 14-41** Blind surface inlet

**Elevation**



**Cross-Section**

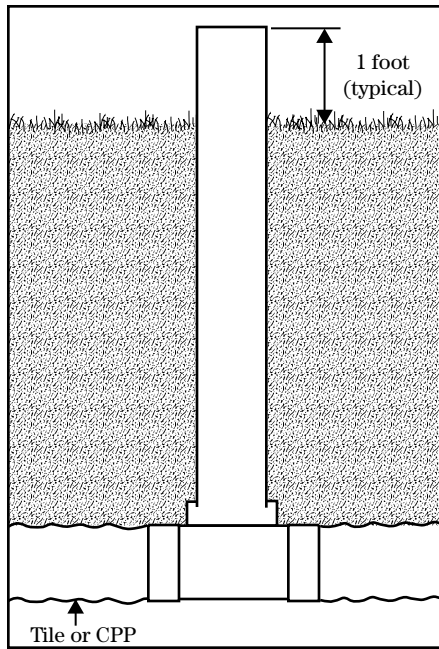


(d) Outlet protection

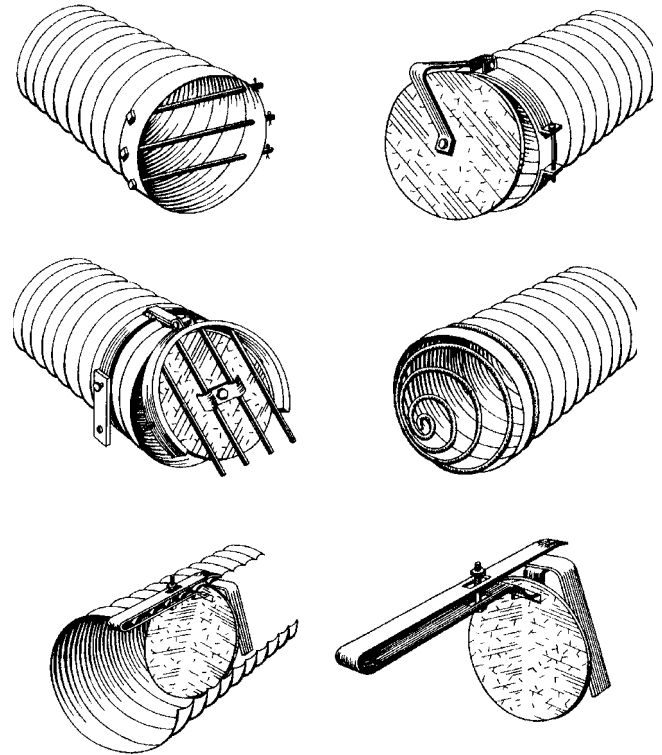
Where drains outlet into an open ditch, the end of the drainage line should be protected. If surface water enters the outlet at the same location as the drain, some type of structure, such as a headwall or earth berm, is needed over the outlet. Where there is no surface water, the most practical and economical outlet is a section of rigid pipe. The pipe should conform to the requirements shown in figure 14-43.

Where burning to control weeds may occur, the pipe should be fireproof. A swing gate or some type of grating or coarse screen should be used on all outlets to exclude rodents and other small animals (fig. 14-44). The screen mesh should not be less than 1 inch. Swing gates, rather than fixed screens or grates, should be used where surface water enters a system directly.

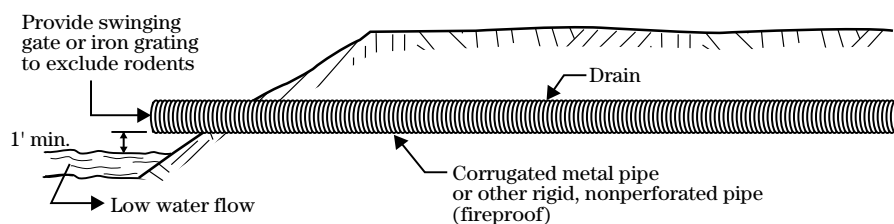
**Figure 14-42** Vents or relief wells



**Figure 14-44** Outlet pipe protection



**Figure 14-43** Pipe outlet



---

## 650.1427 Drain installation

### (a) Inspection of materials

All materials of a subsurface drainage system should be inspected before the system is installed. Materials should be satisfactory for the intended use and should meet standards and specifications. Any defective or damaged clay or concrete drain tile should be rejected, and defective or damaged sections of plastic tubing should be removed. The perforations in the plastic tubing must be the proper size. Check pipe for the specification to which it is manufactured (ASTM, AASHTO) as well as NRCS Practice Standard.

### (b) Storage of materials

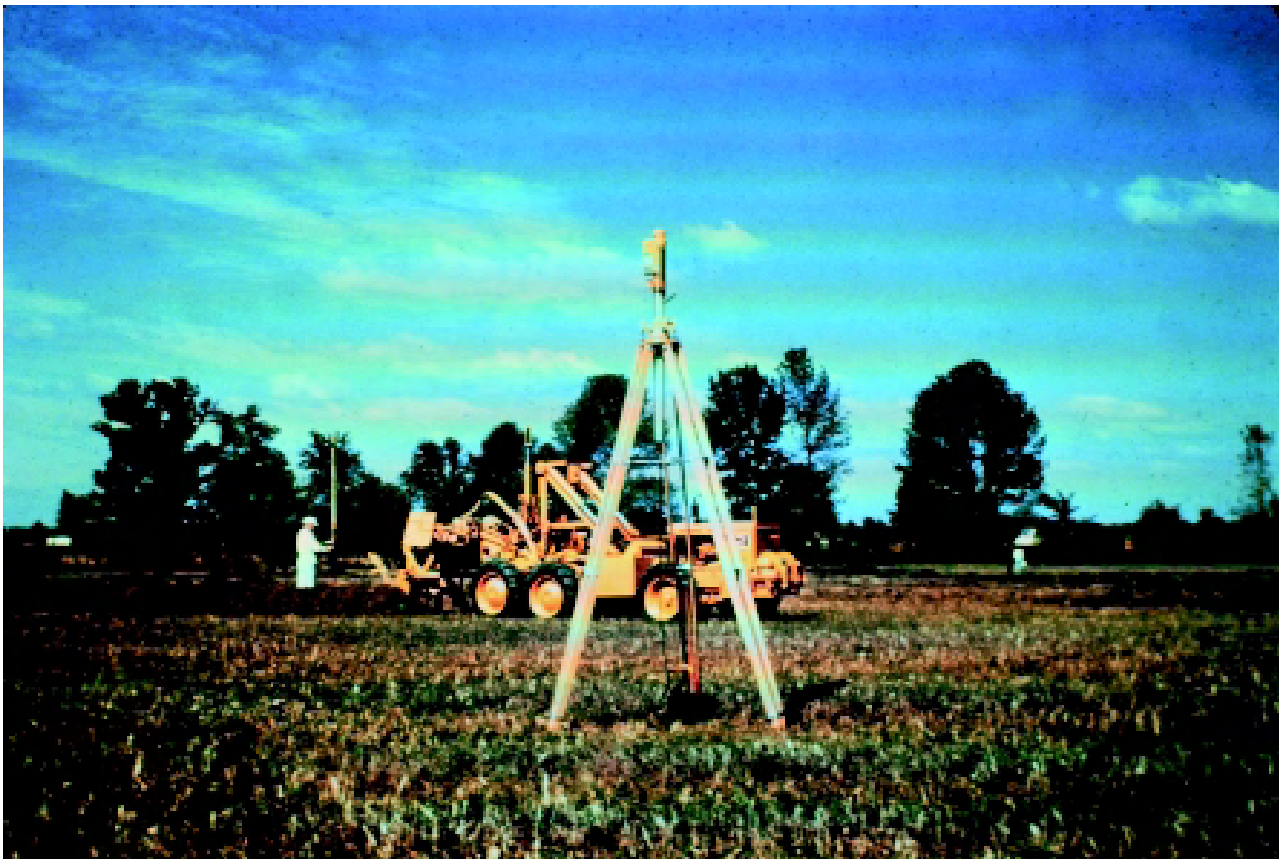
Drainage materials should be protected from damage during handling and storage. More precautions should be taken to protect plastic tubing. End caps can be used if rodents are a problem. Tubing that has filter wrap should be covered. Because tubing can be harmed by excessive exposure to ultraviolet rays, it must be protected from long exposures to sunlight. Coils of tubing should be stacked no more than four high, and reels should not be stacked.

### (c) Staking

Presently, field staking is at a minimum because most installations are done with laser controlled equipment (fig. 14-45).

---

**Figure 14-45** Laser grade control



### (d) Utilities

Special caution must be taken when trench or trenchless work is performed because of the danger if utilities are too near. Many jurisdictions have systems in place that require notification and location of utility lines before any excavations. Most require advance notification when excavation is to take place and have special telephone numbers for notification. Some states and metropolitan areas use a single telephone contact to alert local utility companies of pending construction activities (ASCE 1993).

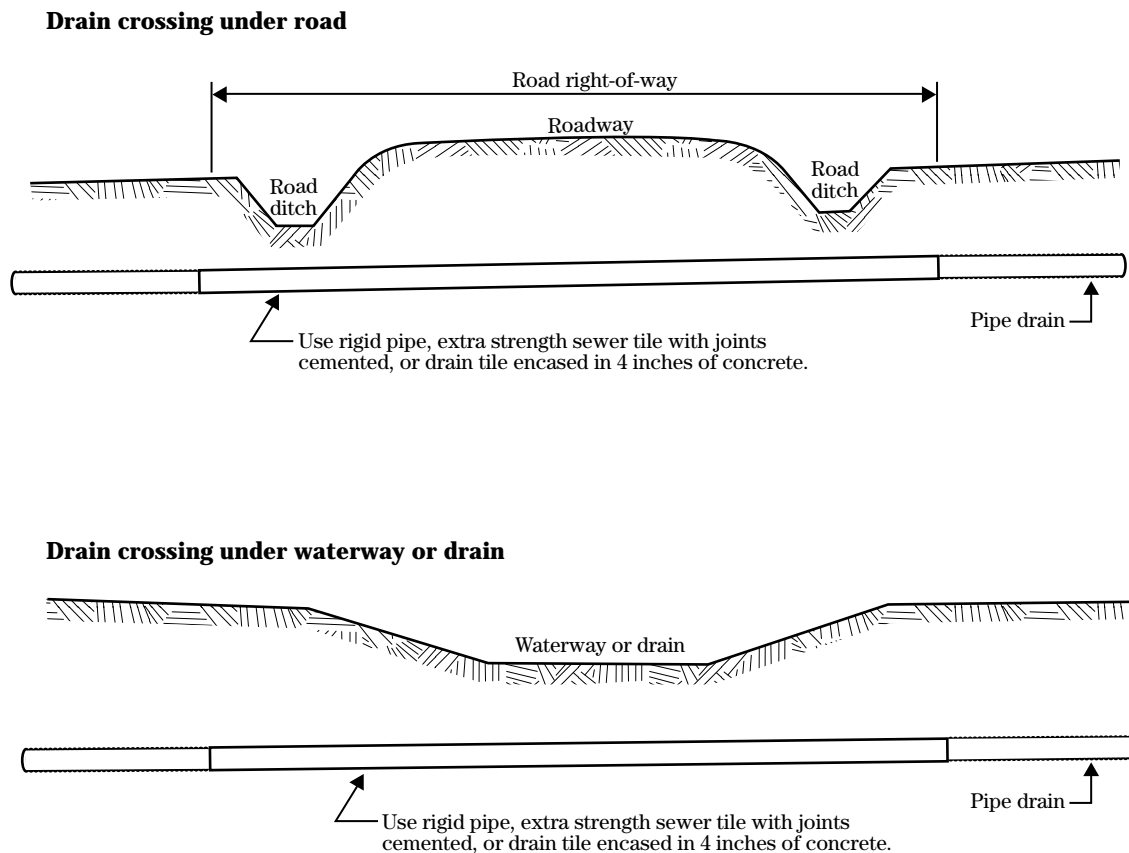
Utilities should be located when preparing plans, and procedures are needed to assure contractors have noted the utilities and have taken the necessary precautions. The location of all underground utilities and structures should be indicated on construction plans

or drawings. Safety is the primary concern, but interruption of services can create tremendous economic problems. Whether underground utilities are shown on the plans or not, the contractor is required by OSHA and possibly local or state law to contact local utility companies to ascertain if there is a potential for involvement.

### (e) Crossing waterways and roads

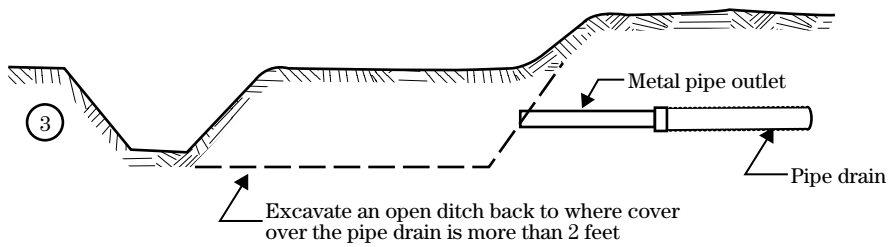
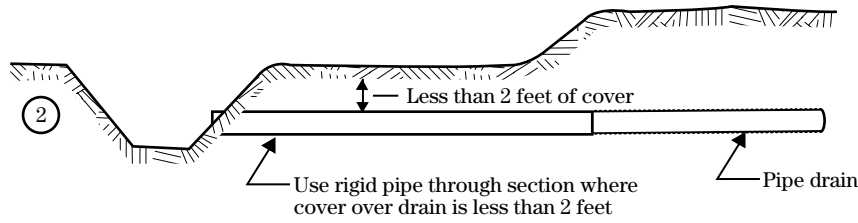
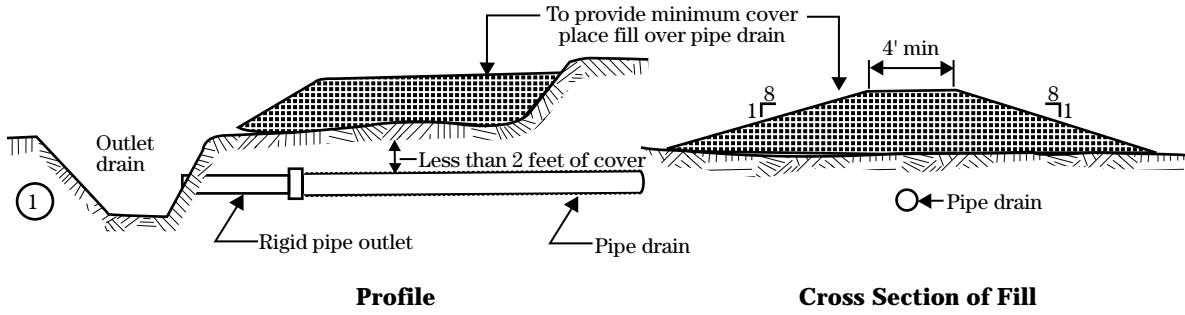
Special precautions should be taken where drains are placed under waterways or roads. Figure 14-46 provides some guidance for these crossings, but, if exceptionally heavy trucks and equipment are expected, an engineer should be consulted.

**Figure 14-46** Drain crossings and outlets



**Figure 14-46** Drain crossings and outlets (Continued)

**Methods for handling shallow depths at drain outlet**





## (f) Shaping the trench bottom

The bottom of the drain trench should be shaped so that a fourth or more of the drain's circumference is on solid ground. Trenching machines shape the trench properly as a part of the trenching operation. Backhoe buckets can also be modified to provide a proper shape. Where drains are laid through unstable pockets of soil, one of the following materials should be placed in the bottom of the trench to support the drain:

- stable soil
- crushed rock
- sand/gravel bedding

For corrugated plastic pipe, a specially-shaped groove must be made in the trench bottom if the design does not call for a gravel envelope. The groove shape can be a semicircle, trapezoid, or a 90-degree V. A 90-degree V-groove of sufficient depth is recommended for 3- to 6-inch pipe; however, if the pipe is installed on a steep grade, the bottom of the trench should be shaped to fit the pipe closely (fig. 14-47).

## (g) Laying corrugated plastic pipe (CPP)

Trenching machines or drainage plows are used to install most CPP. Any stretch that occurs during installation decreases the pipe strength somewhat and may pull perforations open wider than is desirable.

The amount of stretch that occurs during installation depends on the temperature of the CPP at the time it is installed, the amount and duration of drag that occurs when the CPP is fed through the installation equipment, and the stretch resistance of the pipe. The use of a power feeder is recommended for all sizes of CPP. Stretch, which is expressed as a percentage of length, should not exceed 5 percent.

## (h) Drain envelope installation

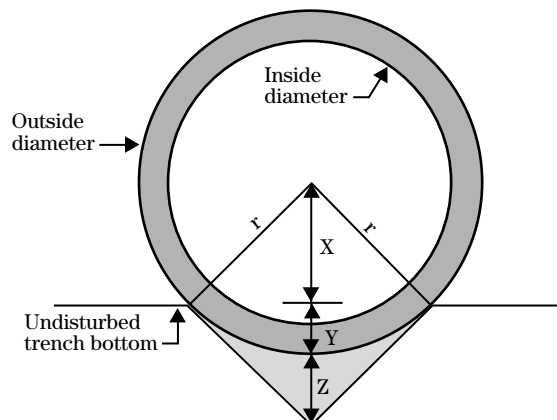
### (1) Drain filter envelopes

The best quality filter envelope material cannot compensate for improper installation, especially in fine, weakly structured soils that are saturated. Reliable drain envelope material will only be successful if installed under favorable physical soil conditions. General excess wetness of a soil may adversely affect structural stability, hence the soil manipulation caused by the trenching operation while installing drains may destroy the soil structure. This leads to soil slaking, enhanced risk of mineral clogging of filter envelopes and pipes, and a low hydraulic conductivity of the soil itself. Gravel filter envelopes tend to be less susceptible to poor installation conditions, but they can also fail because of adverse conditions at the time of installation. Geotextile filter envelopes are normally prewrapped and have sufficient mechanical strength to withstand the mechanical stresses of installation. Because of this, attention should be primarily on preserving the hydraulic function.

**Figure 14-47** Dimensions for a 90 degree V groove for corrugated plastic pipe

| Diameter (D) | r (D/2) | X (0.707r) | Y (0.293r) | Z (0.414r) |
|--------------|---------|------------|------------|------------|
| 3            | 1.5     | 1.060      | 0.439      | 0.621      |
| 4            | 2.0     | 1.414      | 0.586      | 0.828      |
| 5            | 2.5     | 1.768      | 0.732      | 1.036      |
| 6            | 3.0     | 2.121      | 0.879      | 1.242      |
| 8            | 4.0     | 2.828      | 1.171      | 1.657      |

<sup>a</sup>Values are based on typical outside diameter, which is assumed to be 20 percent greater than inside diameter.



The ideal condition for installation of subsurface drains is to place the drains in an unsaturated soil. If the soil has a high water table that cannot be lowered before installation, every effort should be made to preserve the existing soil structure and to protect the drain from trench wall failure. Adjusting the forward speed of the installation machine may help to limit the destruction of soil structure. If the condition of the excavated material is observed, it can be a guide to the proper machine speed. The machine should move fast enough to preserve the structure of the soil and not turn the excavated soil into a slurry. Simultaneous and instantaneous backfilling can prevent trench wall failure.

Drain plows have been developed that install drains with synthetic and gravel drain envelopes. Plowed in (trenchless) drains avoid many of the problems of trenched or backhoe excavated drain installation. Unfortunately, they present their own unique set of problems. They are limited to shallow depths and small pipe sizes, and may produce compaction around the drain under certain soil texture and moisture conditions. Moreover rocky soils can be a problem for this equipment.

## (2) Sand-gravel drain envelopes

Most of the water entering a subsurface drain moves through openings in the sides and bottom of the drain, below the hydraulic gradeline inside the drain. The hydraulic gradients that develop at the drain openings are often high enough to cause an unstable condition at the opening, and consequently piping of the soil material may occur. The noncohesiveness of many soils makes them particularly susceptible to movement when saturated. For these reasons, an adequate amount of filter envelope material is needed around the drain pipe.

Where drains are laid by hand, a layer of drain envelope material is placed in the bottom of the trench and is leveled to the design grade before the drain is laid. The drain pipe is then put into place and covered with envelope material to the required depth. The trench is then backfilled with soil. Some trenching machines are fitted with two hoppers for placing drain envelope material under and over a drain on a continuous basis. One hopper near the digging device covers the trench bottom with the required thickness of drain envelope material. The pipe is placed and the second hopper at

the rear of the trenching machine covers the pipe with drain envelope material.

In a common variation of the two hopper design, the pipe is guided through an enclosed single gravel hopper chute and emerges at the rear of the shield along with the gravel. In either case, the shield design is critical. If gravel segregation occurs within the shield, an improper gradation results and often leads to drain failure. Also, the design must be such that the pipe is not subject to tension caused by friction between the gravel and the shield walls. Such tension results in stretching the pipe beyond acceptable limits.

Drainage contractors have recently developed procedures for placing drain envelope material completely around a drain pipe in one operation using a single hopper. Single hopper placement is used for both rigid and flexible pipes. The pipe within the machine is suspended above the bottom of the trench so the granular envelope material can flow around the pipe. This single stage placement has resulted in material economies since it is possible to make an approximately concentric drain envelope by preshaping the trench bottom. Drain plows that install flexible corrugated plastic drain pipes with drain envelopes have uniformly concentric envelope placement.

In unstable soil the drain pipe and drain envelope are sometimes displaced by soil movement before and during backfilling. The sides of the open trench may fall or slough causing lateral misalignment of the pipes. If the soil around or in the bottom of the trench is saturated and unstable, it may move upward as a fluid displacing the envelope material and pushing the pipe out of line. Simultaneous backfilling is particularly desirable in unstable soil conditions. Movement of saturated unstable soil may also cause puddling of the backfill material and plugging of the filter envelope, or any drain envelope material, during construction. A slurry in the bottom of a trench generally causes immediate and complete failure of synthetic drain envelope material.

Protection of the drain envelope and drain system immediately following installation is important. No heavy loads, mechanical or hydraulic, should be imposed until the soil in the trench is consolidated. The loose backfill material will settle naturally with time. Passage of a light weight vehicle wheel in the trench

speeds up the process, but care must be taken to avoid crushing the drain pipe.

Application of irrigation water to unconsolidated material in the trenches to settle the backfill is a practice that should be done carefully. Muddy water moving through the porous backfill material directly into the filter envelope under high hydraulic heads can cause plugging of the filter envelope material at the drain openings. Such plugging reduces the effectiveness of the drain envelope. It may also result in sedimentation in the drain or even complete plugging of the filter envelope.

### (3) Envelope thickness

One of the benefits of drain envelope placement is the increase in permeability along the pipe that enables water to flow more freely to the open joints or perforations. The effect is similar to converting the pipe from one with limited openings to one that is completely permeable. This increased permeability can probably be obtained with an envelope 0.5 inches thick. Theoretically, corrugated pipes should be perforated in every corrugation to reduce secondary convergence at the openings.

Increasing the diameter of the drain envelope effectively reduces the waterflow velocity and exit gradient at the soil and envelope interface (Willardson and Walker 1979), thereby decreasing the probability of soil particle movement. If the permeable hydraulic envelope material is considered to be an extension of the pipe diameter, then the thicker the envelope the better. Some practical limitations to increasing drain envelope thickness include:

- The perimeter of the envelope through which flow occurs increases as the first power of the diameter of the envelope, while the amount of envelope material required increases as the square of the diameter.
- Doubling the diameter of the envelope and consequently decreasing the inflow velocity at the soil and envelope interface by half would require four times the volume of envelope material.

Corrugated plastic drain pipes with close perforation spacing reduce the requirement for a hydraulic envelope material to transport water to widely spaced openings that were common where 1- to 3-foot lengths

of rigid pipe were used for drainage. The practical problems of placement probably dictates a design minimum sand-gravel drain envelope thickness of approximately 3 inches. The principal reason for a thicker envelope in a problem soil would be to reduce the exit gradient to a value below the hydraulic failure gradient of the soil and to nullify the effects of construction inconsistencies. Figure 14-39 illustrates sand-gravel envelope placement recommendations.

## (i) Alignment and joints

### (1) Plastic pipe

Manufactured couplers should be used at all joints and fittings of corrugated plastic pipe, at all changes in direction where the centerline radius is less than three times the pipe diameter, at changes in diameter, and at the end of the line. All connections must be compatible with the pipe. Where certain fittings are not available, hand-cut connections are acceptable if they are reinforced with a cement mortar or other material that makes a strong, tight joint. The connection should not create a means of obstructing flow, catching debris inside the conduit, or allowing soil to enter the line.

### (2) Tile

Alignment in main and lateral drains should generally be straight, and junction boxes should be used to affect changes in direction. **Y** and **T** joints can be used. Manufactured connections are preferred, but chipped or fitted connections that are sealed may be installed if manufactured connections are not available.

Laterals should be connected to mains so that their centerlines meet. Any curves in mains and laterals should have a radius of more than 50 feet. If gaps in excess of 1/4 inch in clay soils or 1/8 inch in sandy soils occur in the outer side of a curved line, they should be covered with an impermeable material.

Joints between tile laid in straight or nearly straight lines should be about 1/8 inch wide unless the soil is sandy. Tile laid in sandy soil should be butted together. If gaps exceed 1/4 inch in clay soils or 1/8 inch in sand, they should be covered with broken tile batts or wrapped with impermeable material. In certain soils where experience shows that tile lines fill with sediment within a few years, joints should be protected by wrapping or covering.

## (j) Safety and protection during construction

At the end of each day's work, the end of the drain being placed should be completely closed to prevent small animals or, in the event of rain, silt and debris from entering the line. A wooden or metal plate or some other device can be used. Upon completion of the line, the upper end of the drain should be closed tightly using a plate, end cap, or some other permanent material.

Contractors are responsible for construction site safety. Federal regulations covering safety for all types of construction are published in the Safety and Health Regulations for Construction under the Department of Labor, Occupational Safety and Health Administration (OSHA). Many states, municipalities, and other local agencies have established codes and safety practices regarding construction. These regulations apply to subsurface drainage installation as well as all types of construction, including alteration and repair work. Personnel and contractors associated with drainage installation should be thoroughly familiar with the safety requirements and follow the required practices, procedures, and standards.

## (k) Blinding and backfill

As soon as the drains are placed, they should be blinded by covering them with soil to a depth of 6 to 12 inches. They should not be left exposed overnight because damage can occur from rain and trench caving. Loose topsoil, either taken from the sides of the trench or excavated during trenching operations, provides good blinding material.

Backfilling of the trench should be done as soon after blinding as possible to prevent damage from surface water. This generally is done by mechanical means. Some trenchers have backfilling attachments that place the excavated material in the trench as the drain is laid.

## (l) Protection for biological and mineral clogging

The following installation procedures may minimize ochre problems for shallow drains in humid areas.

**In ochreous areas, drains should not be installed below the water table.** If possible, drains should be installed during the dry season when the water table is low because the iron in the soil will be in the insoluble form and stabilization of the drain and surrounding soil will help to minimize the possibility of ochre becoming a serious problem.

**Drains should open into ditches, rather than through collector systems.** If a small area in a field is ochreous, the trouble could be confined to a single drain. Cleaning is also easier for single drains.

**Clogging is more severe shortly after drain installation.** The best cleaning method is to jet the drains during the first year after installation rather than wait until the drains are clogged. One method of cleaning has vents at the upper end of the lines that are used as ports to pour large quantities of water into the drains for flushing action. This method will not clean the valleys of the corrugations.

**Shallow drains and closely spaced drains that flow infrequently are not as troublesome, even though the site may be rated serious for ochre potential.**

**Drains in marl soils generally have fewer problems, unless the drains are installed deep in the soil profile.**

**Avoid blinding the drain with topsoil or organic materials.**

## (m) Checking

The most practical way to check the drain installation is after the drain has been laid and before the trench is backfilled; however, checking can be done using a probe after backfilling.

## (n) As-built plans

As-built or record drawings are recommended for future reference. They can be done by GPS mapping process, aerial photography, or traditional survey methods.

## 650.1428 Maintenance

Maintenance of subsurface drains is needed throughout the drain's expected useful life. Outlets should be inspected regularly. If they are not fire-resistant or fire-proof, they need to be protected from weed burning operations. Corrugated plastic tubing is not suitable for the outlet section. Maintenance problems are reduced if the outlet is a short section of solid pipe. The gates or screens of outlets must be checked to assure that entry of rodents and other small animals is restricted and that they are free of sediment build-up, weeds, debris, and seasonal ice blockage.

General observation of the entire subsurface drainage system will reveal areas of possible failure. Sinkholes or cave-ins over the drains indicate that soil piping problems have occurred. The problem may be a broken or collapsed drainage conduit or an opening in the filter or envelope material that allows soil material to enter the drain. Following the spring drying period, puddles or wet areas can indicate a plugged line or filter fabric or areas where additional drains are needed.

### (a) Jet cleaning

High pressure jet cleaning has been successfully used for removal of ochre, silt, and roots from subsurface drains (fig. 14-48). This practice has been used extensively in Northern Europe and in the U.S.

Timely maintenance of subsurface drainage systems in areas of ochre development is critical. Subsurface drains should not be installed in sites having permanent ochre potential unless some provision is made for frequent jet cleaning.

Temporary ochre as a clogging factor may diminish or disappear over a period of 3 to 8 years if drains are maintained in a free-flowing condition. It generally occurs rapidly and often can be detected at drain outlets within the first few months after drain installation. If drains can be maintained in working order, ferrous iron reaching them may diminish over a period of time.

Permanent ochre is the most serious problem because it continues to be a clogging agent for the life of the drainage system, regardless of treatment. The use of high and low pressure water jetting has been successful in cleaning many drains clogged with ochre. Nozzle

**Figure 14-48** High pressure jet cleaning



pressure should not exceed 400 psi in sandy soils; otherwise sand around the drains may become unstable and flow into the drain. Jetting nozzles designed for agricultural drains should be used rather than those designed for cleaning municipal sewer lines. Jet cleaning should not be delayed until the ochre has aged and become crystalline.

### (b) Acid solutions

A second method for cleaning drains involves an acid solution to dissolve the iron. This method cannot be used with synthetic envelopes, and the outflow after treatment may need to be neutralized to prevent pollution downstream. Some acids, especially sulfuric, may damage concrete lines.

**650.1430 Interception drainage design**

Interception drainage is used to intercept surface and subsurface water. The investigation, planning, and construction of surface interception drains follow the requirements and procedures given for surface drainage. Interception of subsurface water is discussed in part 624 (section 16) of the National Engineering Handbook.

**(a) Ground water movement**

Ground water elevation and movement are needed for proper establishment of interceptor drains. Some of the more common conditions indicating the need for interception drainage are illustrated in figure 14-49, which is a sketch of a valley cross section extending beyond the ridge into the adjoining valley.

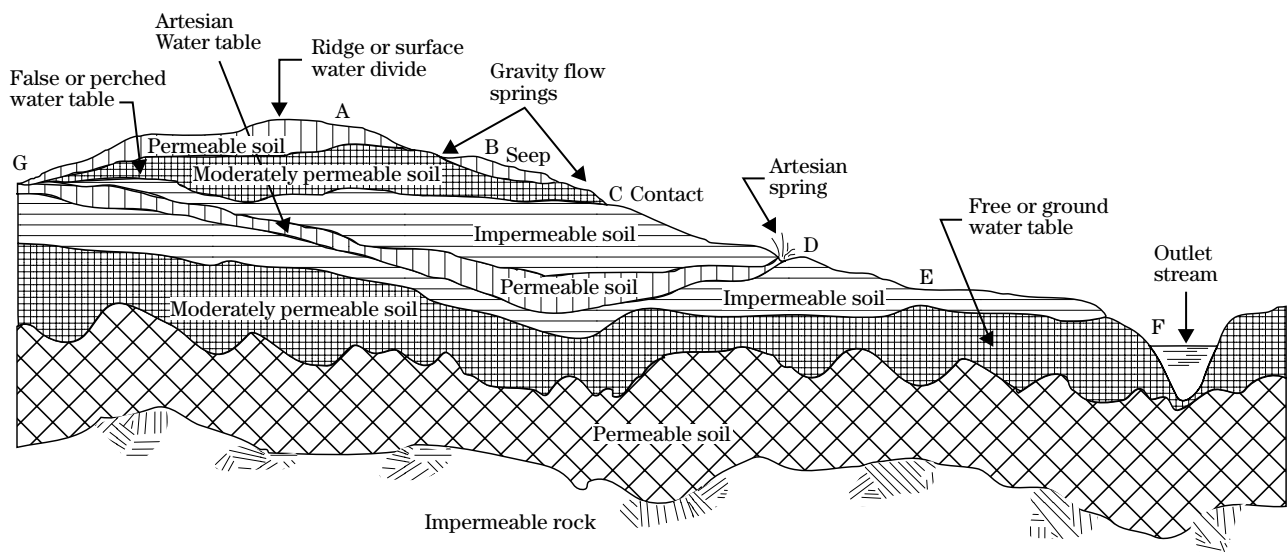
Most ground water for which drainage is required comes from recent rainfall that accumulates on the soil or within the upper part of the soil profile. After replenishing the soil to water-holding capacity, the excess water moves downward through the soil to the

water table or builds up above restricting layers. Here it accumulates and moves laterally, often parallel with the land slope, toward an outlet. Its movement may reach the surface and return to the subsurface a number of times in its course to an outlet.

In a valley, barriers within 8 to 20 inches of the soil surface often cause a perched water table above the true water table. A true water table seldom is encountered until well down the valley side slopes or on the valley floor. For example, in figure 14-49, rainfall penetrating a permeable surface soil below the ridge at **A** may accumulate water over a less permeable subsoil during wet periods. Resistance to movement into the subsoil diverts most of the water over the less permeable layer to appear at the surface at location **B** as a wet weather seep. During the summer, such seep spots may completely dry out. Also, where soil is shallow over less permeable layers, a false water table close to the surface may accumulate sufficient water to pond at the surface in wet seasons and later completely disappear.

The same water movement also can develop seeps at point **C**. However, a larger collecting area and more complete interception by the impervious layer may accumulate sufficient water to produce a flowing spring, particularly if it is in a depression where the water converges and is confined in a small area. On

**Figure 14-49** Ground water movement



the other hand, a rock ledge or compact layer may lie as a shelf with visible flow only at the depressions, even though this may be a small part of the total water coming to the surface along the same approximate contour.

Proceeding down into the valley trough, flow from adjoining watersheds can complicate the problem. Springs developed from these sources frequently have year-round discharge. When the flow is confined between impermeable layers, such as at **D**, it may build up a head of water a considerable distance above the point of issue. This can create an artesian supply that can discharge under pressure over an extended area. If the flow is not free but is covered by a mantle of moderately permeable to fine textured soil, artesian springs may saturate an extensive area at great depths by pressure and capillary action. Because of this, the location and treatment of these springs are difficult. Abrupt changes in grade of fine textured soils, shown in **E**, may slow water movement on the flatter slope enough to cause water accumulation and wetness at the surface.

On some sites, open observation wells or piezometers are necessary to locate the source and direction in which subsurface flow takes place.

### (b) Location of interceptor

In the planning and establishment of interceptor drains for both surface and subsurface water, the location of the outlet is of utmost importance. Insofar as possible, cross drains should be laid out to use the best natural outlet available. Because the interceptor may intercept other drainageways and add their discharge to the selected outlet, it is necessary to check the adequacy of the outlet to be used. Often, discharge can be spread over a well sodded pasture, stony field, or into gently sloping woods.

If a satisfactory natural outlet is unavailable, special channels can be constructed. Vegetative outlets on slopes are preferred over masonry or similar channels because of their economy. They should be established well ahead of the interceptors so that the turf can safely handle the concentrated flow. If vegetative outlets must handle continuous flow, as supplied by springs, the center of the channel should be troughed to confine low flows.

If surface wetness is undesirable, subsurface drainage can be provided by a conduit placed along one side of the channel, well into the bank and away from possible surface wash. Subsurface drains should be vented at breaks in grade to reduce suction at the head of the slope and pressure at the base. In flats at the base of slopes, main or lateral ditches of trapezoidal or parabolic section can be used.

In planning and establishing an interceptor diversion, a few well placed lines at obvious seep planes and distinct changes in slope may be sufficient. In such cases, a detailed map may not be needed, and the line can be staked directly on the site. If subsurface interception must also be considered, the approximate location should be determined first from observations of surface conditions and preliminary borings.

After the line is staked, additional borings should be taken along and across the staked line and the alignment shifted until good interception is obtained. In irregular bowl-shaped areas, some changes in grade or shifting of the diversion lines upslope or downslope may be needed to obtain reasonably uniform farming strips, headlands, and access points for farming equipment.

If a uniform grade from one side to the other causes considerable divergence or location of the drain away from the approximate line of seepage and desirable pattern of farming strips, several parallel drains may be needed. If this is done, the least needed length of drain generally results from placing the shorter line at the higher elevation near the outlet. As an alternate, if an outlet is also available on the opposite side of the seep area, an alternate method is to break the grade along a single line so that the fall is in both directions. The most advantageous point of breaking grade may require several trials until grade and alignment provide the desired location, interception, and outlet points. Such sites often have so many irregularities and outlet location problems that a complete contour map may be needed as an aid to planning.

Interception drainage may be accomplished by open drains or subsurface pipe drains (fig. 14-50). A channel used for controlling surface water (fig. 14-51), commonly called a diversion, may be shallower than one required to intercept subsurface water movement. The open drain must have sufficient depth to intercept subsurface water movement. The drains are frequently



V-shaped, with the bottom and top rounded by construction and cultivation so they nearly conform to parabolic sections.

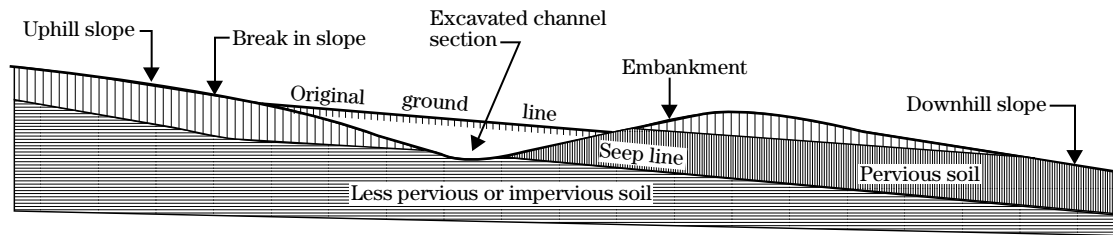
Side slopes preferably should be 6:1 or flatter for ease of construction and farming. However, 4:1 or steeper side slopes may be necessary on land that has slopes of more than 12 percent.

Where a series of interceptor ditches is necessary to reduce the length of slope and contributing drainage area, spacing ordinarily should not exceed 200 feet for slowly permeable soils. More often, break in slope,

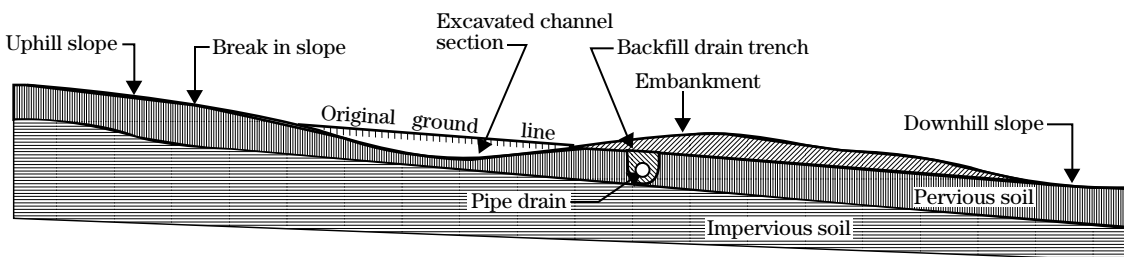
location of spring or seep lines, and the necessary location of the top interceptor result in spacing of less than 200 feet. In more permeable soils, erosion control requirements may govern spacing.

If an interceptor open drain carries spring flow and elimination of continuous wetness in the open drain is desirable, a shallow diversion that has an auxiliary subsurface pipe drain can be used. The subsurface drain can be placed on either side of the surface drain; however, in most shallow soils, a location slightly downhill from the drain provides deeper interception and added cover from the embankment (fig. 14-51).

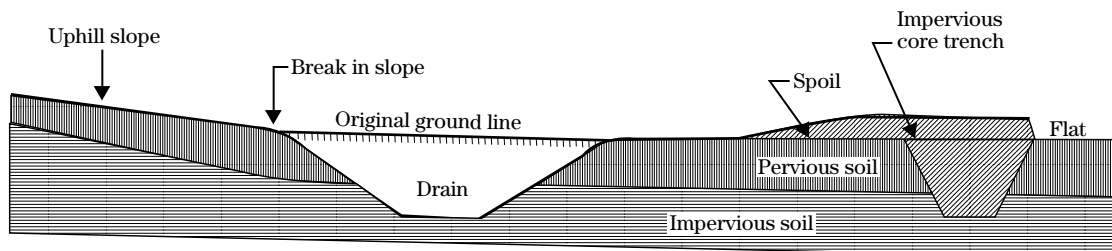
**Figure 14-50** Typical interceptor installations



**A. - Cross section showing open drain as surface water diversion and interceptor of surface and subsurface water from sloping lands.**

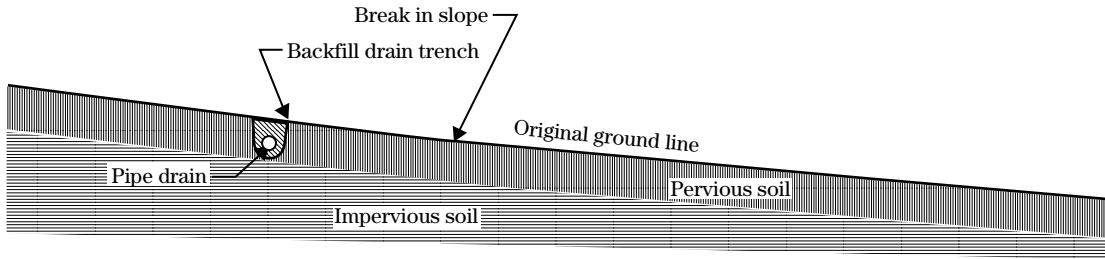


**B. - Cross section showing open drain as surface water diversion with pipe drain as subsurface interceptor.**

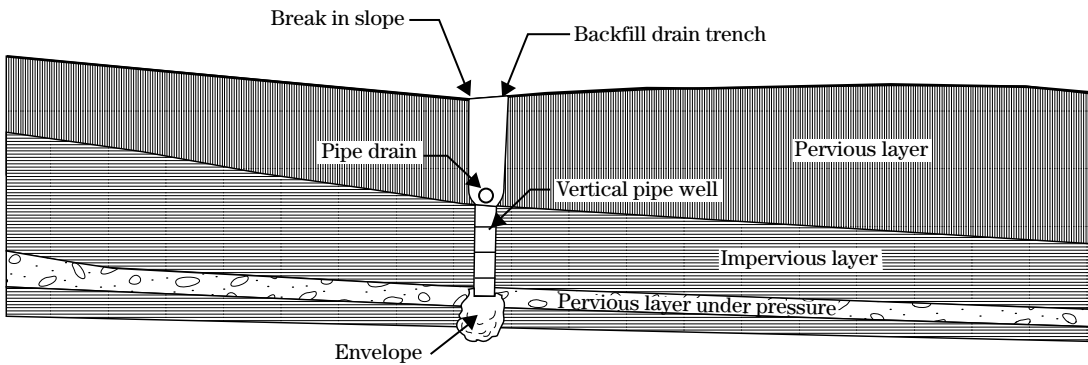


**C. - Cross section showing open drain as surface water diversion and subsurface water interceptor located at interface of sloping and flat lands.**

**Figure 14-50** Typical interceptor installations (Continued)

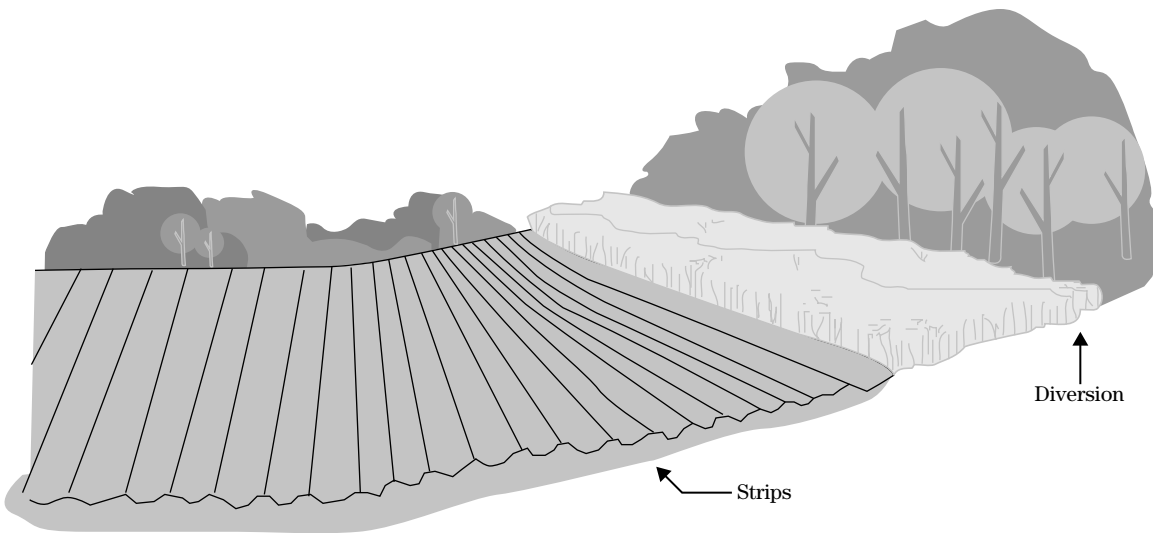


**D. - Cross section showing drain as subsurface interceptor.**



**E. - Cross section showing relief well and interceptor drain.**

**Figure 14-51** Diversion system on moderate to steep slopes



The subsurface drain need not follow the course of the surface open drain throughout its length if topography warrants deviation.

An open drain that has a standard trapezoidal or parabolic cross section (fig. 14-50C) can be used to intercept surface water at the base of a slope surrounding a depression or at the outer edge of a flood plain (fig. 14-52). The depth of the open drain must be ample to provide:

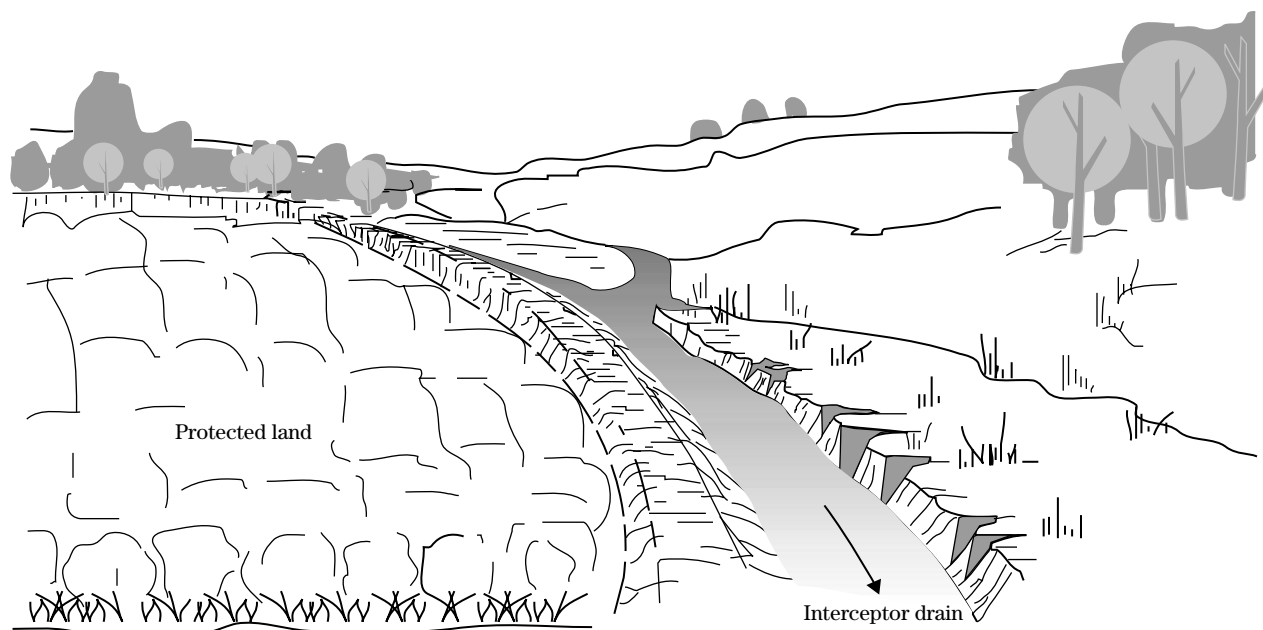
- necessary subsurface interception,
- allowance for shrinkage where peat and muck are involved, and
- lateral movement of water if the drain is also used as an outlet for internal drainage of the protected area.

Spoil always should be placed on the downslope bank to permit free movement of upland water into the drain. It can also be used in diking to gain added channel capacity for overflow protection. If diking is not needed, spoil should be spread to blend into the surrounding landscape and to facilitate maintenance.

If drainage areas are small, subsurface drainage often can be used alone for interception of seeps and springs (fig. 14-50D). The drainage lines are generally close to breaks in grades so that the drain has adequate cover and proper depth for intercepting the seepage. Added cover can be obtained on many sites by moving the lines slightly uphill above the break in slope where the impervious layer generally is at a greater depth. The bottom of the drain should be just within the impervious layer. If minimum cover is not available at this depth, the drain should be placed as far into the impervious layer as necessary to attain the needed cover. This may reduce the amount of flow into the pipe and its potential capacity, but deepening and widening the trench and installing 4 to 6 inches of envelope material around the pipe improve flow into the drain. In fine textured soils, permeable material should be used as backfill over the line to within plowed depth.

Isolated seeps at elevations above the drain can be tapped with stub relief drains to avoid additional long lines across the slope.

**Figure 14-52** Interceptor drain on bottom land



If pervious layers are considerably below normal drain depth or deep artesian flow is present, water under pressure may saturate an area well downslope. Vertical relief wells or pits can be installed at intervals along the cross drain down to an impervious layer or springhead, and the excess flow can rise through these vertical pipes and discharge into the cross drain (fig. 14–50E). Open pits can be filled with bank run gravel or coarse sand, serving much as a French drain to permit water from deep-seated springs to rise into the cross drain. Construct by installing pipe and filling it with filter material; after which the pipe is withdrawn, leaving a vertical or chimney drain.

### (c) Use of surface or subsurface drains

Open drains can be used to lower or control the water table where subsurface drains are not feasible. They are used in shallow, hardpan soils where the depth of the soil does not permit satisfactory installation of subsurface drains. They are also used in deep soils in cultivated fields, either as temporary measures or permanent installations. Where the entrance of surface water can cause bank erosion, adequate devices, such as pipe inlets, should be considered.

Open drains may be used as temporary installations to intercept and monitor subsurface flow. Often an open drain is retained as a permanent installation if the flow is so great that a pipe drain installation would be too costly.

Drains must be deep enough to tap and provide an outlet for ground water that is in shallow, permeable strata or in waterbearing sand. The spacing of drains varies with soil permeability and drainage requirements. The capacity of the open drains generally is greater than required because of the required depth and the construction equipment used. Refer to National Engineering Handbook, part 624 (section 16) for additional information and to State technical guides for recommendations.

The spacing between field ditches can be calculated by the same drainage formulas used for subsurface drains after converting the wetted perimeter  $u$  to the radius of drain pipe  $r$ , thus:

$$u = 3.14r$$

Advantages of using open drains:

- Nearly always have a smaller initial cost than subsurface drains.
- Are more easily inspected.
- Are applicable in many soils where subsurface drains are not recommended.
- Can be used on a very flat gradient where the permissible depth of the outlet is not adequate to permit the installation of subsurface drains at the minimum required grade.
- Can be used in lieu of subsurface drains to avoid problems with iron ochre.
- Are generally more accessible by equipment for cleaning and maintenance purposes.

The disadvantages:

- Reduce the area of land available for farming, especially to unstable soils that require flat side slopes.
- Are more difficult and costly to maintain than subsurface drains.
- Limit access and interrupt farming patterns.
- Pose both social and environmental impacts.

### (d) Size of drains

#### (1) Humid areas

Table 14–9 can be used to determine the required capacity of single random interception drains in some humid areas. If one line is insufficient, additional lines may be used.

**Table 14–9** Interception drain inflow rates

| Soil texture           | Inflow rate per 1,000 feet of line (ft <sup>3</sup> /s)* |
|------------------------|--|
| Coarse sand and gravel | 0.15 to 1.00   |
| Sand loam              | 0.07 to 0.25   |
| Silt loam              | 0.04 to 0.10   |
| Clay and clay loam     | 0.02 to 0.20   |

\* Discharge of flowing springs or direct entry of surface flow through a surface inlet must be added. Such flow should be measured or estimated. Required inflow rates for interceptor drains on sloping land should be increased by 10 percent for 2 to 5 percent slopes, by 20 percent for 5 to 12 percent slopes, and by 30 percent for slopes over 12 percent.

**(2) Irrigated areas in the West**

Darcy's Law, which relates to the flow of water in saturated soils, has been used to approximate the discharge of irrigation water. Measuring discharge of an open pilot interceptor has been employed. Local experience with interception drainage is generally relied upon. Additional information is in the National Engineering Handbook, part 624 (section 16) and in State drainage guides. The procedure for obtaining the drain size after the discharge has been determined is described in section 650.1423(h).

**(e) Grades and velocities**

Both minimum and maximum grades should be considered in design and installation of subsurface drains.

**(1) Minimum grades**

If silt or fine sand is a problem, minimum grades should produce a velocity of at least 1.4 feet per second, if possible, to keep the material suspended in the effluent. Grades as low as 0.1 foot per 100 feet are permissible where silt is not a problem or where a filter is used.

**(2) Maximum grades**

Because grades frequently must vary with topographic conditions, it is not always possible to hold to specific maximums. Where practical, main drains should not be placed on grades of more than 2 percent. Special precautions must be taken where locations and conditions require the use of steep grades. Some added precautions that should be considered include:

- Use nonperforated pipe for steep sections.
- If perforated drainage pipe is used, a filter fabric or sand-gravel envelope should be used to prevent soil from entering the drain.
- Use bell-and-spigot or tongue-and-groove concrete pipe with sealed joints and sand-gravel envelope material for unsealed joints.
- Use tile that is uniform in size and shape and has smooth ends or joints.
- Lay the tile in a firm foundation with tight-fitting joints bound with the best material available.

A breather pipe near the beginning of a steep section and a relief well at the point where a steep section changes to a flat section should be considered. This will be determined by the velocities in the drain, the soil in which the drain is laid, and the capacity of the drain below the steep section with respect to that in the steep section.



**650.1440 Introduction**

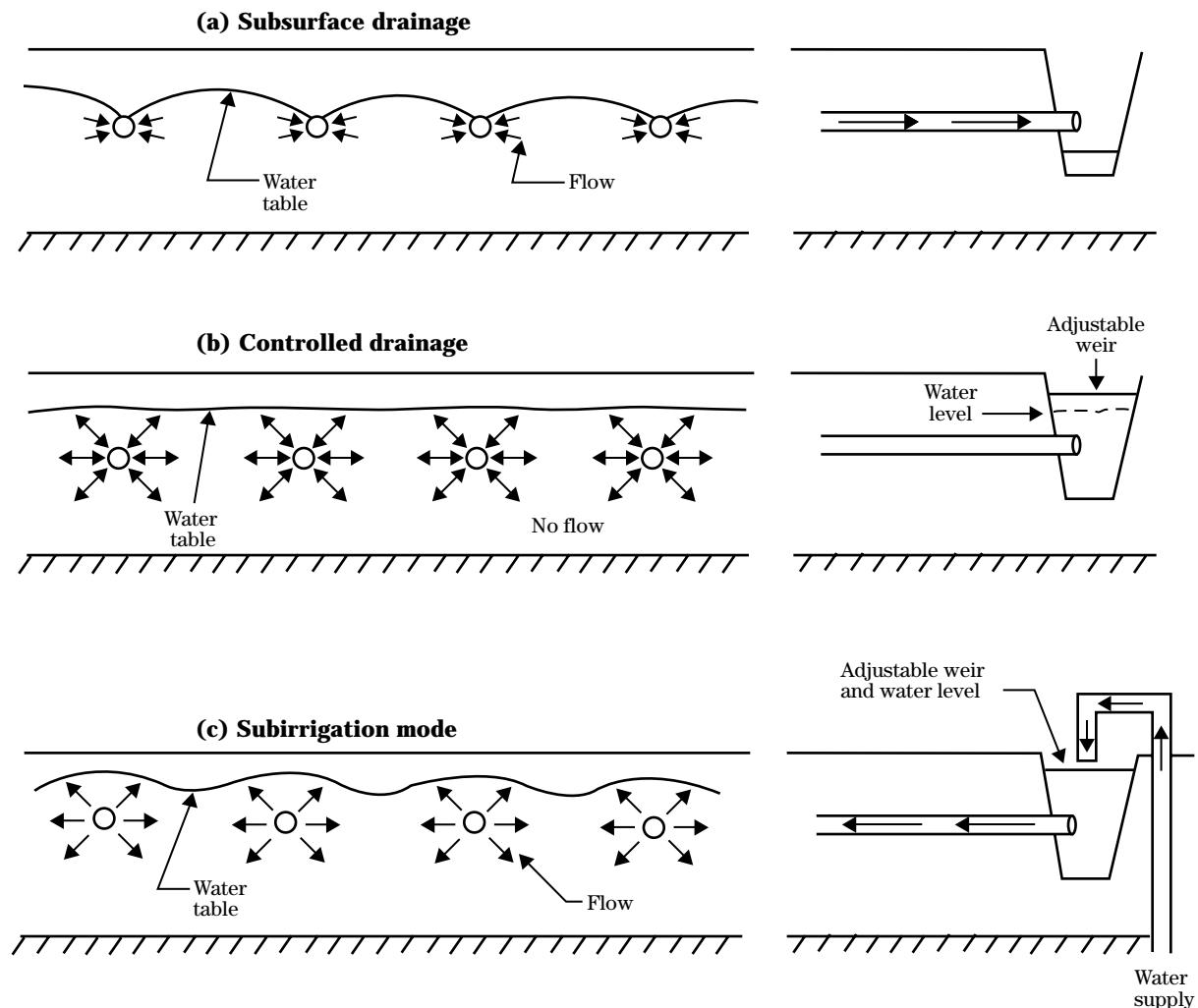
This subchapter describes water table management, which includes controlled drainage and subirrigation. See chapter 10, NEH part 624 for additional details. Controlled drainage and subirrigation have many benefits. Controlled drainage, as the name implies, is a modification of a drainage system that restricts or allows for management of outflow. Subirrigation is typically an additional refinement of controlled drainage in which a water source is added to maintain a water table at the desired stage to provide capillary water for plant use. Refer to figure 14-53.

Water table management systems not only improve crop production and reduce erosion, but also protect water quality.

Most water table management systems include water-control structures that raise or lower the water table, as needed. Lowering the water table in a soil increases the infiltration of water by providing more room in the soil profile for water storage. The result is less surface runoff, less erosion, and less sedimentation of surface water.

Nitrates (mostly from nitrogen fertilizer) commonly move in solution with water and have been measured in subsurface drain flows. Some studies suggest that

**Figure 14-53** Water table management alternatives



ground water can be denitrified and the nitrogen returned to the atmosphere as a gas if the water table is maintained close to the soil surface. This is especially true during the nongrowing, dormant periods. The use of water table management practices to reduce the loss of nitrates to public water is being studied for various soil, cropping, and climatic conditions. Management of the systems to accomplish denitrification is critical.

Interest in water table management systems has increased in the Atlantic Coastal Plain and other humid areas. The NRCS has helped landowners install water-control structures in open drains in for water quality protection and water conservation. The drainage water management facilities are closely monitored to avoid conflict with the objectives of protection and enhancement of wetlands and to guide management of the systems to achieve the intended purpose.

## 650.1441 Controlled drainage

Controlled drainage is beneficial for water quality protection and water conservation. This form of water table management does not include adding an outside water source. Controlled drainage has been used historically in organic and muck soils, but is also applicable in mineral soils. Some drainage systems may remove water needed for crop production later in the season. Structures that retard drainage water losses can partly overcome this problem. The conserved water is used as needed during the growing season.

Growing rice in flooded basins requires water levels above ground surface to be kept within certain limits in accordance with the water requirements of the different growth stages. If rice is rotated with other crops in an area that has a subsurface drainage system, the drain outlets should have a water level control structure that can prevent or allow the outflow of drainage water as needed.

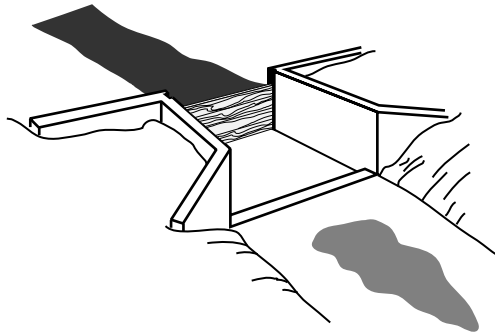
Structures for water control normally use spillways fitted with stoplogs or gates to control the water level. Control structures in conjunction with wells may be placed in the subsurface drain system. They generally are a type of manhole fitted with stoplogs or adjustable metal slides that control the flow of water in the subsurface drain system (fig. 14-54). Chapter 6 of the Engineering Field Handbook gives more information on using structures for water control.

Management of controlled drainage systems is beneficial in protection of surface and ground water quality. Local technical guides give detailed information on retention of nutrients and agricultural chemicals.

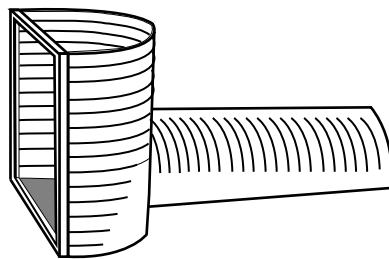


**Figure 14-54** Water control structures

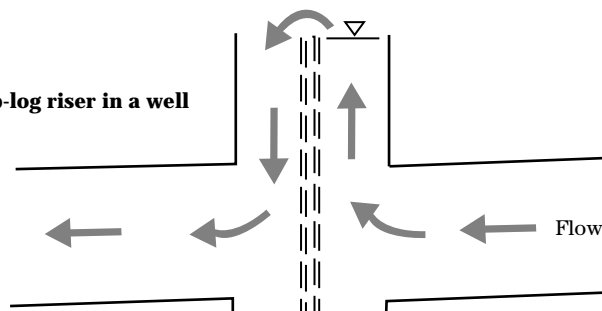
**Typical stop-log structure**



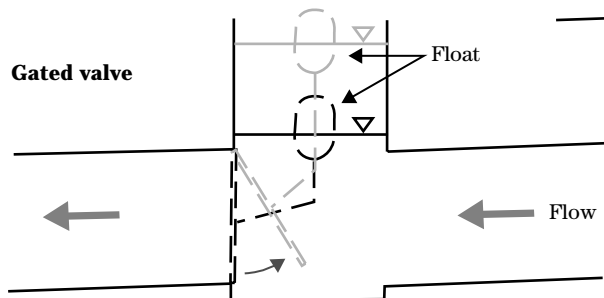
**Stop-log pipe riser**



**Stop-log riser in a well**



**Gated valve**



## 650.1442 Subirrigation

Water table management (WTM) is the control of ground water level by regulating the flow of water in the drainage and subirrigation modes. It is accomplished by the use of structures that control the rate of flow or maintain a desired water surface elevation in natural or artificial channels. A source of water along with a pumping plant may be needed to satisfy the subirrigation objective. Figure 14-53 shows the effect of using these water management alternatives with a subsurface drainage system.

### (a) General requirements

For water table management to be successful, the following conditions generally must be met.

- The site has a relatively flat surface and the slope is no greater than 1 percent.
- The soils at the site have a moderate-to-high hydraulic conductivity.
- The soil has a natural high water table or a shallow, impermeable layer. Deep seepage losses should not be a problem where these conditions exist.
- The site has a satisfactory drainage outlet. This can be a pumped or natural gravity outlet.
- An adequate water supply is available.
- Saline or sodic soil conditions can be maintained at an acceptable level for efficient production of crops.
- Unacceptable degradation of offsite water will not result from operation of the system.
- Benefits of the proposed water table control will justify installation of the system.

### (b) Planning a water table management system

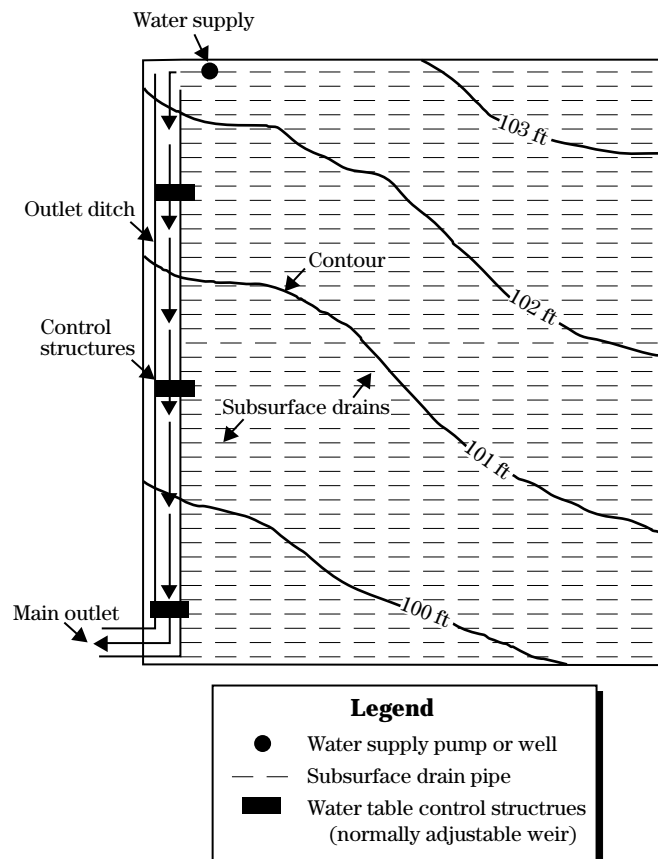
The entire area impacted by the management of the WTM system must be evaluated. The control of the water table by an adjustable weir or gates may impact adjoining fields. Figure 14-54 shows typical water table management structures. A topographic survey of the field or fields is needed to plan the system, including avoiding an adverse impact on adjacent fields and

drainage systems. Figure 14-55 depicts basic layout features of a WTM system.

The type of system that can be used must be determined. It should be consistent with the landowner's needs and management requirements. Planning considerations include:

- Type and layout of the surface and subsurface drainage system.
- Need for land smoothing or precision leveling.
- Alignment of system to best fit topography, spacing, and location of structures. Structures should be located to maintain the water table within an acceptable level below the root zone so that good drainage is provided when needed and water is furnished by capillary movement from the water table throughout the growing season.

**Figure 14-55** Field layout of WTM system



The most critical factor is the feasibility of maintaining a water table, which is often dependent on the presence of a barrier. This is discussed later as well as hydraulic conductivity and determining spacing of subsurface drain laterals to provide for both drainage and subirrigation.

### (1) Water table location

The location of the natural seasonal high water table in the soil profile is critical. A seasonal high water table indicates that the soil can maintain the water table required for subirrigation during dry periods. If the seasonal high water table is more than 30 inches below the surface (with natural drainage), the soil is considered to be well drained, and a water table may be difficult to develop and maintain close enough to the root zone to supply the plant's water needs because of excessive seepage.

In most areas where water table control systems will be used, the natural seasonal water table has been altered by artificial drainage, and the depth of the drainage channels control the depth to the modified seasonal water table. Excessive lateral seepage can be a problem if the proposed system is surrounded by drainage channels that cannot be controlled or by fields that have excessively deep seasonal water tables. The depth to the seasonal water table during periods of a crop's peak demand for water must be evaluated and potential seepage losses estimated.

### (2) Barrier

If water table management is successful, a barrier on which to build the artificial high water table during the

growing season must occur at a reasonable depth. An impermeable layer or a permanent water table must be reasonably assured.

### (3) Hydraulic conductivity

Hydraulic conductivity is the most important soil property affecting the design of a water table management system. The final design must be based on actual field measured conductivity. A soil hydraulic conductivity of 0.75 inches per hour should be used as a benchmark for planning. If the flow rate is less than 0.75 inches per hour, the cost of installing the system may be the limiting factor. However, all costs should be evaluated before rejecting the site. If other system costs, especially that of water supply, are low, soils that have a hydraulic conductivity of less than 0.75 inches per hour may still be economical.

Appendix 14-C provides detailed information on the auger-hole method of determining hydraulic conductivity. A single value will be determined to use in all calculations, and this value must be representative of the entire field. At least one hydraulic conductivity test per 10 acres is recommended. As the complexity of the soil increases, more tests are needed to assure that a representative value is obtained. Figure 14-56 shows an example field that requires only one test per 10 acres. The site characteristics are:

- One soil with uniform horizons over entire field. Loam is 26 inches thick. Fine sand continuous to 10 feet.
- Conductivity values vary slightly between test hole, but are uniform enough that only 1 per 10 acres is needed.

**Figure 14-56** Field layout of hydraulic conductivity tests (1 per 10 acres)

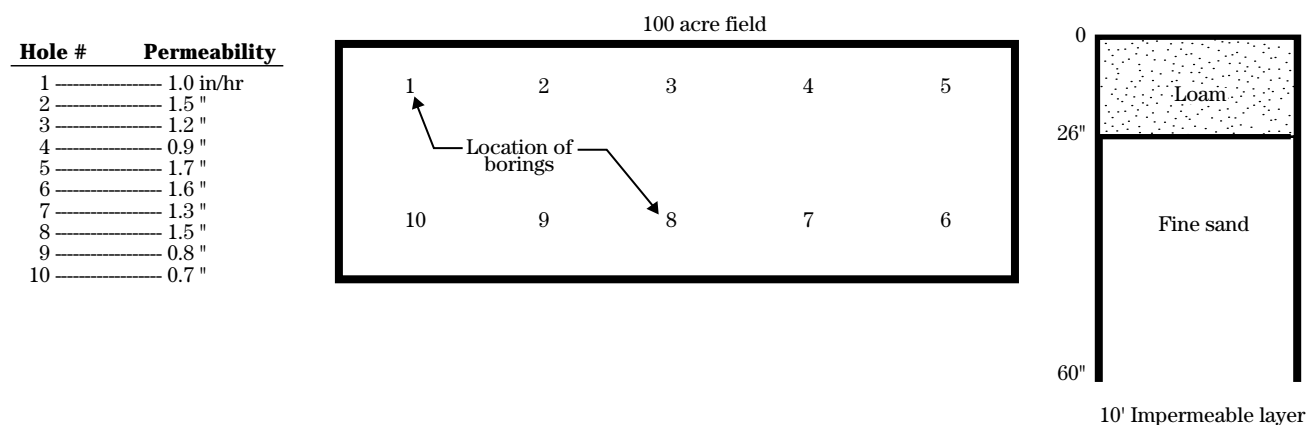


Figure 14–57 shows an example of a more complex field that requires many tests. Site characteristics are:

- Three soil types.
- Considerable variations in soil characteristics. Many variations in texture and thickness of horizons within each soil type.
- Readings vary considerably over a wide range in soil C and are uniform in soils A and B.

Determining the amount of variability that can be tolerated before additional readings are needed can be left to the discretion of the designer or determined by a statistical analysis. Regardless of the method used, the designer must obtain a representative value of the hydraulic conductivity of the field. If initial tests are performed and readings are uniform, no further tests are necessary.

**(i) Determining which hydraulic conductivity rate to use for design**—Only one rate can be chosen to represent each area that is to be designed as a single unit. This is often difficult because of variations in measurements. Computing the arithmetic average will not be adequate for design purposes because the

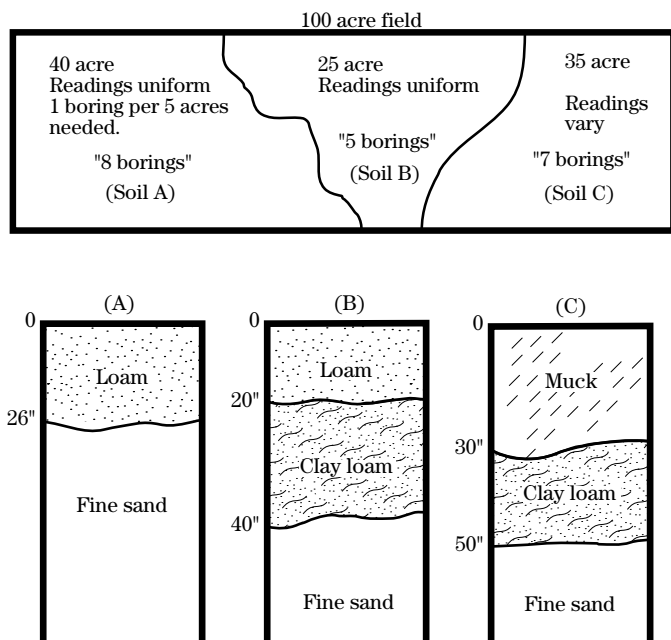
resultant tubing or ditch spacing will be too close if actual hydraulic conductivity is greater than average and too far apart when actual conductivity is less than the average. To keep things simple, the following method is recommended.

- Group all of the conductivity values according to the rate of flow using the following example. The range of these groupings can be varied based on the magnitude, variability, and arrangement of the conductivity values.

| Group     | Range of conductivity    |
|-----------|--------------------------|
| Very slow | Less than 0.05 inch/hour |
| Slow      | 0.05 - 0.5 inch/hour     |
| Moderate  | 0.5 - 2.0 inch/hour      |
| Rapid     | 2.0 inch/hour or more    |

- Subdivide the field according to the group of conductivity values. Each area can then be designed as a separate unit based on the selected hydraulic conductivity rate for that unit.
- If the field has several hydraulic conductivity group values so intertwined that they cannot be subdivided into separate areas and designed as individual units, the lowest conductivity that represents a majority of the area should be used to determine the design value.

**Figure 14–57** Field layout of hydraulic conductivity test (variable concentration based on complexity)



The simplest and most reliable method of determining the hydraulic conductivity of a soil is the "auger hole method" (see appendix 14D). The disadvantage of this method is that the tests must be made when a high water table is available.

The hydraulic conductivity of the soil profile should be measured from the surface of the soil to the impermeable layer (if less than 6 feet from the surface of the soil). The 6 foot limitation is based on field experience using normal equipment. Beyond this depth it becomes difficult, if not impossible, to determine the hydraulic conductivity of the soil using field techniques. If the impermeable layer is at a depth of more than 6 feet, the designer can extend the auger in the same hole or perform the auger hole tests in the bottom of an existing ditch. A procedure for estimating hydraulic conductivity and using Soil Interpretation Form 5, is presented in Section 650.1422(b), Soils.

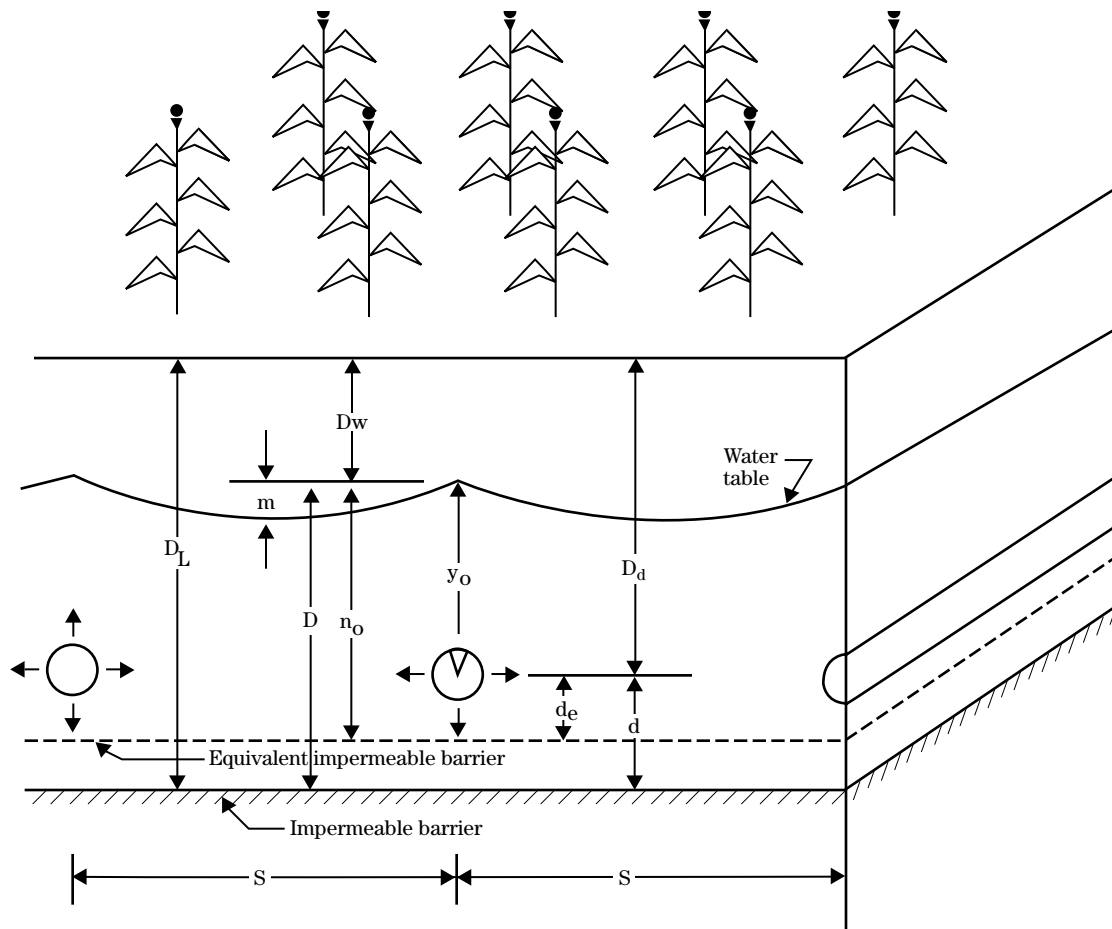
**(4) Lateral spacing**

If water is being added to the system, the water level over the drains must be maintained higher to create sufficient head to cause water to flow laterally outward from the drain. Figure 14-58 depicts the water table in the soil during subirrigation while water is being supplied to the laterals and at the same time is being withdrawn from the soil by evapotranspiration. It also details the notation to use in the design process and the terminology used to relate the position of the water table in relation to the ground surface, the laterals, and the barrier.

because the restricted drainage effect of holding the water table above the drains causes the drains to be less efficient. Further the subirrigation mode of moving water horizontally to the midpoint between laterals requires less space than for drainage alone. For the numerous systems designed and installed, the average lateral spacing is about 70 percent of the recommended drainage spacing from local drainage guides. Because of the many variables, it is recommended that the DRAINMOD computer program be used for the spacing of laterals. For additional details refer to NEH Part 624, Chapter 10, Water Table Control.

The spacing of subsurface drain laterals is less (placed closer together) for either controlled drainage or subirrigation than for drainage alone. This is basically

**Figure 14-58** Subirrigation lateral spacing and water table position



### (c) Operation of water table management system

Operation of a water table management system can be automated. However, until experience has proven the timing and selected stages for the structure settings that give the desired results, frequent observations, manual structure setting, and pump operation should be used. To conserve water and minimize the amount of pumping necessary, the controlled drainage mode should be used to the greatest extent feasible.

Monitoring wells in the field can provide for direct reading of water table levels that are correlated to stage settings of the control structures. As experience is gained, fewer well readings are needed to provide the information to operate the system. The water table should be maintained close enough to the root zone so that capillary upward flux as demonstrated on the ditch side slope in figure 14-59 provides all the water needed for evapotranspiration. If the water table is too far below the root zone, sufficient water may need to be provided at the source or moved through the soil profile rapidly enough to reestablish the desired water table level. Adequate drainage is needed at all crop stages.

**Figure 14-59** Monitoring water table depth



---

**650.1450 Drainage pumping**

Drainage pumping plants remove excess surface or ground water where it is impossible or economically infeasible to obtain gravity outlets for drainage. They are also used on sites that have adequate outlets except during periods of prolonged high water (fig. 14–60). A much more detailed description of drainage pumping is in NEH, Section 16, Drainage of Agricultural Lands.

**(a) Surface drainage pumping conditions**

Pumping for surface drainage may be feasible on the following landforms:

**Bottom lands or flatlands protected from flooding by dikes**, where gravity drainage is restricted because of periodic high stages in the outlet, or where the outlet has inadequate capacity. Floodgates are installed to permit the maximum gravity drainage possible while preventing the inflow of floodwater. The amount of pumping required can vary from a small percentage of the drainage flow to practically all of it.

**Coastal plains that do not afford enough slope to the water surface for gravity drainage.** Here, the land to be drained is diked, and pumping is done from a sump. The amount of the drainage water that must be pumped depends on the elevation of the land above tidewater. In some situations, the entire runoff must be pumped.

**Areas in which the runoff water is to be used for irrigation.** The area may or may not be diked, depending on the outlet situation for gravity drainage. Water control structures are necessary.

**Areas in which the soil requires a high degree of water table control**, such as in areas of organic soils. Pumping is sometimes required to lower water levels during wet periods and raise water levels during dry periods.

**(b) Subsurface drainage pumping conditions**

Conditions under which pumping for subsurface drainage may be feasible:

- Where it is desired to add the drainage water to the irrigation water.
- Where the outlet is at an elevation that does not permit gravity flow from drains located at depths required for adequate drainage.
- Where the indicated method of drainage is to pump the water from an underlying aquifer, which may or may not be under artesian pressure.

**(c) Relation of pumping plant to drainage system**

The pumping plant should be planned and designed as an integral part of the drainage system. The reconnaissance or preliminary survey determines the condition of the drainage outlet and whether pumping is required. A drainage system in which the pumping plant is designed into the system generally functions much more efficiently than one in which the pumping facilities are added after the system is installed because the outlet is inadequate.

**(1) Features that require coordination**

The pumping plant must be designed to pump the amount of water necessary to give adequate drainage against the total head expected. In determining this, disposing of all the runoff possible by diversion around the area and providing for all possible gravity flow through floodgates should be considered.

The plant should be located where it best serves the intended purposes. Condition of the foundation, access for servicing, proximity to sources of power, and locations that might be susceptible to vandalism should be considered. Where significant sump storage is available, the pumping plant should be located to take maximum advantage of the storage provided. The location should permit safe discharge into the outlet with a minimum of construction outside the diked area.

If possible, the plant should be easily accessible. Ordinarily, the dike can be widened to accommodate vehicular traffic. An all-weather access road is desirable.

The requirements for a stable foundation often conflict with the other requirements of location. Borings should be made and the location selected that has the best foundation conditions consistent with other site requirements. An unstable foundation material can considerably increase the cost of a pumping plant. A more intensive investigation before selecting the plant location often yields big dividends in reduced costs.

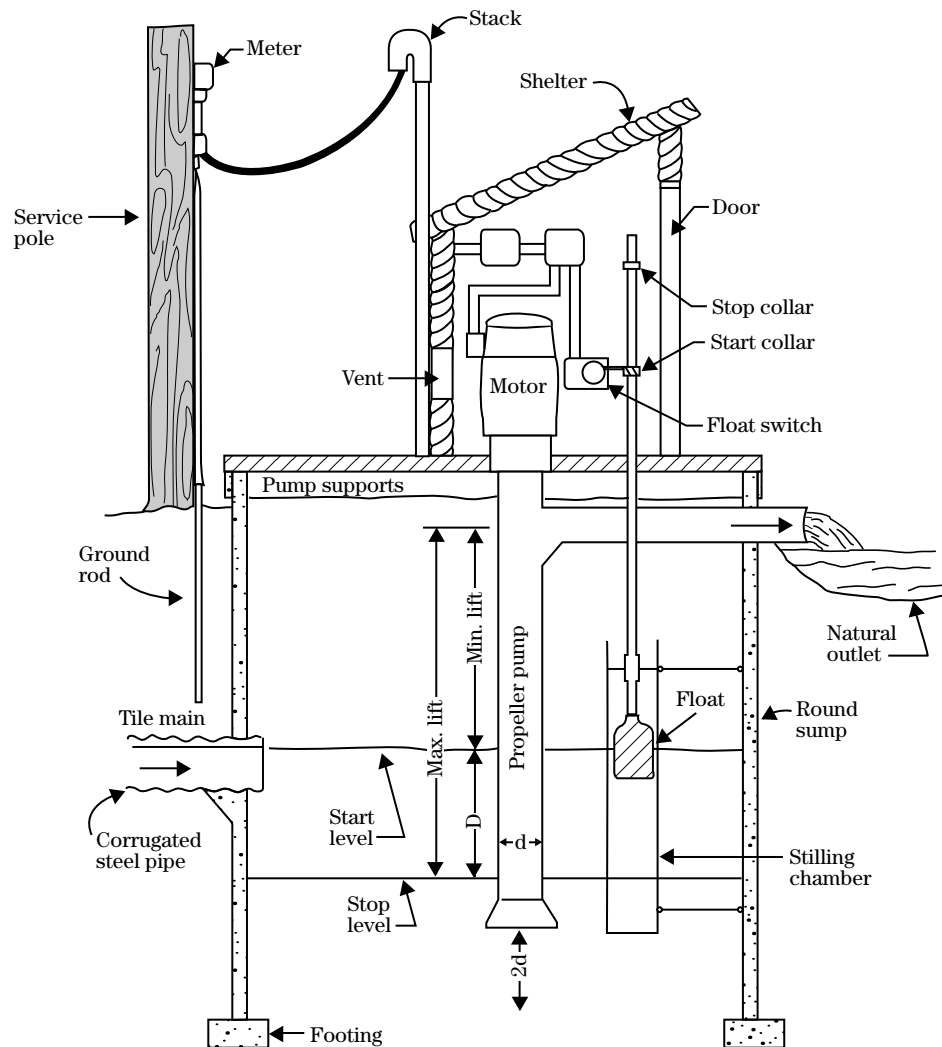
**(2) Sump storage**

Careful consideration should be given to providing storage for runoff within the diked area. The effective storage is that capacity in sump areas and ditches

between the lowest elevation at which drainage is by gravity, or the cutoff elevation for the pumps, and the elevation at which flooding of the land to be protected begins. This is determined largely by the topography of the project area and the type of drainage system. A sump for a subsurface drainage system may be only a circular well 8 feet or less in diameter that has 2 feet of effective storage.

A sizeable area near the surface drainage system outlet that is lower than the area to be drained can be used for storage without crop loss. Borrow pits of appreciable size for dike construction and drainage ditches that have sufficient storage capacity can also be used.

**Figure 14-60** Pump installation





All of the storage capacity available should be used to reduce the required pumping capacity, considering the economics of the project. For high-value, highly developed cultivated land, the only storage capacity that may be available is that in open ditches. For watersheds used for low-value crops and that may contain appreciable areas of undeveloped land, a rather large area of low-lying land may be devoted to sump storage. This will result in a less expensive pumping plant. Where the area needs to be developed to more intensive use, the pumping capacity can be increased and some of the area otherwise devoted to sump storage can be developed.

The ditches supplying runoff to the pumps must be capable of delivering water at the maximum pumping rate. The highest roughness factor considered likely to occur should be used to determine the ditch size for this requirement.

Sumps designed to collect and store large volumes of water generally collect runoff as well as subsurface drainage discharge. These sumps can be used where a uniform rate of discharge is desirable in the drainage outlet or where the discharge is desirable only during specified times.

The following formula helps determine sump storage requirements for continuous pumping operations over a specified time period:

$$S = V \left( 1 - \frac{I}{P} \right)$$

where:

$V$  = Total volume of drain water to be stored over a specified time period

$S$  = Sump storage (gallons)

$I$  = Inflow rate (gallons per minute)

$P$  = Pumping rate (gallons per minute)

The total time during which the pump will operate continuously is defined by:

$$T = \frac{V}{60P}$$

where:

$T$  = Pumping time (hr)

### Example:

If a continuous flow of 600 gpm is desired and an inflow of 250 gpm occurs for 12 hours, then the storage volume needed in the sump will be:

$$\begin{aligned} S &= 250 \times 12 \times 60 \times \left( 1 - \frac{250}{600} \right) \\ &= 104,994 \text{ gal} \end{aligned}$$

To convert this to cubic feet, divide the 104,994 gallons by 7.48.  $S = 14,037$  cubic feet.

The continuous flow of 600 gpm would occur for a time of:

$$\begin{aligned} t &= \frac{250 \times 12 \times 60}{60 \times 600} \\ &= 5 \text{ hrs} \end{aligned}$$

Thus sump and pumps can be selected for individual farm needs or desires.

Concrete sumps are most commonly used for subsurface drainage systems because they are easily equipped with automatic controls and require little space and minimum maintenance.

The sump capacity is based upon the inflow and pumping rate so that the pump cycle is sufficient to allow the pump to operate with an acceptable overall efficiency. A sump should be designed to allow about 10 cycles per hour in the pump system. If it exceeds 15 cycles per hour, pump efficiency and power costs may be undesirable.

The inflow rate, pumping rate, storage capacity, and cycle time for drainage outlets can be determined using the following formula.

$$\frac{60}{N} = \frac{S}{I} + \frac{S}{P - I}$$

where:

$P$  = Pumping rate (gpm)

$I$  = Inflow rate (gpm)

$S$  = Storage volume (gal) between the on and off stage of the sump

$N$  = Number of complete cycles per hour where the length of the complete cycle equals the standing time plus the running time

The following formula can be used to rearrange and change the storage from  $S$  in gallons to  $S$  in cubic feet:

$$N = \frac{7.48 \times I \times (P - I)}{P} \times S$$

This formula can also be used to compute the frequency of cycling for given values of  $S$  and  $P$  and for various rates of inflow.

The maximum  $S$  occurs when  $I = (1/2)P$ . For design purposes the amount of storage required in cubic feet is determined by the following equation:

$$S = \frac{2P}{N}$$

where:

$N$  = the maximum or permissible number of cycles per hour

$S$  = the storage in cubic feet

The sump depth between the on and off positions of the pump control and the cross-sectional area of the sump are chosen so that their product is equal to or greater than  $S$ . Generally, the  $S$  value is used as a minimum sump requirement.

If the number of cycles per hour is set at 5, the last formula may be further simplified as

$$S = 0.4 P$$

The pumping rate  $P$  should be equal to or greater than the peak discharge rate from the drain system. For sump depth of more than 15 feet between on and off positions, consideration should be given to a horizontal type sump, which may be more economical.

#### (d) Economic justification of pumping plant

Frequently, a decision must be made as to whether areas protected against flooding by dikes and floodgates should be provided with a pumping plant to remove interior drainage during periods when the floodgates are closed. Such a decision cannot be made without a frequency study of precipitation and flood stage records, a determination of the project area that will be flooded without a pumping plant, and an

estimate of the resulting damages. The study required for the justification of a pumping plant should be based on a comparison of its cost against the damages expected without it.

#### (e) Pumping from subsurface aquifers

In drainage systems that require pumping from an underlying aquifer, location of the wells and pumps must be based on an extensive subsurface investigation. This investigation must determine the practicability of lowering the water table by pumping the aquifer and also determine the most suitable location for the wells to accomplish the objectives. The drainage water may be discharged either into an irrigation system or through shallow surface ditches to a drainage outlet. In either case, location of the well would be based primarily on requirements for pumping the aquifer instead of conditions for discharge of the effluent.

#### (f) Basic information required for plant design

The amount of data required varies according to specific arrangements. As a general rule, data on the following items are needed:

**Location of plant**—detailed topography and data on foundation investigations may or may not be provided.

**Pump capacity**—design removal rate less available storage.

**Maximum, minimum, and average static heads**—based on stage-frequency analysis of the outlet.

The maximum static head is the elevation of the maximum stage in the outlet minus the optimum elevation in the suction bay. Efficiency at this head may be lower than that required at the average head.

The minimum static head is the difference between the mean monthly minimum stage in the outlet and the optimum stage in the suction bay. Where multiple pumping units are required, at least one unit should have a high efficiency at this head.

The average static head is the difference between the average monthly stage in the outlet and the optimum stage in the suction bay, weighted according to the amounts of runoff to be expected for the respective months. The plant should operate at peak efficiency for this stage.

**Type, number, and size of pumps**—For low heads of up to 15 to 20 feet, the axial flow pump is recommended. For heads of up to 40 to 50 feet, the mixed flow pump is recommended. For large installations, at least two pumps should be recommended with the relative size based on operational requirements. For average conditions, one of the two pumps should have about twice the capacity of the other. A 3-unit plant gives good flexibility of operation. Sizes recommended should be based on holding velocities in the discharge pipe at 8 to 10 feet per second for the design capacity.

**Recommended start and stop elevations for each unit.**

**Schematic layout of the proposed plant**—should include suggestions for layout and appurtenant facilities. Such items as the installation of discharge pipes over dikes, trash racks, siphon breakers, equipment for automatic control of operation, and access roads should be indicated.



---

# References

---

*The references noted are not all inclusive or the only ones used to prepare chapter 14. The original document was prepared by Soil Conservation Service staff using experience from decades of observations as well as research from many sources. References were not sited in the original document and most information came from multiple sources. This revision includes some specific references where important new details have been added; however, many items are not referenced. The following list of suggested references is presented to help research particular topics if more detail is desired for a specific application.*

- Advanced Drainage Systems, Inc. 1984. Specifier manual. Columbus, OH.
- American Association of State Highway and Transportation Officials (AASHTO). Washington, DC.
- American Concrete Pipe Association. 1988. Concrete pipe handbook. Irving TX.
- American Concrete Pipe Association. 1992. Concrete pipe design manual. Irving, TX.
- American Concrete Pipe Association. 1993a. Concrete pipe technology handbook. Irving, TX.
- American Concrete Pipe Association. 1993b. Standard installations and bedding factors for the indirect design method. Design data 40, Irving, TX.
- American Iron and Steel Institute. 1971. Handbook of steel drainage and highway construction products. New York, NY
- American Society of Agricultural Engineers. 1996. Standard, engineering practice and data. 43rd ed. Engr. Practice 260.4. Design and construction of subsurface drains in humid areas. St. Joseph, MI pp. 682-692.
- American Society of Civil Engineers. 1982. Gravity sanitary sewer design and construction. Manual No. 60, Reston, VA.
- American Society of Civil Engineers. 1990. Agricultural salinity assessment and management. Manual No. 71, Reston, VA, 619 pp.
- American Society of Civil Engineers. 1992. Design and construction of urban stormwater management systems. Manual No. 77, Reston, VA.
- American Society of Civil Engineers. 1993. Standard guidelines for installation of urban subsurface drainage. ASCE 13-93, Reston, VA, 611 pp.
- American Society of Civil Engineers. 1993. Standard practice for direct design of buried precast concrete pipe using standard installations (SIDD). Designation 15-93, Reston, VA.
- American Society of Civil Engineers. 1995. Effect of agricultural drainage on water quality in humid regions. Irrigation and Drainage Journal, July - August 1995.
- American Society of Civil Engineers. 1998. Urban subsurface drainage manual of engineering. Practice No 95, Reston, VA, 190 pp.
- Bengtson, Richard L., Cade E. Carter, James L. Fouss, Lloyd M. Southwick, and Guye H. Willis. 1995. Agricultural drainage and water quality in Mississippi Delta. Irrigation and Drainage Journal, July-August 1995.
- Bouwer, H. 1978. Ground water hydrology. McGraw-Hill. New York, NY.
- Carroll, R.G. 1983. Geotextile filter criteria. Transportation research record 916, 46-53.
- Cedergren, Harry R. 1989. Seepage, drainage, and flow nets. John Wiley & Sons, Inc., New York, NY.
- Chambers, R.E., T.J. McGrath, and F.J. Heger. 1980. Plastic pipe for subsurface drainage of transportation facilities. Transportation Research Board. National Cooperative Highway Research Program Report 225, Washington, DC.
- Dierickx, W. 1992. Use of drainage materials. Vol. I, Proc. 5th International Drainage Workshop, Lahore, Pakistan.
- Dierickx, W., H. Rehman, and S. Rehman. 1992. Significant design and selection parameters for synthetic envelopes. Vol. III, Proc. 5th International Drainage Workshop, Lahore, Pakistan, pp. 5.8jj-5.17.

- Federal Register. 1993. Vol. 58. No. 9/ Thursday, January 14, 1993, Rules and Regulations. Washington, DC.
- Finck, Charles. 1997. Drainage boom. Farm Journal, July/August 1997 Issue, pp. 14-16.
- Fisher, G.R., B.R. Christopher, and R.D. Holz. 1990. Filter criteria based on pore size distribution. Proc. 4th Intl. Conf. on Geotextiles, Geomembranes, and Related Products. Vol. I, The Hague, The Netherlands, A.A. Balkema, Rotterdam, pp 289-294.
- Fogiel, Andrew, and H.W. Belcher. 1991. Research literature review of water table management impacts on water quality. Published by Agricultural Engineering Department, Michigan State University, and Land Improvement Contractors of America, East Lansing, MI, 111 pp.
- Foreign Agriculture Organization. 1988. Geographic information systems in FAO. Foreign Agriculture Organization of the United Nations, Rome, Italy, 17 pp.
- Foreign Agriculture Organization. 1997. Management guidelines for agricultural drainage and water quality. Foreign Agriculture Organization of the United Nations, Rome, Italy, 121 pp.
- Fouss J.L. 1968. Corrugated plastic drains plowed-in automatically. Transactions of ASAE, vol. 11, pp. 804-808.
- Fouss J.L., and R.C. Reeve. 1987. Advances in drainage technology: 1955-85. *In* Farm Drainage in the United States: History, Status, and Prospects, USDA Misc. Publ. No. 1455, pp. 30-47.
- Fouss J.L., N.R. Fausey, and R.C. Reeve. 1972. Draintube plows: Their operation and laser grade control. Proceedings of Second National ASAE Drainage Symposium, St. Joseph, MI, pp. 39-42.
- Fouss, J.L. 1968. Corrugated plastic drains plowed-in automatically. Transactions of ASAE. vol. 11, pp. 804-808.
- Fouss, J.L. 1974. Drain tube materials and installation. Drainage for Agriculture, Jan van Schilfgaarde (ed.), Monog. No. 17, Amer. Soc. Agrn., Madison, WI, pp. 147-177, 197-200.
- Fouss, J.L. 1982. Modernized materials handling and installation for plow-type drainage equipment. Proc. Second Intl. Drainage Workshop, Washington, DC, pp 41-51.
- Fouss, J.L., and Altermatt. 1982. Drainage-plow boot design to improve installations of corrugated plastic tubing. Proc. Fourth National Drainage Symposium, ASAE Pub. No. 12-82, pp. 102-104.
- Giroud, J.P. 1982. Filter criteria for geotextiles. Proc. 2nd International Conference on Geotextiles, Las Vegas, NV, Vol. 1:103-108.
- Hancor, Inc. 1991. Drainage handbook. Findlay, OH.
- Hancor, Inc. 1993. Recommended installation practice for Hancor Hi-Q, Hi-Q *Sure-Lok*, TiteLine, heavy duty and heavy duty. AASHTO Pipe, Findlay, OH.
- Hore, F.R., R.W. Irwin, B.C. Mathews, and F.J. Parrish. 1960. Drainage guide for Ontario. Dep. Eng. Sci., Ontario Agr. Col. Pub. 29, 24 pp.
- International Standards Organization. 1990. Geotextiles - vocabulary first edition. ISO 10318.
- International Standards Organization. 1988. Textiles, nonwoven, definition first edition. ISO 9092.
- Jacobsen, S.M., R. Wayne Skaggs. 1997. Lateral effect: what's known and unknown. 1997 ASAE International Meeting, Minneapolis, MN, August 10-14, ASAE, St. Joseph, MI, 9 pp.
- Kirkham, D. 1949. Flow of ponded water into drain tubes in soil overlying an impervious layer. Amer. Geophys. Union Trans. 30(3).
- Koerner, R.M. 1986. Designing with geosynthetics. Second edition.
- Luthin, J.N., G.S. Taylor, and C. Prieto. 1968. Exit gradients into subsurface drains. Hilgardia 39(15):419-428.

- Marston, A. 1930. The theory of external loads on closed conduits in the light of the latest experiments. Bulletin 96, Iowa State Col., Ames, IA.
- Marston, A., W.J. Schlick, and H.F. Clemmer. 1917. The supporting strength of sewer pipe in ditches and methods of testing sewer pipe in laboratories to determine their ordinary supporting strength. Bulletin 47. Iowa State Col., Ames, IA.
- National Clay Pipe Institute. 1982. Clay pipe engineering manual. Washington, DC.
- Prieto, C.K. 1967. Study of factors influencing a quick condition in foundation sand. M.S. thesis, Dep. Civil Eng., Univ. California, Davis.
- Salem, H.E., and L.S. Willardson. 1992. Evaluation of nonstandard synthetic envelope materials. Vol. I, Proc. 5th Intl. Drain. Symp., Lahore, Pakistan.
- Samani, and L.S. Willardson. 1981. Soil hydraulic stability in a subsurface drainage system. Trans. Amer. Soc. Agr. Eng., Vol 24, No. 3, pp. 666-669.
- Schlick, W.J. 1932. Loads on pipe in wide ditches. Bul. 108, Iowa State Col., Ames, IA.
- Sherard, J.L., L.P. Dunnigan, and J.R. Talbot. 1984a. Basic properties of sand and gravel filters. J. Geotech. Eng., Vol. 110, No. 6, June, 1984, Amer. Soc. Civil Eng., pp. 684-700.
- Sherard, J.L., L.P. Dunnigan, and J.R. Talbot. 1984b. Filters for silts and clays. J. Geotech. Eng., Vol. 110, No. 6, June, 1984, Amer. Soc. Civil Eng., pp. 701-718.
- Spangler, M.G. 1933. The supporting strength of rigid pipe culverts. Bul. 112, Iowa State Col., Ames, IA.
- Spangler, M.G. 1950. Field measurements of the settlement ratios of various highway culverts. Bul. 170, Iowa State Col., Ames, IA.
- Studebaker, D.C. 1971. The laser plane system. Agric. Eng.. Vol. 53, No. 8. pp. 418-419.
- Stuyt, L.C.P.M. 1992a. The water acceptance of wrapped subsurface drains. Ph.D. thesis, Agric. Univ., The Winand Staring Centre (SC-DLO), Wageningen, The Netherlands.
- Stuyt, L.C.P.M. 1992b. Mineral clogging of wrapped subsurface drains installed in unstable soils: a field study. Vol. III, Proc. 5th Intl. Drain Symp., Lahore, Pakistan.
- Teach, T.L. 1972. Automatic laser grade controls. SAE Earthmoving Industry Conf., Central Illinois Section, Peoria, April 10-12. Pap. No. 720386.
- The World Bank. 1992. Drainage guidelines. World Bank Technical Paper No. 195, Washington, DC, 186 pp.
- Uni-Bell PVC Pipe Association. 1986. Handbook of PVC pipe: design and construction. Dallas, TX.
- Uni-Bell PVC Pipe Association. 1991. Handbook of PVC pipe. Dallas, TX.
- United States Army Corps of Engineers. 1941. Investigation of filter requirements for underdrains. Waterways Exp. Sta., Tech. Memo. 183-1, 35 pp.
- United States Department of Agriculture. 1987. Farm drainage in the United States, history, status, and prospects. Misc. Pub. 1455, Econ. Res. Serv., Washington, DC.
- United States Department of Agriculture. 1994. DRAINMOD user's guide. Natural Resource Conserv. Serv., Washington, DC, 130 pp.
- United States Department of the Interior, Bureau of Reclamation. 1993. Drainage manual. Denver Federal Center, Denver, CO.
- van Beers, W.F.J. 1979. Nomographs for the calculation of drain spacings. Intl. Inst. Land Reclamation and Improvement, Water Resource Publications, Highland Ranch, CO.
- van Beers, W.F.J. 1983. The auger hole method. Intl. Inst. Land Reclamation and Improvement, Water Resource Publications, Highland Ranch, CO.

Walesh, Stuart G. Urban surface water management.  
John Wiley & Sons, Inc.

Walker, G.M. 1984. Rehabilitation of a calcium carbonate clogged drainage system using sulfamic acid. REC-ERC-85-2.

Willardson, L.S., and R.E. Walker. 1979. Synthetic drain envelope soil interactions. Proc. Irrig. and Drain. Div. Vol. 105, No. IR4, Amer. Soc. Civil Eng., pp. 367-373.

Zucker, L.A. and L.C. Brown (Eds.). 1998. Agricultural drainage: water quality impacts and subsurface drainage studies in the midwest. OH State Univ., Extension Bulletin 871, Columbus, OH.



---

# Glossary

---

*The glossary defines some of the specific terms used in this chapter. The listing is not intended to be complete, but should assist in providing a quick reference to many terms that may not be commonly understood.*

- AASHTO** American Association of State Highway Transportation Officials.
- ACPA** American Concrete Pipe Association, Irving, TX.
- AOS** Apparent opening size of geotextiles expressed in sieve size or millimeters, sometimes referred to as EOS (effective opening size). The property that indicates approximate largest particle that would pass through a geotextile. AOS  $O_{95}$  is the size at which 95 percent of the openings in the geotextile are smaller.
- Aquifer** A geologic formation that holds and yields useable amounts of water. Aquifers can be classified as confined or unconfined.
- Artesian aquifer** Aquifer that contains water under pressure as a result of hydrostatic head. For artesian conditions to exist, an aquifer must be overlain by a confining material of aquiclude and receive a supply of water. The free water surface stands at a higher elevation than the top confining layer.
- ASTM** American Society for Testing and Materials.
- Backfilling (drainage)** The replacement of the excavated material after drain placement and blinding or envelope installation.
- Base drainage system** A permeable drainage blanket under a roadway.
- Bedding** (1) A surface drainage method accomplished by plowing land to form a series of low narrow ridges separated by parallel dead furrows. The ridges are oriented in the direction of the greatest land slope (crowning or ridging). (2) Preparation of furrow-irrigated rowcropped field with wide, flattened ridges between furrows on which one or more crop rows are planted. (3) The process of laying a pipe or other conduit in a trench with the bottom shaped to the contour of the conduit or tamping earth around the conduit to form its bed. The manner of bedding may be specified to conform to the earth load and conduit strength. (4) Material placed under a pipe or other conduit for mechanical support.
- Bedding angle** The acute angle of a V-groove in the bottom of a trench for support of pipe drains.
- Bedding ditch** A dead furrow used as a surface drainage ditch in a bedding system.
- Berm** (1) Strip or area of land, usually level, between the edge of spoil bank and edge of a ditch or canal. (2) A small embankment or ridge for controlling surface waterflow.

---

|                                       |  |
|---------------------------------------|--|
| <b>Best management practice (BMP)</b> | Structural, nonstructural, and managerial techniques recognized to be the most effective and practical means to reduce surface and ground water contamination while still allowing the productive use of resources.                                    |
| <b>Blind drain</b>                    | Type of drain consisting of an excavated trench, refilled with pervious materials (coarse sand, gravel, or crushed stones) through whose voids water percolates and flows toward an outlet (also called a trench drain).                               |
| <b>Blind inlet</b>                    | Surface water inlet to a drain in which water enters by percolation rather than through open flow conduits.  |
| <b>Blinding</b>                       | Material placed on top of and around a drain tile or conduit to improve the flow of water to the drain and to prevent displacement backfilling of trench.  |
| <b>Buffer strip</b>                   | A strip of grass or other close-growing perennial vegetation that separates a watercourse from an intensive land use area to prevent sediment entry into drainage channels (preferred term is filter strip).   |
| <b>Bullet (drainage)</b>              | Round-nosed cylindrical point of a mole drain plow which forms a cavity as the plow is drawn through the soil (also referred to as a torpedo).   |
| <b>Bypass ditch</b>                   | A waterway for carrying water from a drainage area directly to a gravity outlet, bypassing any pumping plants.   |
| <b>Capillary fringe</b>               | A zone in the soil just above the water table that remains saturated or almost saturated. The extent depends upon the size-distribution of pores.  |
| <b>Capillary pressure head</b>        | Height water will rise by surface tension above a free water surface in the soil, expressed as length unit of water. Sometimes called <i>capillary rise</i> .  |
| <b>Capillary soil moisture</b>        | Preferred term is soil-water potential.  |
| <b>Centrifugal pump</b>               | Pump consisting of rotating vanes (impeller) enclosed in a housing and used to impart energy to a fluid through centrifugal force.   |
| <b>Chain trencher</b>                 | An excavator that uses a chain with cutters attached to cut, remove, and deposit spoil to the side of the trench or on to a discharge conveyor.  |
| <b>Channel capacity</b>               | Flow rate in a ditch, canal, or natural channel when flowing full or at design flow.   |
| <b>Channel storage drainage</b>       | The volume of water that can be stored above the start pumping level in ditches or floodways without flooding cropland.  |
| <b>Check drain</b>                    | Conventional drain altered by use of checks so that it can be used as a subirrigation system.  |
| <b>Chimney drain</b>                  | Subsurface interceptor drain frequently used in dams, embankments, and similar construction to control seepage within the earthen structure. Chimney drains are constructed in near vertical orientation and discharge to outlets at lower elevations. |

---

|  |   |
|--|---|
| <b>Clay</b>                            | A soil separate consisting of particles less than 2 $\mu\text{m}$ in equivalent diameter.   |
| <b>Clay tile</b>                       | Short lengths of pipe used for subsurface drains. The pipe is made from shale or clay.  |
| <b>Claypan</b>                         | A dense, compact layer in the subsoil having a much higher clay content than the overlying material, separated by a sharply defined boundary. Claypans are usually hard when dry, and plastic and sticky when wet. Also, they usually impede the movement of water and air and the growth of plant roots. |
| <b>Closed drain</b>                    | Subsurface drain, tile, or perforated pipe, which may also receive surface water through surface inlets (no longer in common use).  |
| <b>Colloidal fines</b>                 | Clay particles smaller than two microns.  |
| <b>Colloids</b>                        | Negatively charged soil particles smaller than 1 $\mu\text{m}$ in diameter.   |
| <b>Cone of depression or influence</b> | The water table or piezometric surface, roughly conical in shape, produced by the extraction of water from a well.  |
| <b>Confined aquifer</b>                | An aquifer whose upper, and perhaps lower, boundary is defined by a layer of natural material that does not transmit water readily.   |
| <b>Controlled drainage</b>             | Regulation of the water table by means of control dams, check drains, or a combination of these, for maintaining the water table at a depth favorable to crop growth.   |
| <b>Conveyance loss</b>                 | Loss of water from a channel or pipe during transport, including losses caused by seepage, leakage, evaporation, and transpiration by plants growing in or near the channel.  |
| <b>Corrugated plastic pipe</b>         | Extruded plastic pipe with a corrugated wall and, when perforated, used for subsurface drains.  |
| <b>CMP</b>                             | Corrugated metal pipe.  |
| <b>CPE pipe</b>                        | Corrugated polyethylene drain pipe.   |
| <b>CPP</b>                             | Corrugated plastic pipe.  |
| <b>Crack width</b>                     | Space between the ends of adjacent clay or concrete drain tile.   |
| <b>Cradle</b>                          | A support made of rigid material, such as concrete, wood, or steel, used in unstable soil to maintain grade, support tile or tubing, and prevent deflection of the tubing.  |
| <b>Critical depth</b>                  | Depth of flow in a channel at which specific energy is a minimum for a given discharge.   |

---

|                              |  |
|------------------------------|--|
| <b>Critical velocity</b>     | Flow velocity at which a given discharge changes from tranquil to rapid or rapid to tranquil. That velocity in an open channel for which the specific energy is a minimum for a given discharge.                             |
| <b>Cross slope</b>           | Slope of a field, measured at right angles to the row direction.   |
| <b>Crowning</b>              | The process of forming the surface of land into a series of broad, low ridges, separated by parallel field drains.   |
| <b>Cutoff drain</b>          | See Interceptor drain.   |
| <b>Darcy's law</b>           | A concept formulated by Henry Darcy in 1856 to describe the rate of flow of water through porous media. The rate of flow of water in porous media is proportional to the thickness of the bed and to the hydraulic gradient. |
| <b>Dead load</b>             | A permanent load; a load that is constant in magnitude and position, usually for the design life.  |
| <b>Deep percolation</b>      | Water that moves downward through the soil profile below the root zone and is unavailable for use by plants.   |
| <b>Deflection</b>            | The change in the vertical inside diameter of a pipe caused by applied loads.  |
| <b>Diversion</b>             | A channel or dam constructed across a slope to intercept surface runoff and divert it to a safe or convenient discharge point. Usually placed above the area to be protected.  |
| <b>Double ditch or drain</b> | See W-ditch.   |
| <b>Double-main system</b>    | Gridiron layout of subsurface drains with two closely spaced parallel main conduits.   |
| <b>Drain</b>                 | Any closed conduit (perforated tubing or tile) or open channel used for removal of surplus ground or surface water.  |
| <b>Drain inlet structure</b> | See Surface inlet.   |
| <b>Drain plow</b>            | A machine with a vertical blade, chisel point, and shield or boot used to install corrugated plastic tubing or drain tile.   |
| <b>Drain tile</b>            | Short length of pipe made of burned clay, concrete, or similar material, usually laid with open joints, to collect and remove subsurface water.  |
| <b>Drainable water</b>       | Water that readily drains from soil under the influence of gravity.  |
| <b>Drainage</b>              | Process of removing surface or subsurface water from a soil or area.   |
| <b>Drainage basin</b>        | The area from which runoff is collected and delivered to an outlet.  |

---

|                                |  |
|--------------------------------|--|
| <b>Drainage coefficient</b>    | Rate at which water is to be removed from a drainage area, expressed as depth per day or flow rate per unit of area. Sometimes called <i>drainage modulus</i> .  |
| <b>Drainage curves</b>         | Flow rate versus drainage area curves giving prescribed rates of runoff for different levels of crop protection.   |
| <b>Drainage pattern</b>        | (1) Arrangement of a system of surface or subsurface drains. (2) Arrangement of tributaries within a watershed.  |
| <b>Drainage pumping plant</b>  | Pumps, power units, and appurtenances for lifting drainage water from a collecting basin to an outlet.   |
| <b>Drainage system</b>         | Collection of surface and/or subsurface drains, together with structures and pumps, used to remove surface or ground water.  |
| <b>Drainage well</b>           | (1) A well pumped to lower water table. (2) Vertical shaft to a permeable substratum into which surface and subsurface drainage water is channeled (now illegal).  |
| <b>Drawdown</b>                | (1) Lowering of the water surface, water table, or piezometric surface resulting from the withdrawal of water from a well or drain. (2) Elevation of the static water level in a well minus the elevation of the pumping water level (at the well) at a given discharge rate (see Cone of depression).   |
| <b>Drop structure</b>          | Hydraulic structure for safely transferring water in a channel to a lower level channel without causing erosion.   |
| <b>Electrical conductivity</b> | A measure of the ability of water to conduct electricity, which is used to estimate the amount of soluble salts in irrigation or drainage water, or solution extract of a soil.  |
| <b>Envelope</b>                | <b><i>Drain envelope</i></b> —Generic name for materials placed on or around a drainage conduit, irrespective of whether used for mechanical support, hydraulic purposes (hydraulic envelope), or to stabilize surrounding soil material (filter envelope).<br><b><i>Hydraulic envelope</i></b> —Permeable material placed around a drainage conduit to improve flow conditions in the area immediately adjacent to the drain.<br><b><i>Filter envelope</i></b> —Permeable material placed around a drainage conduit to enhance water entry and stabilize the structure of the surrounding soil material. A filter envelope may initially allow some fines and colloidal material to pass through it and into the drain. |
| <b>Estuarine inflows</b>       | The freshwater input necessary to provide nutrient input, sediment movement, circulation, and maintenance of brackish conditions for estuarine organisms.  |
| <b>Evapotranspiration</b>      | The combination of water transpired from vegetation and evaporated from the soil and plant surfaces.   |

---

|                                       |   |
|---------------------------------------|---|
| <b>Exchange capacity</b>              | The total ionic charge of the absorption complex active in the adsorption of ions.  |
| <b>Exchangeable cation</b>            | A positively charged ion held on or near the surface of a solid particle by a negative surface charge of a colloid and which may be replaced by other positively charged ions in the soil solution.                               |
| <b>Exchangeable sodium percentage</b> | The fraction of the cation exchange capacity of a soil occupied by sodium ions.   |
| <b>Field capacity</b>                 | Amount of water remaining in a soil when the downward water flow caused by gravity becomes negligible.  |
| <b>Field ditch</b>                    | A ditch constructed within a field either for irrigation or drainage.   |
| <b>Field drain</b>                    | A shallow-graded channel, usually having relatively flat side slopes, that collects surface water within a field.   |
| <b>Field lateral (drainage)</b>       | The principal ditch for draining adjacent fields or areas on a farm. Field laterals receive water from row drains, field drains, and field surfaces and carry it to drainage outlet channels.                                     |
| <b>Filter strip</b>                   | Permanent vegetated strip between fields and receiving water or runoff conveyance structures to retard surface runoff and remove sediment, nutrients, or other contaminants from surface runoff.                                  |
| <b>Fin drain</b>                      | A group of geocomposite drains designed with interior drainage paths to remove relatively large quantities of subsurface drainage water.  |
| <b>Finishing shoe</b>                 | A mechanism attached to or part of excavating equipment that shapes the bottom of a trench and may convey drain tile or tubing to the bottom of the trench (also known as crummer, boot, tile/tubing chute, trench cleaner shoe). |
| <b>Flashboard</b>                     | Wood plank, generally held horizontally in vertical slots on the crest of a dam or check structure to control the upstream water level. Commonly called stoplog.  |
| <b>Float valve</b>                    | A valve, actuated by a float, that automatically controls the flow of water.  |
| <b>Floating beam drain plow</b>       | A drain plow in which the installed pipe's depth and grade are controlled by the pitch of the shank and finishing shoe.   |
| <b>Flood control</b>                  | Methods or facilities for controlling flood flows.  |
| <b>Flood gate</b>                     | Mechanical gate to prevent backflow into a closed conduit during high water stages. Sometimes called <i>drainage gate</i> .   |
| <b>Flow line</b>                      | Lowest level of flow in a conduit or channel.   |

---

|                       |  |
|-----------------------|--|
| <b>Forced outlet</b>  | Basin or box outlet for a pipe drain in which the discharge will fill the basin and flow away over the ground surface. Used where a freefall outlet is not available.  |
| <b>Forebay</b>        | Reservoir or pond at the intake of a penstock, pipeline, or pump station.  |
| <b>Free discharge</b> | Discharge of water from a conduit into the atmosphere without back pressure.   |
| <b>Free flow</b>      | Flow through or over a structure without back pressure.  |
| <b>Freeboard</b>      | Vertical distance between the maximum water surface elevation anticipated in design and the top of retaining banks, pipeline vents, or other structures, provided to prevent overtopping because of unforeseen conditions.   |
| <b>French drain</b>   | An excavated trench refilled with pervious materials through whose voids water flows toward an outlet (preferred term is <i>blind drain</i> ).   |
| <b>Friction head</b>  | Energy required to overcome friction caused by fluid movement relative to the boundaries of a conduit or containing medium.  |
| <b>Friction slope</b> | Friction head loss per unit length of conduit.   |
| <b>Frost action</b>   | Freezing and thawing of moist soil.  |
| <b>Frost depth</b>    | The depth to which a soil will freeze.   |
| <b>Gap graded</b>     | A gravel or soil with a significant range of particle sizes missing.   |
| <b>Gate</b>           | A device used to control the flow of water to, from, or in a pipeline, or open channel. It may be opened and closed by screw action, slide action, or hydraulic or pneumatic actuators.                                      |
| <b>Geocomposite</b>   | Geosynthetic materials for collecting and transporting water while maintaining soil stability.   |
| <b>Geomembrane</b>    | Sheet material intended to form an impervious barrier.   |
| <b>Geosynthetic</b>   | Synthetic material or structure used as an integral part of a project, structure, or system. Within this category are subsurface drainage and water control materials, such as geomembranes, geotextiles, and geocomposites. |
| <b>Geotextile</b>     | A woven or nonwoven thermoplastic sheet material intended to allow the passage of water, but not fines, and without collecting fines at the soil-textile interface.  |
| <b>Grade</b>          | (noun) Slope of a road, channel, or ground surface. (verb) To finish the surface of a canal bed, roadbed, top of embankment, or bottom of excavation.  |

---

|                                    |  |
|------------------------------------|--|
| <b>Grade breaker</b>               | A special mechanical device attached to an earthmoving machine to change the normal gradeline.   |
| <b>Grade control</b>               | The process of maintaining constant and correct slope of a trench, ditch, terrace, canal, etc., using optical or laser surveying equipment.  |
| <b>Gradeline</b>                   | A line established as a construction reference for ditches, terraces, etc.   |
| <b>Grade stabilizing structure</b> | Structure used to control the bottom grade of a channel.   |
| <b>Grated inlet</b>                | A specific type of surface inlet to a pipe drain protected with a grate.   |
| <b>Gravitational water</b>         | Soil water that moves into, through, or out of the soil under the influence of gravity (preferred term is <i>soil-water potential</i> ).   |
| <b>Gravity flow</b>                | Water flow that is not pumped, but flows because of the acceleration forces of gravity. Used in irrigation, drainage, inlets, and outlets.   |
| <b>Ground water</b>                | Water occurring in the zone of saturation in an aquifer or soil.   |
| <b>Ground water flow</b>           | Flow of water in an aquifer or soil. That part of the stream discharge that is derived from ground water.  |
| <b>Hardpan (soil)</b>              | A hardened soil layer, in the lower A or B horizon, caused by cementation of soil particles.   |
| <b>Head</b>                        | The energy in the liquid system expressed as the equivalent height of a water column above a given datum.  |
| <b>Herringbone system</b>          | Arrangement of a pipe drainage system where laterals enter a main from both sides at angles less than 90 degrees.  |
| <b>Humid climates</b>              | Climate characterized by high rainfall and low evaporation potential. A region is usually considered as humid when precipitation averages more than 500 mm (20 in) per year.   |
| <b>Hydraulic conductivity</b>      | The ability of a porous medium to transmit a specific fluid under a unit hydraulic gradient; a function of both the characteristics of the medium and the properties of the fluid being transmitted. Usually a laboratory measurement corrected to a standard temperature and expressed in units of length/time. Although the term hydraulic conductivity is sometimes used interchangeably with the term permeability (water), the user should be aware of differences. |
| <b>Hydraulic efficiency</b>        | (1) Efficiency with which a pump imparts energy to water or a turbine extracts energy from water. (2) A measure of the loss of energy when water flows through a hydraulic structure.  |
| <b>Hydraulic gradient</b>          | Change in the hydraulic head per unit distance.  |



---

|                                   |  |
|-----------------------------------|--|
| <b>Hydraulic radius</b>           | Cross-sectional area of a fluid stream of conduit divided by its wetted perimeter (length of its conduit surface in contact with fluid).                             |
| <b>Hydrological profile</b>       | The profile of hydraulic conductivity values for soil layers or horizons located below the water table.  |
| <b>Hydrology</b>                  | Science dealing with water of the world, including distribution, and cycle in nature.  |
| <b>Impermeable barrier layer</b>  | A soil stratum with a permeability less than 10 percent of the soil permeability between the layer and the groundwater surface.                                      |
| <b>Infiltration</b>               | The downward entry of water through the soil surface into the soil.  |
| <b>Infiltration rate</b>          | The quantity of water that enters the soil surface in a specified time interval. Often expressed in volume of water per unit of soil surface area per unit of time.  |
| <b>Inlet</b>                      | (1) An appurtenance to deliver water to a pipeline system. (2) Point of defined inflow into a conduit or channel.  |
| <b>Innerflow</b>                  | Having hydraulic flow capability in all directions within a strata or layer of material.   |
| <b>Instream flow requirements</b> | The flow regime necessary to provide for the combined needs of fish, wildlife, recreation, navigation, hydropower production, and downstream conveyance in a stream. |
| <b>Intake</b>                     | (1) Head-works of a conduit. (2) The place of diversion. (3) Water infiltration into soil.   |
| <b>Interception</b>               | That portion of precipitation caught by vegetation and prevented from reaching the soil surface.   |
| <b>Interceptor drain</b>          | A channel located across the flow of ground water and installed to collect subsurface flow before it resurfaces. Surface water is also collected and removed.        |
| <b>Interflow</b>                  | Water that infiltrates into the soil and moves laterally through the upper soil horizons until it returns to the surface, often in a stream channel.                 |
| <b>Intermittent stream</b>        | Natural channel in which water does not flow continuously.   |
| <b>Internal drainage</b>          | Drainage of the soil profile; may be either natural or constructed.  |
| <b>Intrinsic permeability</b>     | The property of a porous material that expresses the ease with which gases or liquids flow through it (see Permeability).  |
| <b>Invert</b>                     | Lowest element of the internal cross section of a channel or pipe.   |

---

|                          |   |
|--------------------------|---|
| <b>Iron ochre</b>        | A reddish or yellowish brown gelatinous deposit formed by iron fixing bacteria. The gelatinous material hardens into a scale deposit with age.  |
| <b>Isotropic (soil)</b>  | The condition of a soil or other porous media when physical properties, particularly hydraulic conductivity, are equal in all directions.   |
| <b>Joint spacing</b>     | Width of gap between adjacent rigid drain tiles through which water enters from the surrounding soil.   |
| <b>Joint wrapping</b>    | Placement of porous material over or around the pipe joints of subsurface drains to help prevent inflow of sediment.  |
| <b>Junction</b>          | (1) Point of intersection of two drains. (2) Accessory used to create a connection between two pipelines.   |
| <b>Junction box</b>      | Box, manhole, or other structure that serves to join two or more pipes.   |
| <b>Keel</b>              | Longitudinal strip attached at the center bottom of the shoe of a trenching machine to form the trench bottom.  |
| <b>Laminar flow</b>      | Flow in which there are no cross currents or eddies and where the fluid elements move in approximately parallel directions. Flow through granular material is usually laminar. Sometimes called <i>streamline</i> or <i>viscous flow</i> .  |
| <b>Land capability</b>   | Classification of soil units for the purpose of showing their relative suitability for specific uses, such as crop production with minimum erosion hazard.  |
| <b>Land leveler</b>      | A machine with a long wheel base used for land smoothing or leveling operations.  |
| <b>Land leveling</b>     | Process of shaping the land surface to a level surface. A special case of land grading.   |
| <b>Land smoothing</b>    | Shaping the land to remove irregular, uneven, mounded, broken, and jagged surfaces without using surveying information.   |
| <b>Land use planning</b> | Development of plans for the use of land that will, over a long period, best serve the interest of the general public.  |
| <b>Landgrading</b>       | The operation of shaping the surface of land to predetermined grades so each row or surface slopes to a drain or is configured for efficient irrigation water applications. Also called <i>land forming</i> or <i>land shaping</i> (see <b>Land leveling</b> for a special case).                     |
| <b>Laser leveling</b>    | Land leveling in which a stationary laser transmitter and a laser receiver on each earthmoving machine are used for grade control.  |
| <b>Laser receiver</b>    | An electronic device normally mounted on earthmoving machines, survey rods, or trenchers that receives signals from a laser transmitter and indicates to the operator or sends signals to control points on the machine to adjust the machine to follow the slope established by a laser transmitter. |

---

|                                     |   |
|-------------------------------------|---|
| <b>Laser transmitter</b>            | A device that generates the collimated laser light beam.  |
| <b>Lateral</b>                      | Secondary or side channel, ditch, or conduit. Also called <i>branch drain</i> or <i>spur</i> .  |
| <b>Leaching</b>                     | Removal of soluble material from soil or other permeable material by the passage of water through it.   |
| <b>Leaching fraction</b>            | The ratio of the depth of subsurface drainage water (deep percolation) to the depth of infiltrated irrigation water (see leaching requirement).   |
| <b>Leaching requirement</b>         | Quantity of irrigation water required for transporting salts through the soil profile to maintain a favorable salt balance in the root zone for plant development.  |
| <b>Live load</b>                    | A load that changes in magnitude and/or direction during the project design life.   |
| <b>Longitudinal drainage system</b> | A drainage system parallel to a roadway, runway, or other structural component.   |
| <b>Longitudinal smoothing</b>       | Land smoothing operation where all soil movement is done parallel to crop row direction for the purpose of obtaining a grade.   |
| <b>Mole drain</b>                   | Drain formed by pulling a vertical blade and a bullet-shaped cylinder through the soil.   |
| <b>Normal depth</b>                 | Depth of flow in an open channel during uniform flow for the given conditions.  |
| <b>O&amp;M</b>                      | Operation and maintenance.  |
| <b>Observation well</b>             | Hole bored to a desired depth below the ground surface for observing the water table level.   |
| <b>Open ditch outlet</b>            | Excavated open channel for disposing of drainage water from a surface or subsurface drainage system, or for carrying flood water.   |
| <b>OSHA</b>                         | Occupational Safety and Health Administration, the Federal agency responsible for safety and health concerns.   |
| <b>Outfall</b>                      | Point where water flows from a conduit, stream, or drain.   |
| <b>Outlet</b>                       | (1) An appurtenance to deliver water from a pipe system to the land, an individual sprinkler, lateral of sprinklers, or any surface pipe system. An outlet may consist of a valve, a riser pipe, and/or an outlet gate. (2) Point of water disposal from a stream, river, lake, tidewater, artificial drain, terrace, waterway, or diversion. |
| <b>Outlet channel</b>               | Channel constructed primarily to carry water from manufactured structures, such as terraces, subsurface drains, surface ditches, and diversions.  |

---

|                                    |  |
|------------------------------------|--|
| <b>Outlet gate</b>                 | A valve, usually a slide valve, that controls the flow of water from an outlet.  |
| <b>Parallel drainage system</b>    | A drainage system with parallel laterals or field ditches that are perpendicular to the row drains.  |
| <b>Particle-size analysis</b>      | Determination of the various amounts of the different separates in a soil sample, usually by sedimentation, sieving, or micrometry.  |
| <b>Perched water table</b>         | A localized condition of free water held in a pervious stratum because of an underlying impervious stratum and separated from deeper aquifers.   |
| <b>Percolating water</b>           | Subsurface water that flows through the soil or rocks (see Seepage).   |
| <b>Percolation</b>                 | Downward movement of water through the soil profile or other porous media.   |
| <b>Percolation rate</b>            | The rate at which water moves through porous media, such as soil.  |
| <b>Perforated pipe</b>             | Pipe designed to discharge or accept water through small, multiple, closely spaced orifices placed in its circumference.   |
| <b>Permeability</b>                | (1) (qualitative) The ease with which gases, liquids, or plant roots penetrate or pass through a layer of soil or porous media. (2) (quantitative) The specific soil property designating the rate at which gases and liquids can flow through the soil or porous media. |
| <b>Permeameter</b>                 | Device for containing the soil sample and subjecting it to fluid flow to measure permeability or hydraulic conductivity.   |
| <b>Permissible velocity</b>        | Highest water velocity in a channel or conduit that does not cause erosion.  |
| <b>Permittivity</b>                | A measure of the ability of a geotextile to permit waterflow perpendicular to its plane. (The volumetric flow rate of water per unit cross-sectional area per unit head.)  |
| <b>Phreatic surface</b>            | The level of zero (atmospheric) pressure at water table surface.   |
| <b>Piezometer</b>                  | Tube for measuring the combined elevation and pressure head or potential of a fluid.   |
| <b>Piezometric head</b>            | Combined elevation and pressure head as measured from a reference plane (see Static head).   |
| <b>Piezometric line or surface</b> | Line or surface having equal piezometric head.   |
| <b>Pipe drain</b>                  | Any circular subsurface drain, including corrugated plastic pipe and concrete or clay tile.  |
| <b>Pipe drainage system</b>        | Random, systematic or interceptor layout of subsurface drains, including the outlet, drain lines, and related structures.  |

---

|                                 |   |
|---------------------------------|---|
| <b>Pipe or tile depth</b>       | Vertical distance from the soil surface to the gradeline or bottom (invert) of a pipe or drain tile.  |
| <b>Pipe stretch</b>             | Associated with corrugated plastic pipe. Pipe strength is reduced if the pipe is installed in a stretched condition.  |
| <b>Pore size index</b>          | The characteristic pore opening size, expressed in mm or sieve size, of a geotextile where 90 percent of the openings in the geotextile are smaller (the $O_{90}$ value).   |
| <b>Porosity</b>                 | (1) (aquifer) The sum of the specific yield and the specific retention. (2) (soil) The volume of pores in a soil sample divided by the combined volume of the pores and the soil of the sample.   |
| <b>Pre-ripping</b>              | The practice of making a pass with a drain plow without installing tubing to locate any rocks and to reduce draft. Typically, the pre-ripping depth is somewhat less than the installation depth.   |
| <b>Preferential flow</b>        | Flow into and through porous media or soil by way of cracks, root holes, and other paths of low resistance rather than uniformly through the whole media.   |
| <b>Pump drainage</b>            | Drainage system in which pumps are used to lift water into an outlet.   |
| <b>Pump efficiency</b>          | Ratio of the water power produced by the pump to the power delivered to the pump by the power unit.   |
| <b>Pump submergence</b>         | Vertical distance between surface of the water supply and the inlet of the pump.  |
| <b>Pumped well drain</b>        | Well drilled into an aquifer that is pumped to lower the water table.   |
| <b>Pumping plant or station</b> | A complete installation of one or more pumps together with all necessary appurtenances, such as power units, sumps, screens, valves, motor controls, motor protection devices, fences, and shelters.  |
| <b>Quick condition</b>          | Condition in which water flows through the soil material (upward or horizontally) with sufficient velocity to significantly reduce the bearing capacity of the material through a decrease in intergranular pressure. Sometimes called <i>quicksand</i> . |
| <b>Radial flow</b>              | (1) Flow from a source or to a sink along radial lines. (2) Direction of flow in a centrifugal pump.  |
| <b>Radial-flow pump</b>         | A centrifugal pump that uses diffuser vanes to transform the velocity head into pressure head. Commonly called a <i>turbine pump</i> .  |
| <b>Radius of influence</b>      | Maximum distance from a well at which drawdown is significant (see Cone of depression).   |
| <b>Rainfall intensity</b>       | Rate of rainfall for any given time interval, usually expressed in units of depth per time.   |

---

|                                   |  |
|-----------------------------------|--|
| <b>Random drainage system</b>     | Surface or subsurface drainage system of irregular pattern used on depression topography.  |
| <b>Receiving water</b>            | Distinct bodies of water, such as streams, lakes, or estuaries, that receive runoff or wastewater discharge.   |
| <b>Recharge</b>                   | Process by which water is added to the zone of saturation to replenish an aquifer.   |
| <b>Recharge area</b>              | Land area over which water infiltrates and percolates downward to replenish an aquifer. For unconfined aquifers, the area is essentially the entire land surface overlaying the aquifer and for confined aquifers, the recharge area may be a part of or unrelated to the overlaying area. |
| <b>Rectangular weir</b>           | A channel structure having a rectangular flow notch.   |
| <b>Relief drain system</b>        | A system of subsurface drain tiles or tubing, installed within an area having a high water table, to lower the water table or maintain it at a given level.  |
| <b>Relief drain</b>               | Any product or construction that accelerates the removal of drainable subsurface water to lower a water table.   |
| <b>Relief well</b>                | Shallow well, pit, or bore to relieve hydrostatic pressure by allowing waterflow from a confined aquifer or from saturated soil.   |
| <b>Resistance coefficient</b>     | A quantitative expression of hydraulic resistance exerted by a conduit boundary on fluid flow. Examples are <b>n</b> , <b>C</b> , and <b>f</b> in the Manning, Chezy, and Darcy-Weisbach equations for velocity of uniform flow (also called <i>roughness coefficient</i> ).               |
| <b>Resource management system</b> | A combination of conservation practices and management identified by land and water uses that, when implemented, prevents resource degradation and permits sustained use of soil, water, air, plants, and animal resources.  |
| <b>Riverside drain</b>            | Drain adjacent to a riverbed to a point downstream where water can be discarded above the mean high water level of the river.  |
| <b>Root zone</b>                  | Depth of soil that plant roots readily penetrate and in which the predominant root activity occurs.  |
| <b>Roughness coefficient</b>      | See Resistance coefficient.  |
| <b>Row drain</b>                  | A small drain constructed with a plow or similar tillage implement to provide drainage into field drains or field laterals. Sometimes locally called <i>plow drain</i> , <i>quarter drain</i> , <i>header ditch</i> , or <i>annual drain</i> .   |
| <b>Runoff</b>                     | The portion of precipitation, snowmelt, or irrigation that flows over the soil, eventually making its way to surface water supplies.   |
| <b>Runoff coefficient</b>         | Ratio of peak runoff rate to rainfall intensity.   |

---

|                              |   |
|------------------------------|---|
| <b>Runoff duration</b>       | Elapsed time between the beginning and end of a runoff event.   |
| <b>Saline-sodic soil</b>     | Soil containing sufficient exchangeable sodium to interfere with the growth of most crops and containing appreciable quantities of soluble salts. The exchangeable sodium percentage is greater than 15, the electrical conductivity of the saturation extract is greater than 4 mS/cm (0.01 mho/in), and the exchangeable sodium percentage is less than 15. |
| <b>Saltation</b>             | Soil movement by water or wind where particles skip or bounce along the streambed or soil surface.  |
| <b>Sand</b>                  | Soil particles ranging from 50 to 200 $\mu\text{m}$ in diameter. Soil material containing 85 percent or more particles in this size range.  |
| <b>Sand lens</b>             | Lenticular band of sand in distinctly sedimentary banded material.  |
| <b>Saturated flow</b>        | Flow of water through a porous material under saturated conditions.   |
| <b>Saturation point</b>      | The water content at which a soil or aquifer will no longer absorb any water without losing an equal amount.  |
| <b>Seepage</b>               | The movement of water into and through the soil from unlined canals, ditches, and water storage facilities.   |
| <b>Semiarid climate</b>      | Climate characterized as neither entirely arid nor humid, but intermediate between the two conditions. A region is usually considered as semiarid when precipitation averages between 250 mm (10 in) and 500 mm (20 in) per year.   |
| <b>Side inlet (drainage)</b> | A facility to safely convey surface water into a lateral or main drain.   |
| <b>Side slopes</b>           | Slope of the sides of a channel or embankment, horizontal to vertical distance (written 2:1).   |
| <b>Silt</b>                  | (1) A soil separate consisting of particles between 2 and 50 $\mu\text{m}$ in diameter.<br>(2) (colloquial) Deposits of sediment that may contain soil particles of all sizes.  |
| <b>Silt bar</b>              | A deposition of sediment in a channel.  |
| <b>Sink</b>                  | A relatively small surface depression that allows surface drainage to enter the subsurface soil water system.   |
| <b>Siphon drain</b>          | Sealed drain where atmospheric pressure forces water over an intervening elevation into an outlet at a level lower than the inlet.  |
| <b>Sodic soil</b>            | A nonsaline soil containing sufficient exchangeable sodium to adversely affect crop production and soil structure. The exchangeable sodium percentage is greater than 15 and the electrical conductivity of the saturation extract is less than 4 mS/cm (0.01).   |

---

|  |   |
|--|---|
| <b>Sodium adsorption ratio (SAR)</b>   | The proportion of soluble sodium ions in relation to the soluble calcium and magnesium ions in the soil water extract (can be used to predict the exchangeable sodium percentage).  |
| <b>Sodium percentage</b>               | Percentage of total cations that is sodium in water or soil solution.   |
| <b>Soil</b>                            | The unconsolidated minerals and material on the immediate surface of the Earth that serves as a natural medium for the growth of plants.  |
| <b>Soil aeration</b>                   | Process by which air and other gases enter the soil or are exchanged.   |
| <b>Soil compaction</b>                 | Consolidation, reduction in porosity, and collapse of the structure of soil when subjected to surface loads.  |
| <b>Soil conservation</b>               | Protection of soil against physical loss by erosion and chemical deterioration by the application of management and land use methods that safeguard the soil against all natural and human-induced factors.   |
| <b>Soil erodibility</b>                | A measure of the soil's susceptibility to erosional processes.  |
| <b>Soil erosion</b>                    | Detachment and movement of soil from the land surface by wind or water.   |
| <b>Soil horizon</b>                    | A layer of soil differing from adjacent genetically related layers in physical, chemical, and biological properties or characteristics.   |
| <b>Soil organic matter</b>             | Organic fraction of the soil, including plant and animal residue in various stages of decomposition, cells and tissues of soil organisms, and substances synthesized by the soil population.  |
| <b>Soil profile</b>                    | Vertical section of the soil from the surface through all its horizons into the parent material.  |
| <b>Soil series</b>                     | The lowest category of U.S. system of soil taxonomy. A conceptualized class of soil bodies having similar characteristics and arrangement in the soil profile.  |
| <b>Soil structure</b>                  | The combination or arrangement of primary soil particles, into secondary particles, units, or peds that make up the soil mass. These secondary units may be, but usually are not, arranged in the profile in such a manner as to give a distinctive characteristic pattern. The principal types of soil structure are platy, prismatic, columnar, blocky, and granular. |
| <b>Soil texture</b>                    | Classification of soil by the relative proportions of sand, silt, and clay present in the soil.   |
| <b>Soil water</b>                      | All forms of water in the soil.   |
| <b>Soil-water characteristic curve</b> | Soil-specific relationship between the soil-water matric potential and soil-water content.  |



---

|                             |   |
|-----------------------------|---|
| <b>Soil-water potential</b> | The amount of work that must be done per unit quantity of pure water to transport reversibly and isothermally an infinitesimal quantity of water from a pool of pure water at a specified elevation at atmospheric pressure to the soil water at the point under consideration. |
| <b>Specific retention</b>   | Amount of water that a unit volume of porous media or soil, after being saturated, will retain against the force of gravity (compare to specific yield).  |
| <b>Specific yield</b>       | Amount of water that a unit volume of porous media or soil, after being saturated, will yield when drained by gravity (compare to specific retention).  |
| <b>Spillway</b>             | Conduit through or around a dam or dike for the passage of excess water.  |
| <b>Spoilbank</b>            | Excavated soil piled along a canal, ditch, or basin.  |
| <b>Stabilized grade</b>     | Slope of a channel at which neither erosion nor deposition occurs.  |
| <b>Staff gage</b>           | Graduated scale, generally vertical, from which the water surface elevation may be read.  |
| <b>Stage</b>                | Elevation of a water surface above or below an established datum gauge height.  |
| <b>Start trench</b>         | The excavation performed at the beginning of the installation of a drain to establish grade and permit entry to install tubing, outlet pipe, or junctions (also known as <i>start hole</i> or <i>pilot hole</i> ).  |
| <b>Static head</b>          | The potential energy resulting from elevation differences (see Head).   |
| <b>Static lift</b>          | Vertical distance between source and discharge water levels in a pump installation.   |
| <b>Steady flow</b>          | Open channel flow in which the rate and cross-sectional area remain constant with time at a given station.  |
| <b>Storage coefficient</b>  | See Specific yield.   |
| <b>Stratified soils</b>     | Soils that are composed of layers usually varying in permeability and texture.  |
| <b>Stretch (drainage)</b>   | The percent increase in length of drain tubing caused by bending or tension forces during installation.   |
| <b>Subgrade</b>             | Earth material beneath a subsurface drain or foundation.  |
| <b>Subirrigation</b>        | Application of irrigation water below the ground surface by raising the water table to within or near the root zone.  |
| <b>Subsoiling</b>           | Tillage operation to loosen the soil below the tillage zone without inversion and with a minimum of mixing with the tilled zone.  |

---

|                                  |   |
|----------------------------------|---|
| <b>Subsurface drain</b>          | Subsurface conduits used primarily to remove subsurface water from soil. Classifications of subsurface drains include pipe drains, tile drains, and blind drains.   |
| <b>Subsurface drain storage</b>  | Volume of water that can be stored in the subsurface pipeline without reducing the effectiveness of the pipe or tile drain.   |
| <b>Subsurface water</b>          | Water beneath the ground or pavement surface. Sometimes referred to as ground water or soil water.  |
| <b>Suction lift</b>              | Vertical distance between the elevation of the surface of the water source and the center of the pump impeller.   |
| <b>Surface collecting drains</b> | Ditches used to remove pondages, and move water more rapidly into outlet drains.  |
| <b>Surface drainage</b>          | The diversion or orderly removal of excess water from the surface of land by means of improved natural or constructed channels, supplemented when necessary by shaping and grading of land surfaces to such channels. |
| <b>Surface inlet</b>             | Structure for diverting surface water into an open ditch, subsurface drain, or pipeline.  |
| <b>Surface runoff</b>            | Precipitation, snowmelt, or irrigation in excess of what can infiltrate and be stored in small surface depressions.   |
| <b>Surface sealing</b>           | Reorienting and packing of dispersed soil particles in the immediate surface layer of soil and clogging of surface pores resulting in reduced infiltration.   |
| <b>Surface soil</b>              | The uppermost part of the soil, ordinarily moved in tillage, or its equivalent in uncultivated soils, ranging in depth from 10 to 20 cm (4 to 8 in). Sometimes called <i>soil management zone</i> .                   |
| <b>Surface storage</b>           | Sum of detention and channel storage excluding depression storage. Represents at any given moment the total water enroute to an outlet from an area or watershed.   |
| <b>Surface water</b>             | Water flowing or stored on the Earth's surface.   |
| <b>Swelling (soil)</b>           | Physical expansion of the soil mass in an expanding type clay, usually caused by an increase in water content.  |
| <b>Three-edge bearing test</b>   | A test used to determine the strength of concrete pipe, stated in force per unit length.  |
| <b>Tidal gate</b>                | Gate that allows flow of drainage water seaward at low tide and prevents return flow at high tide. Sometimes called a <i>sea gate</i> .   |
| <b>Tile alignment</b>            | Degree to which the centerline of a tile falls in line with the centerline of adjacent tiles.   |

---

|                                   |  |
|-----------------------------------|--|
| <b>Tile cradle</b>                | Support laid underneath a tile line in unstable soil to keep horizontal and vertical alignment of the tile line.   |
| <b>Tile density</b>               | Quality of a tile that determines its crushing strength and its ability to resist water absorption and damage by freezing and thawing.   |
| <b>Tile drain</b>                 | Drain constructed by laying drain tile with unsealed joints in the bottom of a trench that is then refilled. Tile is generally constructed of clay or concrete.  |
| <b>Tile joint</b>                 | Opening between two drain tiles through which water from the surrounding soil flows (compare with crack width).  |
| <b>Tile probe</b>                 | A hand tool consisting of a rod with a tee handle on one end and an enlarged point on the other end. The tool is pushed or driven into the soil to locate pipe, tile, tubing, or a trench.   |
| <b>Top width</b>                  | Horizontal distance across the top of a ditch or embankment.   |
| <b>Torpedo</b>                    | Channel forming head of a mole plow (preferred term is bullet).  |
| <b>Total dynamic head</b>         | Head required to pump water from its source to the point of discharge; equal to the static lift plus head losses in pipes and fittings plus the increase in velocity head.   |
| <b>Total suction head</b>         | Head required to lift water from the water source to the centerline of the pump plus velocity head, entrance losses, and friction losses in suction pipeline.  |
| <b>Trailing plug</b>              | Plug following the mole plow torpedo, smoothing and strengthening the wall of the mole channel (see Mole drain or Bullet).   |
| <b>Transverse drainage system</b> | A drainage system usually at some angle to a roadway.  |
| <b>Trench box</b>                 | A box-like piece of equipment placed in a trench to prevent collapse of the sides of the trench and thereby provide safe working conditions.   |
| <b>Turbine pump</b>               | A type of pump having one or more stages, each consisting of an impeller on a vertical shaft, surrounded by stationary and usually symmetrical guide vanes. Combines the energy-imparting characteristics of axial-flow and propeller pumps. |
| <b>Twin ditch</b>                 | See W-ditch.   |
| <b>Unavailable soil water</b>     | That portion of water in a soil held so tightly by adhesion and other soil forces that it cannot be absorbed by plants rapidly enough to sustain growth. Soil water at permanent wilting point.  |
| <b>Unconfined aquifer</b>         | An aquifer whose upper boundary consists of relatively porous natural material that transmits water readily and does not confine water. The water level in the aquifer is the water table.   |

---

|                               |   |
|-------------------------------|---|
| <b>Underlayment</b>           | Something laid underneath a drain pipe, such as gravel or stone bedding material.   |
| <b>Unsaturated flow</b>       | Movement of water in soil in which the pores are not completely filled with water.  |
| <b>Unsaturated zone</b>       | That part of the soil profile in which the voids are not completely filled with water.  |
| <b>USBR</b>                   | United States Bureau of Reclamation, U.S. Department of the Interior.   |
| <b>USCS</b>                   | Unified Soil Classification System.   |
| <b>Vadose zone</b>            | Zone of unsaturated soil that extends from the soil surface to the ground water table.  |
| <b>Velocity head</b>          | Head or energy resulting from the velocity of a moving fluid; equal to the square of the mean velocity divided by twice the gravitational acceleration.   |
| <b>Vent</b>                   | An appurtenance to a pipeline that permits the passage of air to or from the pipeline.  |
| <b>Vertical drain</b>         | Vertical shaft to a permeable substratum into which surface and subsurface drainage water is channeled.   |
| <b>W-ditch</b>                | Two closely spaced, parallel, single channels having the spoil from construction placed between them. To permit unimpeded runoff into them from surrounding lands. Sometimes called a W-drain.                            |
| <b>Water table</b>            | The upper limit of a free water surface in a saturated soil or underlying material.   |
| <b>Water table management</b> | The control of ground water levels by regulating the flow of water in the controlled drainage and subirrigation modes.  |
| <b>Weir</b>                   | (1) Structure across a stream to control or divert the flow. (2) Device for measuring the flow of water. Classification includes sharpcrested or broadcrested with rectangular, trapezoidal, or triangular cross section. |
| <b>Weir head</b>              | Vertical distance from the crest of a weir to the water surface in the forebay above the weir, not including the velocity head of approach.   |
| <b>Weir pond or box</b>       | Pond upstream from a weir generally used to reduce the velocity of approach and allow for full contraction of flow for measurement purposes. Also acts as a trap.   |
| <b>Well casing</b>            | Pipe installed within a borehole to prevent collapse of sidewall material, to receive and protect pump and pump column, and to allow waterflow from the aquifer to pump intake.   |

- Well development** The process of removing fine formation materials or materials introduced during well construction from the well intake zone for the purpose of stabilizing and increasing the permeability of the well intake zone and the filter pack material.
- Well efficiency** Ratio of theoretical drawdown to measured drawdown. Theoretical drawdown is estimated from adjacent observation well data obtained during well test.
- Wetted perimeter** Length of the wetted contact between a conveyed liquid and the open channel or closed conduit conveying it, measured in a plane at right angles to the direction of flow.
- Wheel trencher** An excavator that uses a rigid round wheel with attached buckets and cutters to carry spoil out of the trench. It may include a conveyor or slide to deposit spoil to one or both sides of the trench.



---

# Appendixes

---

|                     |   |               |
|---------------------|---|---------------|
| <b>Appendix 14A</b> | <b>Ditch design tables</b>                                      | <b>14-143</b> |
| <b>Appendix 14B</b> | <b>Tables for computing culvert discharge</b>                   | <b>14-153</b> |
| <b>Appendix 14C</b> | <b>Salinity monitoring equipment</b>                            | <b>14-157</b> |
| <b>Appendix 14D</b> | <b>Auger hole method for determining hydraulic conductivity</b> | <b>14-161</b> |
| <b>Appendix 14E</b> | <b>Transient flow method</b>                                    | <b>14-171</b> |
| <b>Appendix 14F</b> | <b>Drainage around home sites</b>                               | <b>14-187</b> |





# Appendix 14A

# Ditch Design Tables

**Appendix 14A** Ditch design tables (sheet 1 of 10) using  $Q=VA$  with Manning's equation

$$V = \frac{Q}{A}$$

where:

V = avg. flow velocity (ft/s)

Q = flow rate (ft<sup>3</sup>/s)

A = square foot of pipe cross section

Values of "V" and "Q" for trapezoidal ditches with 4-foot bottom, side slopes 2:1, n = .045

| Depth (ft)                     | 2.0   |      | 2.1   |      | 2.2   |      | 2.3   |      | 2.4   |      | 2.5  |      | 2.6   |      |
|--------------------------------|-------|------|-------|------|-------|------|-------|------|-------|------|------|------|-------|------|
| X-sec. area (ft <sup>2</sup> ) | 16.00 |      | 17.22 |      | 18.48 |      | 19.78 |      | 21.12 |      | 22.5 |      | 23.92 |      |
| Hyd. radius (ft)               | 1.24  |      | 1.29  |      | 1.34  |      | 1.38  |      | 1.43  |      | 1.48 |      | 1.53  |      |
| S (ft/ft)                      | V     | Q    | V     | Q    | V     | Q    | V     | Q    | V     | Q    | V    | Q    | V     | Q    |
| .00005                         | .27   | 4.3  | .28   | 4.8  | .28   | 5.2  | .29   | 5.7  | .30   | 6.3  | .30  | 6.8  | .31   | 7.4  |
| .00010                         | .38   | 6.1  | .39   | 6.7  | .40   | 7.4  | .41   | 8.1  | .42   | 8.9  | .43  | 9.7  | .44   | 10.5 |
| .00015                         | .47   | 7.5  | .48   | 8.2  | .49   | 9.1  | .50   | 9.9  | .51   | 10.9 | .53  | 11.8 | .54   | 12.9 |
| .00020                         | .54   | 8.6  | .55   | 9.5  | .57   | 10.5 | .58   | 11.5 | .59   | 12.5 | .61  | 13.7 | .62   | 14.8 |
| .00025                         | .60   | 9.6  | .62   | 10.6 | .63   | 11.7 | .65   | 12.8 | .66   | 14.0 | .68  | 15.3 | .69   | 16.6 |
| .00030                         | .66   | 10.5 | .68   | 11.6 | .69   | 12.8 | .71   | 14.0 | .73   | 15.3 | .74  | 16.7 | .76   | 18.2 |
| .00035                         | .71   | 11.4 | .73   | 12.6 | .75   | 13.8 | .77   | 15.2 | .79   | 16.6 | .80  | 18.1 | .82   | 19.6 |
| .00040                         | .76   | 12.2 | .78   | 13.4 | .80   | 14.8 | .82   | 16.2 | .84   | 17.7 | .86  | 19.3 | .88   | 21.0 |
| .00045                         | .81   | 12.9 | .83   | 14.3 | .84   | 15.5 | .87   | 17.2 | .89   | 18.8 | .91  | 20.5 | .93   | 22.3 |
| .00050                         | .85   | 13.6 | .87   | 15.0 | .89   | 16.5 | .92   | 18.1 | .94   | 19.8 | .96  | 21.6 | .98   | 23.4 |
| .00055                         | .89   | 14.3 | .92   | 15.8 | .93   | 17.2 | .96   | 19.0 | .98   | 20.8 | 1.01 | 22.6 | 1.03  | 24.6 |
| .00060                         | .93   | 14.9 | .96   | 16.5 | .98   | 18.1 | 1.00  | 19.8 | 1.03  | 21.7 | 1.05 | 23.7 | 1.07  | 25.7 |
| .00065                         | .97   | 15.5 | 1.00  | 17.1 | 1.02  | 18.9 | 1.04  | 20.7 | 1.07  | 22.6 | 1.09 | 24.6 | 1.12  | 26.7 |
| .00070                         | 1.01  | 16.1 | 1.03  | 17.8 | 1.06  | 19.6 | 1.08  | 21.4 | 1.11  | 23.4 | 1.14 | 25.5 | 1.16  | 27.8 |
| .00075                         | 1.04  | 16.7 | 1.07  | 18.4 | 1.10  | 20.3 | 1.12  | 22.2 | 1.15  | 24.3 | 1.18 | 26.4 | 1.20  | 28.7 |
| .00080                         | 1.08  | 17.2 | 1.10  | 19.0 | 1.13  | 20.9 | 1.16  | 22.9 | 1.19  | 25.1 | 1.21 | 27.3 | 1.24  | 29.6 |
| .00085                         | 1.11  | 17.7 | 1.14  | 19.6 | 1.17  | 21.6 | 1.19  | 23.6 | 1.22  | 25.8 | 1.25 | 28.2 | 1.28  | 30.6 |
| .00090                         | 1.14  | 18.2 | 1.17  | 20.2 | 1.20  | 22.2 | 1.23  | 24.3 | 1.26  | 26.6 | 1.29 | 29.0 | 1.32  | 31.5 |
| .00095                         | 1.17  | 18.8 | 1.20  | 20.7 | 1.23  | 22.8 | 1.26  | 25.0 | 1.29  | 27.3 | 1.32 | 29.7 | 1.35  | 32.3 |
| .00100                         | 1.20  | 19.2 | 1.23  | 21.3 | 1.27  | 23.4 | 1.30  | 25.6 | 1.33  | 28.0 | 1.36 | 30.5 | 1.39  | 33.2 |
| .0011                          | 1.26  | 20.2 | 1.30  | 22.3 | 1.33  | 24.5 | 1.36  | 26.9 | 1.39  | 29.4 | 1.42 | 32.0 | 1.45  | 34.8 |
| .0012                          | 1.32  | 21.1 | 1.35  | 23.3 | 1.39  | 25.6 | 1.42  | 28.1 | 1.45  | 30.7 | 1.49 | 33.4 | 1.52  | 36.3 |
| .0013                          | 1.37  | 21.9 | 1.41  | 24.2 | 1.44  | 26.7 | 1.48  | 29.2 | 1.51  | 32.0 | 1.55 | 34.8 | 1.58  | 37.8 |
| .0014                          | 1.42  | 22.8 | 1.46  | 25.2 | 1.50  | 27.7 | 1.53  | 30.3 | 1.57  | 33.2 | 1.61 | 36.1 | 1.64  | 39.2 |
| .0015                          | 1.47  | 23.6 | 1.51  | 26.0 | 1.55  | 28.6 | 1.59  | 31.4 | 1.62  | 34.3 | 1.66 | 37.4 | 1.70  | 40.6 |
| .0016                          | 1.52  | 24.3 | 1.56  | 26.9 | 1.60  | 29.6 | 1.64  | 32.4 | 1.68  | 35.4 | 1.72 | 38.6 | 1.75  | 41.9 |
| .0017                          | 1.57  | 25.1 | 1.61  | 27.7 | 1.65  | 30.5 | 1.69  | 33.4 | 1.73  | 36.5 | 1.77 | 39.8 | 1.81  | 43.2 |
| .0018                          | 1.61  | 25.8 | 1.66  | 28.5 | 1.70  | 31.4 | 1.74  | 34.4 | 1.78  | 37.6 | 1.82 | 41.0 | 1.86  | 44.5 |
| .0019                          | 1.66  | 26.5 | 1.70  | 29.3 | 1.74  | 32.2 | 1.79  | 35.3 | 1.83  | 38.6 | 1.87 | 42.1 | 1.91  | 45.7 |
| .0020                          | 1.70  | 27.2 | 1.75  | 30.1 | 1.78  | 32.9 | 1.83  | 36.2 | 1.88  | 39.6 | 1.92 | 43.2 | 1.96  | 46.9 |

**Appendix 14A** Ditch design tables (sheet 2 of 10) using  $Q=VA$  with Manning's equation—continued

$$V = \frac{Q}{A}$$

where:  
 V = avg. flow velocity (fps)  
 Q = flow rate (ft<sup>3</sup>)  
 A = square foot of pipe cross section

Values of "V" and "Q" for trapezoidal ditches with 4-foot bottom, side slopes 2:1, n = .045

| Depth (ft)                     | 2.7   |      | 2.8   |      | 3.0   |      | 3.2   |      | 3.4   |      | 3.6   |      | 3.8   |       |
|--------------------------------|-------|------|-------|------|-------|------|-------|------|-------|------|-------|------|-------|-------|
| X-sec. area (ft <sup>2</sup> ) | 25.38 |      | 26.88 |      | 30.00 |      | 33.28 |      | 36.72 |      | 40.32 |      | 44.08 |       |
| Hyd. radius (ft)               | 1.58  |      | 1.63  |      | 1.72  |      | 1.82  |      | 1.91  |      | 2.01  |      | 2.10  |       |
| S (ft/ft)                      | V     | Q    | V     | Q    | V     | Q    | V     | Q    | V     | Q    | V     | Q    | V     | Q     |
| .00005                         | .32   | 8.0  | .32   | 8.7  | .34   | 10.1 | .35   | 11.6 | .36   | 13.2 | .37   | 15.0 | .38   | 16.8  |
| .00010                         | .45   | 11.4 | .46   | 12.3 | .47   | 14.2 | .49   | 16.4 | .51   | 18.6 | .53   | 21.2 | .54   | 23.8  |
| .00015                         | .55   | 13.9 | .56   | 15.1 | .58   | 17.4 | .60   | 20.1 | .62   | 22.8 | .64   | 26.0 | .66   | 29.2  |
| .00020                         | .63   | 16.1 | .65   | 17.4 | .67   | 20.1 | .70   | 23.2 | .72   | 26.4 | .74   | 30.0 | .77   | 33.7  |
| .00025                         | .71   | 17.9 | .72   | 19.4 | .75   | 22.5 | .78   | 25.9 | .80   | 29.5 | .83   | 33.5 | .86   | 37.7  |
| .00030                         | .78   | 19.7 | .79   | 21.3 | .82   | 24.6 | .85   | 28.4 | .88   | 32.3 | .91   | 36.7 | .94   | 41.3  |
| .00035                         | .84   | 21.2 | .86   | 23.0 | .89   | 26.6 | .92   | 30.7 | .95   | 34.9 | .98   | 39.7 | 1.01  | 44.6  |
| .00040                         | .90   | 22.7 | .91   | 24.6 | .95   | 28.4 | .98   | 32.8 | 1.02  | 37.3 | 1.05  | 42.4 | 1.08  | 47.7  |
| .00045                         | .95   | 24.1 | .97   | 26.1 | 1.01  | 30.2 | 1.04  | 34.7 | 1.08  | 39.6 | 1.12  | 45.0 | 1.15  | 50.6  |
| .00050                         | 1.00  | 25.4 | 1.02  | 27.5 | 1.06  | 31.8 | 1.10  | 36.6 | 1.14  | 41.7 | 1.18  | 47.4 | 1.21  | 53.3  |
| .00055                         | 1.05  | 26.7 | 1.07  | 28.8 | 1.11  | 33.3 | 1.15  | 38.4 | 1.19  | 43.7 | 1.23  | 49.7 | 1.27  | 55.9  |
| .00060                         | 1.10  | 27.8 | 1.12  | 30.1 | 1.16  | 34.8 | 1.21  | 40.1 | 1.24  | 45.7 | 1.29  | 51.9 | 1.33  | 58.4  |
| .00065                         | 1.15  | 29.0 | 1.17  | 31.3 | 1.21  | 36.2 | 1.26  | 41.8 | 1.30  | 47.6 | 1.34  | 54.1 | 1.38  | 60.8  |
| .00070                         | 1.18  | 30.1 | 1.21  | 32.5 | 1.25  | 37.6 | 1.30  | 43.3 | 1.34  | 49.3 | 1.39  | 56.1 | 1.43  | 63.1  |
| .00075                         | 1.23  | 31.0 | 1.25  | 33.7 | 1.30  | 38.9 | 1.35  | 44.9 | 1.39  | 51.1 | 1.44  | 58.1 | 1.48  | 65.3  |
| .00080                         | 1.27  | 32.1 | 1.29  | 34.8 | 1.34  | 40.2 | 1.39  | 46.3 | 1.44  | 52.7 | 1.49  | 60.0 | 1.53  | 67.4  |
| .00085                         | 1.31  | 33.1 | 1.33  | 35.8 | 1.38  | 41.4 | 1.43  | 47.7 | 1.48  | 54.4 | 1.53  | 61.8 | 1.58  | 69.5  |
| .00090                         | 1.34  | 34.1 | 1.37  | 36.9 | 1.42  | 42.7 | 1.48  | 49.1 | 1.52  | 56.0 | 1.58  | 63.7 | 1.62  | 71.5  |
| .00095                         | 1.38  | 35.0 | 1.41  | 37.9 | 1.46  | 43.8 | 1.52  | 50.5 | 1.57  | 57.5 | 1.62  | 65.3 | 1.67  | 73.5  |
| .00100                         | 1.42  | 35.9 | 1.45  | 38.8 | 1.5   | 44.9 | 1.56  | 51.8 | 1.61  | 59.0 | 1.66  | 67.0 | 1.71  | 75.4  |
| .0011                          | 1.49  | 37.7 | 1.52  | 40.8 | 1.57  | 47.2 | 1.63  | 54.3 | 1.69  | 61.9 | 1.77  | 71.5 | 1.79  | 79.1  |
| .0012                          | 1.55  | 39.3 | 1.58  | 42.6 | 1.64  | 49.3 | 1.70  | 56.7 | 1.76  | 64.6 | 1.82  | 73.4 | 1.87  | 82.6  |
| .0013                          | 1.61  | 41.0 | 1.65  | 44.3 | 1.71  | 51.3 | 1.77  | 59.0 | 1.83  | 67.3 | 1.90  | 76.5 | 1.95  | 86.0  |
| .0014                          | 1.68  | 42.3 | 1.71  | 46.0 | 1.77  | 53.2 | 1.84  | 61.3 | 1.90  | 69.8 | 1.97  | 79.3 | 2.02  | 89.2  |
| .0015                          | 1.73  | 43.8 | 1.77  | 47.6 | 1.84  | 55.1 | 1.91  | 63.8 | 1.97  | 72.2 | 2.04  | 82.1 | 2.10  | 92.4  |
| .0016                          | 1.79  | 45.4 | 1.83  | 49.1 | 1.90  | 56.9 | 1.97  | 65.5 | 2.03  | 74.6 | 2.10  | 84.8 | 2.16  | 95.4  |
| .0017                          | 1.85  | 46.8 | 1.88  | 50.6 | 1.95  | 58.6 | 2.03  | 67.5 | 2.09  | 76.9 | 2.17  | 87.4 | 2.23  | 98.3  |
| .0018                          | 1.90  | 48.2 | 1.94  | 52.1 | 2.01  | 60.3 | 2.09  | 69.5 | 2.16  | 79.1 | 2.23  | 90.0 | 2.30  | 101.2 |
| .0019                          | 1.95  | 49.5 | 1.99  | 53.5 | 2.07  | 62.0 | 2.15  | 71.4 | 2.21  | 81.3 | 2.29  | 92.4 | 2.36  | 103.9 |
| .0020                          | 2.00  | 50.8 | 2.04  | 54.9 | 2.12  | 63.6 | 2.20  | 73.2 | 2.27  | 83.4 | 2.35  | 94.8 | 2.42  | 106.6 |

**Appendix 14A** Ditch design tables (sheet 3 of 10) using  $Q=VA$  with Manning's equation—continued  $V = \frac{Q}{A}$ Values of "V" and "Q" for trapezoidal ditches with 4-foot bottom, side slopes 2:1,  $n = .045$ 

where:

V = avg. flow velocity (ft/s)

Q = flow rate (ft<sup>3</sup>/s)

A = square foot of pipe cross section

| Depth (ft)                     | 4.0   |       | 4.2   |       | 4.4   |       | 4.6   |       | 4.8   |       | 5.0   |       | 5.2   |       |
|--------------------------------|-------|-------|-------|-------|-------|-------|-------|-------|-------|-------|-------|-------|-------|-------|
| X-sec. area (ft <sup>2</sup> ) | 48.00 |       | 52.08 |       | 56.32 |       | 60.72 |       | 65.28 |       | 70.00 |       | 74.88 |       |
| Hyd. radius (ft)               | 2.19  |       | 2.29  |       | 2.38  |       | 2.47  |       | 2.56  |       | 2.66  |       | 2.75  |       |
| S (ft/ft)                      | V     | Q     | V     | Q     | V     | Q     | V     | Q     | V     | Q     | V     | Q     | V     | Q     |
| .00005                         | .39   | 18.2  | .41   | 21.1  | .42   | 23.4  | .43   | 25.9  | .44   | 28.5  | .45   | 31.4  | .46   | 41.0  |
| .00010                         | .56   | 26.7  | .57   | 29.8  | .59   | 33.1  | .60   | 36.6  | .62   | 40.3  | .63   | 44.4  | .65   | 48.5  |
| .00015                         | .68   | 32.7  | .70   | 36.6  | .72   | 40.6  | .74   | 44.9  | .76   | 49.4  | .78   | 54.3  | .79   | 59.5  |
| .00020                         | .78   | 37.3  | .81   | 42.2  | .83   | 46.9  | .85   | 51.8  | .87   | 57.0  | .90   | 62.7  | .92   | 68.6  |
| .00025                         | .88   | 42.2  | .91   | 47.2  | .93   | 52.4  | .95   | 57.9  | .98   | 63.7  | 1.00  | 70.1  | 1.02  | 76.7  |
| .00030                         | .96   | 46.3  | .99   | 51.7  | 1.02  | 57.4  | 1.04  | 63.4  | 1.07  | 69.8  | 1.10  | 76.8  | 1.12  | 84.0  |
| .00035                         | 1.04  | 50.0  | 1.07  | 55.8  | 1.10  | 62.0  | 1.13  | 68.5  | 1.16  | 75.4  | 1.19  | 83.0  | 1.21  | 90.8  |
| .00040                         | 1.11  | 53.4  | 1.15  | 59.7  | 1.18  | 66.2  | 1.21  | 73.2  | 1.24  | 80.6  | 1.27  | 88.7  | 1.30  | 97.0  |
| .00045                         | 1.18  | 56.6  | 1.22  | 63.3  | 1.25  | 70.2  | 1.28  | 77.7  | 1.31  | 85.5  | 1.34  | 94.1  | 1.37  | 102.9 |
| .00050                         | 1.24  | 59.7  | 1.28  | 66.8  | 1.32  | 74.1  | 1.35  | 81.9  | 1.38  | 90.2  | 1.42  | 99.2  | 1.45  | 108.4 |
| .00055                         | 1.31  | 62.6  | 1.34  | 70.0  | 1.38  | 77.7  | 1.41  | 85.9  | 1.45  | 94.5  | 1.49  | 104.0 | 1.52  | 113.7 |
| .00060                         | 1.36  | 65.4  | 1.40  | 73.1  | 1.44  | 81.1  | 1.48  | 89.7  | 1.51  | 98.7  | 1.55  | 108.6 | 1.59  | 118.8 |
| .00065                         | 1.42  | 68.1  | 1.46  | 76.1  | 1.50  | 84.5  | 1.54  | 93.3  | 1.57  | 102.8 | 1.62  | 113.1 | 1.65  | 123.7 |
| .00070                         | 1.47  | 70.7  | 1.52  | 79.0  | 1.56  | 87.6  | 1.60  | 96.9  | 1.63  | 106.7 | 1.68  | 117.4 | 1.71  | 128.3 |
| .00075                         | 1.52  | 73.2  | 1.57  | 81.8  | 1.61  | 90.7  | 1.65  | 100.3 | 1.69  | 110.4 | 1.74  | 121.5 | 1.77  | 132.8 |
| .00080                         | 1.57  | 75.5  | 1.62  | 84.4  | 1.66  | 93.7  | 1.71  | 103.5 | 1.75  | 114.0 | 1.79  | 125.4 | 1.83  | 137.2 |
| .00085                         | 1.62  | 77.9  | 1.67  | 87.0  | 1.71  | 96.5  | 1.76  | 106.7 | 1.80  | 117.6 | 1.85  | 129.3 | 1.89  | 141.4 |
| .00090                         | 1.67  | 80.1  | 1.72  | 89.6  | 1.76  | 99.4  | 1.81  | 109.8 | 1.85  | 120.9 | 1.90  | 133.1 | 1.94  | 145.5 |
| .00095                         | 1.72  | 82.3  | 1.77  | 92.0  | 1.81  | 102.1 | 1.86  | 112.8 | 1.90  | 124.2 | 1.95  | 136.7 | 2.00  | 149.5 |
| .00100                         | 1.76  | 84.3  | 1.81  | 94.4  | 1.86  | 104.7 | 1.91  | 115.7 | 1.95  | 127.4 | 2.00  | 140.2 | 2.05  | 153.4 |
| .0011                          | 1.85  | 88.6  | 1.90  | 99.0  | 1.95  | 109.9 | 2.00  | 121.4 | 2.05  | 133.7 | 2.10  | 147.1 | 2.15  | 160.9 |
| .0012                          | 1.93  | 92.5  | 1.99  | 103.4 | 2.04  | 114.7 | 2.09  | 126.8 | 2.14  | 139.6 | 2.20  | 153.7 | 2.24  | 167.7 |
| .0013                          | 2.01  | 96.3  | 2.07  | 107.7 | 2.12  | 119.5 | 2.17  | 132.0 | 2.23  | 145.3 | 2.29  | 160.0 | 2.34  | 174.9 |
| .0014                          | 2.08  | 99.9  | 2.15  | 111.7 | 2.20  | 124.0 | 2.26  | 137.0 | 2.31  | 150.8 | 2.37  | 166.0 | 2.42  | 181.5 |
| .0015                          | 2.16  | 103.4 | 2.22  | 115.6 | 2.28  | 128.3 | 2.34  | 141.8 | 2.39  | 156.1 | 2.45  | 171.8 | 2.51  | 187.9 |
| .0016                          | 2.23  | 106.9 | 2.29  | 119.4 | 2.35  | 132.5 | 2.41  | 146.5 | 2.47  | 161.2 | 2.53  | 177.4 | 2.59  | 194.0 |
| .0017                          | 2.29  | 110.1 | 2.36  | 123.1 | 2.43  | 136.6 | 2.49  | 151.0 | 2.55  | 166.2 | 2.61  | 182.8 | 2.67  | 200.0 |
| .0018                          | 2.36  | 113.3 | 2.43  | 126.7 | 2.50  | 140.5 | 2.56  | 155.3 | 2.62  | 171.0 | 2.69  | 188.2 | 2.75  | 205.8 |
| .0019                          | 2.43  | 116.4 | 2.50  | 130.2 | 2.56  | 144.4 | 2.63  | 159.6 | 2.69  | 175.7 | 2.76  | 193.3 | 2.82  | 211.5 |
| .0020                          | 2.49  | 119.4 | 2.56  | 133.5 | 2.63  | 148.1 | 2.70  | 163.7 | 2.76  | 180.2 | 2.83  | 198.3 | 2.90  | 216.9 |

**Appendix 14A** Ditch design tables (sheet 4 of 10) using  $Q=VA$  with Manning's equation—continued

$$V = \frac{Q}{A}$$

Values of "V" and "Q" for trapezoidal ditches with 4-foot bottom, side slopes 2:1,  $n = .040$

where:  
V = avg. flow velocity (ft/s)  
Q = flow rate (ft<sup>3</sup>/s)  
A = square foot of pipe cross section

| Depth (ft)                     | 5.4   |       | 5.6   |       | 5.8   |       | 6.0   |       | 6.2    |       | 6.4    |       | 6.6    |       |
|--------------------------------|-------|-------|-------|-------|-------|-------|-------|-------|--------|-------|--------|-------|--------|-------|
| X-sec. area (ft <sup>2</sup> ) | 79.92 |       | 85.12 |       | 90.48 |       | 96.00 |       | 101.68 |       | 107.52 |       | 113.52 |       |
| Hyd. radius (ft)               | 2.84  |       | 2.93  |       | 3.02  |       | 3.11  |       | 3.20   |       | 3.30   |       | 3.39   |       |
| S (ft/ft)                      | V     | Q     | V     | Q     | V     | Q     | V     | Q     | V      | Q     | V      | Q     | V      | Q     |
| .00005                         | .53   | 42.4  | .54   | 46.0  | .55   | 49.8  | .56   | 53.8  | .57    | 58.0  | .58    | 62.4  | .59    | 67.0  |
| .00010                         | .75   | 59.9  | .76   | 64.7  | .78   | 70.6  | .79   | 75.8  | .81    | 82.4  | .82    | 88.2  | .84    | 95.4  |
| .00015                         | .91   | 72.7  | .93   | 79.2  | .95   | 86.0  | .97   | 93.1  | .99    | 100.7 | 1.01   | 108.6 | 1.03   | 116.9 |
| .00020                         | 1.05  | 83.9  | 1.08  | 91.9  | 1.10  | 99.5  | 1.12  | 107.5 | 1.14   | 115.9 | 1.16   | 124.7 | 1.19   | 135.1 |
| .00025                         | 1.18  | 94.3  | 1.20  | 102.1 | 1.23  | 111.3 | 1.25  | 120.0 | 1.28   | 130.2 | 1.30   | 139.8 | 1.33   | 151.0 |
| .00030                         | 1.29  | 103.1 | 1.32  | 112.4 | 1.34  | 121.2 | 1.37  | 131.5 | 1.40   | 142.4 | 1.43   | 153.8 | 1.45   | 164.6 |
| .00035                         | 1.39  | 111.1 | 1.42  | 120.9 | 1.45  | 131.2 | 1.48  | 142.1 | 1.51   | 153.5 | 1.54   | 165.6 | 1.57   | 178.2 |
| .00040                         | 1.49  | 119.1 | 1.52  | 129.4 | 1.55  | 140.2 | 1.58  | 151.7 | 1.61   | 163.7 | 1.65   | 177.4 | 1.68   | 190.7 |
| .00045                         | 1.58  | 126.3 | 1.61  | 137.0 | 1.65  | 149.3 | 1.68  | 161.3 | 1.71   | 173.9 | 1.75   | 188.2 | 1.78   | 202.1 |
| .00050                         | 1.67  | 133.5 | 1.70  | 144.7 | 1.74  | 157.4 | 1.77  | 169.9 | 1.80   | 183.0 | 1.84   | 197.8 | 1.87   | 212.3 |
| .00055                         | 1.75  | 139.9 | 1.78  | 151.5 | 1.82  | 164.7 | 1.86  | 178.6 | 1.89   | 192.2 | 1.93   | 207.5 | 1.97   | 223.6 |
| .00060                         | 1.82  | 145.5 | 1.86  | 158.3 | 1.90  | 171.9 | 1.94  | 186.2 | 1.98   | 201.3 | 2.02   | 217.2 | 2.05   | 232.7 |
| .00065                         | 1.90  | 151.8 | 1.94  | 165.1 | 1.98  | 179.2 | 2.02  | 193.9 | 2.06   | 209.5 | 2.10   | 225.8 | 2.14   | 242.9 |
| .00070                         | 1.97  | 157.4 | 2.01  | 171.1 | 2.05  | 185.5 | 2.09  | 200.6 | 2.14   | 217.6 | 2.18   | 234.4 | 2.22   | 252.0 |
| .00075                         | 2.04  | 163.0 | 2.08  | 177.0 | 2.12  | 191.8 | 2.17  | 208.3 | 2.21   | 224.7 | 2.26   | 243.0 | 2.30   | 261.1 |
| .00080                         | 2.11  | 168.6 | 2.15  | 183.0 | 2.19  | 198.2 | 2.24  | 215.0 | 2.28   | 231.8 | 2.33   | 250.5 | 2.37   | 269.0 |
| .00085                         | 2.17  | 173.4 | 2.21  | 188.1 | 2.26  | 204.5 | 2.31  | 221.8 | 2.35   | 238.9 | 2.40   | 258.0 | 2.44   | 277.0 |
| .00090                         | 2.23  | 178.2 | 2.28  | 194.1 | 2.33  | 210.1 | 2.37  | 227.5 | 2.42   | 246.1 | 2.47   | 265.6 | 2.51   | 284.9 |
| .00095                         | 2.30  | 183.8 | 2.34  | 199.2 | 2.39  | 216.2 | 2.44  | 234.2 | 2.49   | 253.2 | 2.54   | 273.1 | 2.58   | 292.9 |
| .00100                         | 2.36  | 188.6 | 2.41  | 205.1 | 2.45  | 221.7 | 2.50  | 240.0 | 2.55   | 259.3 | 2.60   | 279.6 | 2.65   | 300.1 |
| .0011                          | 2.47  | 197.4 | 2.52  | 214.5 | 2.57  | 232.5 | 2.63  | 252.5 | 2.68   | 272.5 | 2.73   | 293.5 | 2.78   | 315.6 |
| .0012                          | 2.58  | 206.2 | 2.63  | 223.9 | 2.69  | 243.4 | 2.74  | 263.0 | 2.80   | 284.7 | 2.85   | 306.4 | 2.90   | 329.2 |
| .0013                          | 2.69  | 215.0 | 2.74  | 233.2 | 2.80  | 253.3 | 2.85  | 273.6 | 2.91   | 295.9 | 2.97   | 319.3 | 3.02   | 342.8 |
| .0014                          | 2.79  | 223.0 | 2.85  | 242.6 | 2.90  | 262.4 | 2.96  | 284.2 | 3.02   | 307.1 | 3.08   | 331.2 | 3.14   | 356.5 |
| .0015                          | 2.89  | 231.0 | 2.95  | 251.1 | 3.00  | 271.4 | 3.07  | 294.7 | 3.13   | 318.3 | 3.19   | 343.0 | 3.25   | 368.9 |
| .0016                          | 2.98  | 238.2 | 3.04  | 258.8 | 3.10  | 280.5 | 3.17  | 304.3 | 3.23   | 328.4 | 3.29   | 353.7 | 3.35   | 380.3 |
| .0017                          | 3.07  | 245.4 | 3.14  | 267.3 | 3.20  | 289.5 | 3.26  | 313.0 | 3.33   | 338.6 | 3.39   | 364.5 | 3.46   | 392.8 |
| .0018                          | 3.16  | 252.5 | 3.23  | 274.9 | 3.29  | 297.7 | 3.36  | 322.6 | 3.42   | 347.7 | 3.49   | 375.2 | 3.56   | 404.1 |
| .0019                          | 3.25  | 259.7 | 3.32  | 282.6 | 3.38  | 305.8 | 3.45  | 331.2 | 3.52   | 357.9 | 3.59   | 386.0 | 3.66   | 415.5 |
| .0020                          | 3.33  | 266.1 | 3.40  | 289.4 | 3.47  | 314.0 | 3.54  | 339.8 | 3.61   | 367.1 | 3.68   | 395.7 | 3.75   | 425.7 |

**Appendix 14A** Ditch design tables (sheet 5 of 10) using  $Q=VA$  with Manning's equation—continued

$$V = \frac{Q}{A}$$

Values of "V" and "Q" trapezoidal ditches with 6-foot bottom, side slopes 2:1,  $n = .045$ 

where:

V = avg. flow velocity (ft/s)

Q = flow rate (ft<sup>3</sup>/s)

A = square foot of pipe cross section

| Depth (ft)       | 1.0                            |       | 1.1  |       | 1.2   |       | 1.3   |       | 1.4   |       | 1.5   |       | 1.6   |       |
|------------------|--------------------------------|-------|------|-------|-------|-------|-------|-------|-------|-------|-------|-------|-------|-------|
|                  | X-sec. area (ft <sup>2</sup> ) | 8.00  | 9.02 | 10.08 | 11.18 | 12.32 | 13.50 | 14.72 | 15.96 | 17.20 | 18.44 | 19.68 | 20.92 | 22.16 |
| Hyd. radius (ft) | 0.76                           | 0.83  | 0.89 | 0.95  | 1.00  | 1.06  | 1.12  | 1.17  | 1.23  | 1.28  | 1.34  | 1.40  | 1.46  | 1.52  |
| S (ft/ft)        | V                              | Q     | V    | Q     | V     | Q     | V     | Q     | V     | Q     | V     | Q     | V     | Q     |
| .00005           | .19                            | 1.52  | .20  | 1.80  | .21   | 2.12  | .22   | 2.46  | .23   | 2.83  | .24   | 3.24  | .25   | 3.68  |
| .00010           | .27                            | 2.16  | .29  | 2.62  | .30   | 3.02  | .31   | 3.47  | .33   | 4.07  | .34   | 4.59  | .35   | 5.15  |
| .00015           | .34                            | 2.72  | .36  | 3.25  | .37   | 3.73  | .38   | 4.25  | .40   | 4.93  | .42   | 5.67  | .44   | 6.48  |
| .00020           | .38                            | 3.04  | .41  | 3.70  | .43   | 4.33  | .450  | 5.03  | .47   | 5.79  | .49   | 6.62  | .50   | 7.36  |
| .00025           | .43                            | 3.44  | .46  | 4.15  | .48   | 4.84  | .500  | 5.59  | .52   | 6.41  | .54   | 7.29  | .56   | 8.24  |
| .00030           | .47                            | 3.76  | .50  | 4.51  | .53   | 5.34  | .550  | 6.15  | .57   | 7.02  | .59   | 7.96  | .62   | 9.13  |
| .00035           | .51                            | 4.08  | .54  | 4.81  | .57   | 5.75  | .595  | 6.65  | .62   | 7.64  | .64   | 8.64  | .67   | 9.86  |
| .00040           | .55                            | 4.40  | .58  | 5.23  | .61   | 6.15  | .635  | 7.10  | .66   | 8.13  | .69   | 9.31  | .71   | 10.45 |
| .00045           | .58                            | 4.64  | .62  | 5.59  | .65   | 6.55  | .675  | 7.55  | .70   | 8.62  | .73   | 9.85  | .75   | 11.04 |
| .00050           | .62                            | 4.96  | .65  | 5.86  | .68   | 6.85  | .715  | 7.99  | .74   | 9.12  | .77   | 10.39 | .80   | 11.77 |
| .00055           | .65                            | 5.20  | .68  | 6.22  | .72   | 7.26  | .745  | 8.33  | .77   | 9.49  | .81   | 10.93 | .83   | 12.22 |
| .00060           | .68                            | 5.44  | .71  | 6.49  | .75   | 7.56  | .780  | 8.72  | .81   | 9.98  | .84   | 11.34 | .87   | 12.81 |
| .00065           | .70                            | 5.60  | .75  | 6.76  | .78   | 7.86  | .810  | 9.06  | .84   | 10.35 | .88   | 11.88 | .91   | 13.39 |
| .00070           | .72                            | 5.76  | .77  | 6.94  | .81   | 8.16  | .845  | 9.45  | .87   | 10.72 | .91   | 12.28 | .94   | 13.84 |
| .00075           | .75                            | 6.00  | .80  | 7.22  | .84   | 8.47  | .870  | 9.73  | .90   | 11.09 | .94   | 12.69 | .97   | 14.28 |
| .00080           | .77                            | 6.16  | .82  | 7.40  | .86   | 8.67  | .900  | 10.06 | .93   | 11.46 | .97   | 13.10 | 1.01  | 14.86 |
| .00085           | .80                            | 6.40  | .85  | 7.67  | .89   | 8.97  | .930  | 10.40 | .96   | 11.83 | 1.00  | 13.50 | 1.04  | 15.30 |
| .00090           | .82                            | 6.56  | .87  | 7.85  | .92   | 9.27  | .955  | 10.68 | .99   | 12.20 | 1.03  | 13.90 | 1.07  | 15.75 |
| .00095           | .85                            | 6.80  | .90  | 8.12  | .94   | 9.48  | .985  | 11.01 | 1.02  | 12.57 | 1.06  | 14.31 | 1.10  | 16.19 |
| .0010            | .87                            | 6.96  | .92  | 8.30  | .97   | 9.78  | 1.005 | 11.24 | 1.04  | 12.81 | 1.09  | 14.71 | 1.12  | 16.49 |
| .0011            | .91                            | 7.28  | .97  | 8.75  | 1.01  | 10.18 | 1.055 | 11.79 | 1.10  | 13.55 | 1.14  | 15.39 | 1.18  | 17.37 |
| .0012            | .95                            | 7.60  | 1.01 | 9.11  | 1.06  | 10.68 | 1.105 | 12.35 | 1.14  | 14.04 | 1.19  | 16.06 | 1.23  | 18.10 |
| .0013            | .99                            | 7.92  | 1.05 | 9.47  | 1.10  | 11.09 | 1.150 | 12.86 | 1.19  | 14.66 | 1.24  | 16.74 | 1.28  | 18.84 |
| .0014            | 1.03                           | 8.24  | 1.09 | 9.93  | 1.14  | 11.49 | 1.190 | 13.30 | 1.24  | 15.27 | 1.29  | 17.41 | 1.33  | 19.58 |
| .0015            | 1.06                           | 8.48  | 1.13 | 10.19 | 1.18  | 11.89 | 1.235 | 13.81 | 1.28  | 15.77 | 1.33  | 17.96 | 1.38  | 20.31 |
| .0016            | 1.10                           | 8.80  | 1.17 | 10.55 | 1.22  | 12.30 | 1.275 | 14.25 | 1.32  | 16.26 | 1.37  | 18.50 | 1.43  | 21.05 |
| .0017            | 1.13                           | 9.04  | 1.20 | 10.82 | 1.26  | 12.70 | 1.315 | 14.71 | 1.36  | 16.75 | 1.42  | 19.17 | 1.47  | 21.64 |
| .0018            | 1.17                           | 9.36  | 1.24 | 11.18 | 1.30  | 13.10 | 1.350 | 15.09 | 1.40  | 17.25 | 1.46  | 19.71 | 1.51  | 22.23 |
| .0019            | 1.20                           | 9.60  | 1.27 | 11.85 | 1.33  | 13.41 | 1.390 | 15.54 | 1.44  | 17.74 | 1.50  | 20.25 | 1.55  | 22.82 |
| .0020            | 1.23                           | 9.84  | 1.30 | 11.73 | 1.37  | 13.81 | 1.425 | 15.93 | 1.48  | 18.23 | 1.54  | 20.79 | 1.59  | 23.40 |
| .0021            | 1.26                           | 10.08 | 1.34 | 12.09 | 1.40  | 14.11 | 1.460 | 16.32 | 1.51  | 18.60 | 1.57  | 21.19 | 1.63  | 23.99 |
| .0022            | 1.29                           | 10.32 | 1.37 | 12.36 | 1.43  | 14.41 | 1.495 | 16.71 | 1.55  | 19.10 | 1.61  | 21.73 | 1.67  | 24.58 |
| .0023            | 1.32                           | 10.56 | 1.40 | 12.63 | 1.46  | 14.72 | 1.530 | 17.10 | 1.58  | 19.47 | 1.65  | 22.27 | 1.71  | 25.19 |
| .0024            | 1.34                           | 10.72 | 1.43 | 12.90 | 1.50  | 15.12 | 1.565 | 17.50 | 1.62  | 19.96 | 1.68  | 22.68 | 1.74  | 25.61 |
| .0025            | 1.37                           | 10.96 | 1.46 | 13.17 | 1.53  | 15.42 | 1.595 | 17.83 | 1.65  | 20.33 | 1.72  | 23.32 | 1.78  | 26.20 |

**Appendix 14A** Ditch design tables (sheet 6 of 10) using  $Q=VA$  with Manning's equation—continued

$$V = \frac{Q}{A}$$

where:  
 V = avg. flow velocity (ft/s)  
 Q = flow rate (ft<sup>3</sup>/s)  
 A = square foot of pipe cross section

Values of "V" and "Q" for trapezoidal ditches with 6-foot bottom, side slopes 2:1, n = .045

| Depth (ft)                     | 1.7   |       | 1.8   |       | 1.9   |       | 2.0   |       | 2.1   |       | 2.2   |       | 2.63  |       |
|--------------------------------|-------|-------|-------|-------|-------|-------|-------|-------|-------|-------|-------|-------|-------|-------|
| X-sec. area (ft <sup>2</sup> ) | 15.98 |       | 17.28 |       | 18.62 |       | 20.00 |       | 21.42 |       | 22.88 |       | 24.38 |       |
| Hyd. radius (ft)               | 1.17  |       | 1.23  |       | 1.28  |       | 1.34  |       | 1.39  |       | 1.44  |       | 1.49  |       |
| S (ft/ft)                      | V     | Q     | V     | Q     | V     | Q     | V     | Q     | V     | Q     | V     | Q     | V     | Q     |
| .00005                         | .25   | 4.00  | .26   | 4.49  | .27   | 5.03  | .28   | 5.60  | .29   | 6.21  | .29   | 6.64  | .30   | 7.31  |
| .00010                         | .36   | 5.75  | .38   | 6.57  | .39   | 7.26  | .40   | 8.00  | .41   | 8.78  | .42   | 9.61  | .43   | 10.48 |
| .00015                         | .45   | 7.19  | .47   | 8.12  | .48   | 8.94  | .49   | 9.80  | .51   | 10.92 | .52   | 11.90 | .53   | 12.92 |
| .00020                         | .518  | 8.28  | .536  | 9.26  | .546  | 10.17 | .567  | 11.34 | .581  | 12.44 | .592  | 13.54 | .607  | 14.80 |
| .00025                         | .579  | 9.25  | .599  | 10.35 | .614  | 11.43 | .632  | 12.64 | .647  | 13.86 | .662  | 15.15 | .677  | 16.50 |
| .00030                         | .635  | 10.15 | .659  | 11.39 | .674  | 12.55 | .696  | 13.92 | .716  | 15.34 | .732  | 16.75 | .747  | 18.21 |
| .00035                         | .686  | 10.96 | .709  | 12.25 | .724  | 13.48 | .746  | 14.92 | .766  | 16.41 | .786  | 17.98 | .806  | 19.65 |
| .00040                         | .733  | 11.71 | .762  | 13.17 | .782  | 14.56 | .806  | 16.12 | .826  | 17.69 | .842  | 19.26 | .857  | 20.89 |
| .00045                         | .777  | 12.41 | .802  | 13.86 | .822  | 15.31 | .85   | 17.00 | .875  | 18.74 | .896  | 20.50 | .916  | 22.33 |
| .00050                         | .819  | 13.08 | .842  | 14.55 | .862  | 16.05 | .897  | 17.94 | .915  | 19.60 | .941  | 21.53 | .963  | 23.48 |
| .00055                         | .859  | 13.73 | .885  | 15.29 | .910  | 16.94 | .94   | 18.80 | .965  | 20.67 | .986  | 22.56 | 1.006 | 24.53 |
| .00060                         | .897  | 14.33 | .925  | 15.98 | .95   | 17.69 | .98   | 19.60 | 1.005 | 21.53 | 1.030 | 23.57 | 1.055 | 25.72 |
| .00065                         | .934  | 14.92 | .965  | 16.67 | .99   | 18.43 | 1.02  | 20.40 | 1.045 | 22.38 | 1.070 | 24.48 | 1.095 | 26.70 |
| .00070                         | .969  | 15.48 | 1.005 | 17.37 | 1.03  | 19.18 | 1.06  | 21.20 | 1.085 | 23.24 | 1.110 | 25.40 | 1.135 | 27.67 |
| .00075                         | 1.003 | 16.03 | 1.035 | 17.88 | 1.06  | 19.74 | 1.094 | 21.88 | 1.124 | 24.08 | 1.150 | 26.31 | 1.175 | 28.65 |
| .00080                         | 1.036 | 16.55 | 1.068 | 18.45 | 1.098 | 20.44 | 1.134 | 22.68 | 1.164 | 24.93 | 1.190 | 27.23 | 1.215 | 29.62 |
| .00085                         | 1.068 | 17.06 | 1.105 | 19.09 | 1.13  | 21.04 | 1.164 | 23.28 | 1.194 | 25.57 | 1.224 | 28.01 | 1.254 | 30.57 |
| .00090                         | 1.099 | 17.56 | 1.138 | 19.66 | 1.168 | 21.75 | 1.204 | 24.08 | 1.234 | 26.43 | 1.264 | 28.92 | 1.294 | 31.55 |
| .00095                         | 1.129 | 18.04 | 1.168 | 20.18 | 1.198 | 22.31 | 1.234 | 24.68 | 1.264 | 27.07 | 1.294 | 29.61 | 1.324 | 32.23 |
| .0010                          | 1.159 | 18.52 | 1.198 | 20.70 | 1.228 | 22.86 | 1.268 | 25.36 | 1.303 | 27.91 | 1.334 | 30.52 | 1.364 | 33.25 |
| .0011                          | 1.216 | 19.43 | 1.258 | 21.74 | 1.288 | 23.98 | 1.328 | 26.56 | 1.363 | 29.20 | 1.394 | 31.89 | 1.424 | 34.72 |
| .0012                          | 1.269 | 20.28 | 1.311 | 22.65 | 1.346 | 25.06 | 1.384 | 27.68 | 1.423 | 30.48 | 1.458 | 33.36 | 1.493 | 36.40 |
| .0013                          | 1.319 | 21.08 | 1.364 | 23.57 | 1.404 | 26.14 | 1.448 | 28.96 | 1.483 | 31.77 | 1.518 | 34.73 | 1.553 | 37.86 |
| .0014                          | 1.371 | 21.91 | 1.414 | 24.43 | 1.454 | 27.07 | 1.502 | 30.04 | 1.542 | 33.03 | 1.578 | 36.10 | 1.613 | 39.33 |
| .0015                          | 1.419 | 22.68 | 1.464 | 25.30 | 1.504 | 28.00 | 1.552 | 31.04 | 1.592 | 34.10 | 1.628 | 37.25 | 1.663 | 40.54 |
| .0016                          | 1.466 | 23.43 | 1.514 | 26.16 | 1.554 | 28.94 | 1.602 | 32.04 | 1.642 | 35.17 | 1.682 | 38.48 | 1.722 | 41.98 |
| .0017                          | 1.511 | 24.14 | 1.564 | 27.02 | 1.604 | 29.87 | 1.652 | 33.04 | 1.692 | 36.24 | 1.732 | 39.63 | 1.772 | 43.20 |
| .0018                          | 1.555 | 24.85 | 1.607 | 27.77 | 1.652 | 30.76 | 1.702 | 34.04 | 1.742 | 37.31 | 1.782 | 40.77 | 1.822 | 44.42 |
| .0019                          | 1.60  | 25.57 | 1.654 | 28.58 | 1.694 | 31.54 | 1.746 | 34.92 | 1.791 | 38.36 | 1.836 | 42.01 | 1.881 | 45.86 |
| .0020                          | 1.64  | 26.21 | 1.697 | 29.32 | 1.742 | 32.43 | 1.796 | 35.92 | 1.841 | 39.43 | 1.882 | 43.06 | 1.922 | 46.86 |
| .0021                          | 1.68  | 26.85 | 1.737 | 30.01 | 1.782 | 33.18 | 1.836 | 36.72 | 1.881 | 40.29 | 1.926 | 44.07 | 1.971 | 48.05 |
| .0022                          | 1.72  | 27.49 | 1.777 | 30.70 | 1.822 | 33.93 | 1.88  | 37.60 | 1.930 | 41.34 | 1.976 | 45.21 | 2.021 | 49.27 |
| .0023                          | 1.76  | 28.12 | 1.82  | 31.45 | 1.870 | 34.82 | 1.926 | 38.52 | 1.971 | 42.22 | 2.016 | 46.13 | 2.061 | 50.25 |
| .0024                          | 1.795 | 28.68 | 1.86  | 32.14 | 1.910 | 35.56 | 1.966 | 39.32 | 2.011 | 43.08 | 2.060 | 47.13 | 2.110 | 51.44 |
| .0025                          | 1.83  | 29.24 | 1.893 | 32.71 | 1.948 | 36.27 | 2.01  | 40.20 | 2.060 | 44.12 | 2.106 | 48.19 | 2.151 | 52.44 |

**Appendix 14A** Ditch design tables (sheet 7 of 10) using  $Q=VA$  with Manning's equation—continued

$$V = \frac{Q}{A}$$

where:

V = avg. flow velocity (ft/s)

Q = flow rate (ft<sup>3</sup>/s)

A = square foot of pipe cross section

Values of "V" and "Q" for trapezoidal ditches with 6-foot bottom, side slopes 2:1, n = .045

| Depth (ft)                     | 2.4   |       | 2.5   |       | 2.6   |       | 2.7   |       | 2.8   |       | 2.9   |       | 3.0   |       |
|--------------------------------|-------|-------|-------|-------|-------|-------|-------|-------|-------|-------|-------|-------|-------|-------|
|                                | V     | Q     | V     | Q     | V     | Q     | V     | Q     | V     | Q     | V     | Q     | V     | Q     |
| X-sec. area (ft <sup>2</sup> ) | 25.92 |       | 27.50 |       | 29.12 |       | 30.78 |       | 32.48 |       | 34.22 |       | 36.00 |       |
| Hyd. radius (ft)               | 1.55  |       | 1.60  |       | 1.65  |       | 1.70  |       | 1.75  |       | 1.80  |       | 1.85  |       |
| S (ft/ft)                      | V     | Q     | V     | Q     | V     | Q     | V     | Q     | V     | Q     | V     | Q     | V     | Q     |
| .00005                         | .31   | 8.04  | .32   | 8.80  | .325  | 9.46  | .33   | 10.16 | .34   | 11.04 | .35   | 11.98 | .355  | 12.78 |
| .00010                         | .44   | 11.40 | .45   | 12.37 | .46   | 13.39 | .47   | 14.47 | .48   | 15.59 | .49   | 16.77 | .495  | 17.82 |
| .00015                         | .54   | 14.00 | .55   | 15.12 | .56   | 16.31 | .57   | 17.54 | .58   | 18.84 | .60   | 20.53 | .61   | 21.96 |
| .00020                         | .62   | 16.07 | .64   | 17.60 | .65   | 18.93 | .66   | 20.31 | .67   | 21.76 | .69   | 23.61 | .70   | 25.20 |
| .00025                         | .69   | 17.88 | .71   | 19.52 | .72   | 20.97 | .74   | 22.78 | .75   | 24.36 | .77   | 26.35 | .78   | 28.08 |
| .00030                         | .76   | 19.70 | .78   | 21.45 | .79   | 23.00 | .81   | 24.93 | .83   | 26.96 | .85   | 29.09 | .86   | 30.96 |
| .00035                         | .83   | 21.51 | .85   | 23.37 | .86   | 25.04 | .88   | 27.09 | .89   | 28.91 | .91   | 31.14 | .92   | 33.12 |
| .00040                         | .88   | 22.81 | .90   | 24.75 | .92   | 26.79 | .94   | 28.93 | .96   | 31.18 | .98   | 33.54 | .99   | 35.64 |
| .00045                         | .94   | 24.36 | .96   | 26.40 | .98   | 28.54 | 1.00  | 30.78 | 1.02  | 33.13 | 1.04  | 35.59 | 1.05  | 37.80 |
| .00050                         | .98   | 25.40 | 1.01  | 27.77 | 1.03  | 29.99 | 1.05  | 32.32 | 1.07  | 34.75 | 1.09  | 37.30 | 1.11  | 39.96 |
| .00055                         | 1.03  | 26.70 | 1.06  | 29.15 | 1.08  | 31.45 | 1.10  | 33.86 | 1.12  | 36.38 | 1.15  | 39.35 | 1.17  | 42.12 |
| .00060                         | 1.08  | 27.99 | 1.11  | 30.52 | 1.13  | 32.91 | 1.15  | 35.40 | 1.17  | 38.00 | 1.20  | 41.06 | 1.22  | 43.92 |
| .00065                         | 1.12  | 29.03 | 1.15  | 31.62 | 1.17  | 34.07 | 1.20  | 36.94 | 1.22  | 39.63 | 1.25  | 42.77 | 1.27  | 45.72 |
| .00070                         | 1.15  | 29.81 | 1.20  | 33.00 | 1.22  | 35.53 | 1.24  | 38.17 | 1.26  | 40.92 | 1.29  | 44.14 | 1.31  | 47.16 |
| .00075                         | 1.21  | 31.36 | 1.24  | 34.10 | 1.26  | 36.69 | 1.29  | 39.71 | 1.31  | 42.55 | 1.34  | 45.85 | 1.36  | 48.96 |
| .00080                         | 1.25  | 32.40 | 1.28  | 35.20 | 1.30  | 37.86 | 1.33  | 40.94 | 1.35  | 43.85 | 1.38  | 47.22 | 1.40  | 50.40 |
| .00085                         | 1.29  | 33.44 | 1.32  | 36.30 | 1.34  | 39.02 | 1.37  | 42.17 | 1.39  | 45.15 | 1.42  | 48.59 | 1.44  | 51.84 |
| .00090                         | 1.33  | 34.47 | 1.36  | 37.40 | 1.38  | 40.18 | 1.41  | 43.40 | 1.44  | 46.77 | 1.47  | 50.30 | 1.49  | 53.64 |
| .00095                         | 1.36  | 35.25 | 1.39  | 38.22 | 1.42  | 46.35 | 1.45  | 44.63 | 1.48  | 48.07 | 1.51  | 51.67 | 1.53  | 55.08 |
| .0010                          | 1.40  | 36.29 | 1.43  | 39.32 | 1.46  | 42.51 | 1.49  | 45.86 | 1.52  | 49.37 | 1.55  | 53.04 | 1.57  | 56.52 |
| .0011                          | 1.46  | 37.84 | 1.50  | 41.25 | 1.53  | 44.56 | 1.56  | 48.02 | 1.59  | 51.64 | 1.62  | 55.44 | 1.65  | 59.40 |
| .0012                          | 1.53  | 39.66 | 1.56  | 42.90 | 1.59  | 46.30 | 1.63  | 50.17 | 1.66  | 53.92 | 1.69  | 57.83 | 1.72  | 61.92 |
| .0013                          | 1.59  | 41.21 | 1.63  | 44.82 | 1.66  | 48.34 | 1.69  | 52.02 | 1.72  | 55.87 | 1.76  | 60.23 | 1.79  | 64.44 |
| .0014                          | 1.66  | 43.03 | 1.69  | 46.47 | 1.72  | 50.09 | 1.76  | 54.17 | 1.79  | 58.14 | 1.83  | 62.62 | 1.86  | 66.96 |
| .0015                          | 1.71  | 44.32 | 1.75  | 48.12 | 1.78  | 51.83 | 1.82  | 56.02 | 1.85  | 60.09 | 1.89  | 64.68 | 1.92  | 69.12 |
| .0016                          | 1.76  | 45.62 | 1.80  | 49.50 | 1.84  | 53.58 | 1.88  | 57.87 | 1.91  | 62.04 | 1.95  | 66.73 | 1.99  | 71.64 |
| .0017                          | 1.82  | 47.43 | 1.86  | 51.15 | 1.90  | 55.33 | 1.94  | 59.71 | 1.97  | 63.99 | 2.01  | 68.78 | 2.05  | 73.80 |
| .0018                          | 1.86  | 48.21 | 1.91  | 52.52 | 1.95  | 56.78 | 1.99  | 61.25 | 2.03  | 65.93 | 2.07  | 70.84 | 2.11  | 75.96 |
| .0019                          | 1.93  | 50.03 | 1.97  | 54.17 | 2.01  | 58.53 | 2.05  | 63.10 | 2.09  | 67.88 | 2.13  | 72.89 | 2.15  | 77.40 |
| .0020                          | 1.97  | 51.06 | 2.02  | 55.55 | 2.06  | 59.99 | 2.10  | 64.64 | 2.14  | 69.51 | 2.19  | 74.94 | 2.23  | 80.28 |

**Appendix 14A** Ditch design tables (sheet 8 of 10) using  $Q=VA$  with Manning's equation—continued

$$V = \frac{Q}{A}$$

Values of "V" and "Q" for trapezoidal ditches with 6-foot bottom, side slopes 2:1,  $n = .045$

where:  
V = avg. flow velocity (ft/s)  
Q = flow rate (ft<sup>3</sup>/s)  
A = square foot of pipe cross section

| Depth (ft)                     | 3.1   |       | 3.2   |       | 3.3   |       | 3.4   |        | 3.5   |        | 3.6   |        | 3.7   |        | 3.8   |        |
|--------------------------------|-------|-------|-------|-------|-------|-------|-------|--------|-------|--------|-------|--------|-------|--------|-------|--------|
| X-sec. area (ft <sup>2</sup> ) | 37.82 |       | 39.68 |       | 41.58 |       | 43.52 |        | 45.50 |        | 47.52 |        | 49.58 |        | 51.68 |        |
| Hyd. radius (ft)               | 1.90  |       | 1.95  |       | 2.00  |       | 2.05  |        | 2.10  |        | 2.15  |        | 2.19  |        | 3.25  |        |
| S (ft/ft)                      | V     | Q     | V     | Q     | V     | Q     | V     | Q      | V     | Q      | V     | Q      | V     | Q      | V     | Q      |
| .00005                         | .36   | 13.61 | .365  | 14.48 | .37   | 15.38 | .375  | 16.32  | .38   | 17.29  | .385  | 18.30  | .39   | 19.34  | .39   | 20.16  |
| .00010                         | .50   | 18.91 | .51   | 20.24 | .52   | 21.62 | .53   | 23.06  | .54   | 24.57  | .55   | 26.14  | .56   | 27.76  | .56   | 28.94  |
| .00015                         | .62   | 23.45 | .63   | 25.00 | .64   | 26.61 | .65   | 28.29  | .66   | 30.03  | .67   | 31.84  | .68   | 33.71  | .69   | 35.66  |
| .00020                         | .71   | 26.85 | .725  | 28.77 | .74   | 30.77 | .75   | 32.64  | .76   | 34.58  | .77   | 36.59  | .79   | 39.17  | .80   | 41.34  |
| .00025                         | .80   | 30.26 | .815  | 32.34 | .83   | 34.51 | .84   | 36.56  | .85   | 38.67  | .86   | 40.87  | .88   | 43.63  | .89   | 46.00  |
| .00030                         | .88   | 33.28 | .895  | 35.51 | .91   | 37.84 | .92   | 40.04  | .94   | 42.77  | .95   | 45.14  | .97   | 48.09  | .98   | 50.65  |
| .00035                         | .94   | 35.55 | .96   | 38.09 | .98   | 40.75 | .99   | 43.08  | 1.01  | 45.95  | 1.03  | 48.95  | 1.05  | 52.06  | 1.06  | 54.78  |
| .00040                         | 1.01  | 38.20 | 1.03  | 40.87 | 1.05  | 43.66 | 1.06  | 46.13  | 1.08  | 49.14  | 1.10  | 52.27  | 1.12  | 55.53  | 1.13  | 58.40  |
| .00045                         | 1.07  | 40.47 | 1.09  | 43.25 | 1.11  | 46.15 | 1.12  | 48.74  | 1.14  | 51.87  | 1.16  | 55.12  | 1.18  | 58.50  | 1.20  | 62.02  |
| .00050                         | 1.13  | 42.74 | 1.15  | 45.63 | 1.17  | 48.65 | 1.19  | 51.79  | 1.21  | 55.05  | 1.23  | 58.45  | 1.25  | 61.48  | 1.26  | 65.12  |
| .00055                         | 1.19  | 45.01 | 1.21  | 48.01 | 1.23  | 51.14 | 1.25  | 54.40  | 1.27  | 57.78  | 1.29  | 61.30  | 1.31  | 64.45  | 1.33  | 68.73  |
| .00060                         | 1.24  | 46.90 | 1.26  | 50.00 | 1.28  | 53.22 | 1.30  | 56.58  | 1.32  | 60.06  | 1.34  | 63.68  | 1.36  | 67.43  | 1.39  | 71.84  |
| .00065                         | 1.29  | 48.79 | 1.31  | 51.98 | 1.34  | 55.72 | 1.36  | 59.19  | 1.38  | 62.79  | 1.40  | 66.53  | 1.41  | 69.91  | 1.44  | 74.42  |
| .00070                         | 1.34  | 50.68 | 1.36  | 53.96 | 1.39  | 57.80 | 1.41  | 61.36  | 1.43  | 65.06  | 1.45  | 68.90  | 1.47  | 72.88  | 1.50  | 77.52  |
| .00075                         | 1.39  | 52.57 | 1.41  | 55.95 | 1.44  | 59.88 | 1.46  | 63.54  | 1.48  | 67.34  | 1.50  | 71.28  | 1.52  | 75.36  | 1.55  | 80.10  |
| .00080                         | 1.43  | 54.08 | 1.45  | 57.54 | 1.48  | 61.54 | 1.50  | 65.28  | 1.53  | 69.61  | 1.55  | 73.66  | 1.57  | 77.84  | 1.60  | 82.69  |
| .00085                         | 1.47  | 55.60 | 1.50  | 59.52 | 1.53  | 63.62 | 1.55  | 67.46  | 1.58  | 71.89  | 1.60  | 76.03  | 1.62  | 80.32  | 1.65  | 85.27  |
| .00090                         | 1.52  | 57.49 | 1.54  | 61.11 | 1.57  | 65.28 | 1.59  | 69.20  | 1.62  | 73.71  | 1.65  | 78.41  | 1.67  | 82.80  | 1.70  | 87.86  |
| .00095                         | 1.56  | 59.00 | 1.59  | 63.09 | 1.62  | 67.36 | 1.64  | 71.37  | 1.67  | 75.98  | 1.69  | 80.31  | 1.71  | 84.78  | 1.74  | 89.92  |
| .00100                         | 1.60  | 60.51 | 1.63  | 64.68 | 1.66  | 69.02 | 1.68  | 73.11  | 1.71  | 77.80  | 1.74  | 82.68  | 1.76  | 87.26  | 1.79  | 92.51  |
| .0011                          | 1.68  | 63.54 | 1.71  | 67.85 | 1.74  | 72.35 | 1.76  | 76.60  | 1.79  | 81.44  | 1.82  | 86.49  | 1.84  | 91.23  | 1.87  | 96.64  |
| .0012                          | 1.75  | 66.18 | 1.78  | 70.63 | 1.82  | 75.68 | 1.85  | 80.52  | 1.88  | 85.54  | 1.90  | 90.29  | 1.92  | 95.19  | 1.95  | 100.78 |
| .0013                          | 1.83  | 69.21 | 1.86  | 73.80 | 1.89  | 78.59 | 1.92  | 83.56  | 1.95  | 88.72  | 1.98  | 94.09  | 2.00  | 99.16  | 2.03  | 104.91 |
| .0014                          | 1.89  | 71.48 | 1.92  | 76.19 | 1.96  | 81.50 | 1.99  | 86.60  | 2.03  | 92.36  | 2.06  | 97.89  | 2.08  | 103.13 | 2.11  | 109.04 |
| .0015                          | 1.96  | 74.13 | 1.99  | 78.96 | 2.03  | 84.41 | 2.06  | 89.65  | 2.09  | 95.09  | 2.12  | 100.74 | 2.15  | 106.60 | 2.18  | 112.66 |
| .0016                          | 2.03  | 76.77 | 2.06  | 81.74 | 2.10  | 87.32 | 2.13  | 92.70  | 2.17  | 98.73  | 2.20  | 105.54 | 2.22  | 110.07 | 2.26  | 116.80 |
| .0017                          | 2.09  | 79.04 | 2.12  | 84.12 | 2.16  | 89.81 | 2.19  | 95.31  | 2.23  | 101.46 | 2.26  | 107.40 | 2.29  | 113.54 | 2.33  | 120.41 |
| .0018                          | 2.15  | 81.31 | 2.18  | 86.50 | 2.22  | 92.31 | 2.26  | 98.36  | 2.30  | 104.65 | 2.33  | 110.72 | 2.36  | 117.01 | 2.40  | 124.03 |
| .0019                          | 2.21  | 83.58 | 2.24  | 88.88 | 2.28  | 94.80 | 2.32  | 100.97 | 2.36  | 107.38 | 2.39  | 113.57 | 2.42  | 119.98 | 2.46  | 127.13 |
| .0020                          | 2.27  | 85.85 | 2.30  | 91.26 | 2.34  | 97.30 | 2.37  | 103.14 | 2.42  | 110.11 | 2.46  | 116.90 | 2.49  | 123.45 | 2.53  | 130.75 |



**Appendix 14A** Ditch design tables (sheet 9 of 10) using  $Q=VA$  with Manning's equation—continued  $V = \frac{Q}{A}$ Values of "V" and "Q" for trapezoidal ditches with 6-foot bottom, side slopes 2:1,  $n = .045$ 

where:

V = avg. flow velocity (ft/s)

Q = flow rate (ft<sup>3</sup>/s)

A = square foot of pipe cross section

| Depth in ft.<br>X-sec. area<br>Hyd. radius<br>S (ft/ft) | 3.9<br>53.82<br>2.29 |        | 4.0<br>56.00<br>2.34 |        | 4.1<br>58.22<br>2.39 |        | 4.2<br>60.48<br>2.44 |        | 4.3<br>62.78<br>2.49 |        | 4.4<br>65.12<br>2.53 |        | 4.5<br>67.50<br>2.58 |        | 4.6<br>69.92<br>2.63 |        |
|---|----------------------|--------|----------------------|--------|----------------------|--------|----------------------|--------|----------------------|--------|----------------------|--------|----------------------|--------|----------------------|--------|
|   | V                    | Q      | V                    | Q      | V                    | Q      | V                    | Q      | V                    | Q      | V                    | Q      | V                    | Q      | V                    | Q      |
| .00005  | .40                  | 21.53  | .41                  | 22.96  | .42                  | 24.45  | .42                  | 25.40  | .43                  | 27.00  | .49                  | 31.91  | .50                  | 33.75  | .50                  | 34.96  |
| .00010  | .57                  | 30.68  | .58                  | 32.48  | .59                  | 34.35  | .59                  | 35.68  | .60                  | 37.67  | .69                  | 44.93  | .70                  | 47.25  | .71                  | 49.64  |
| .00015  | .70                  | 37.67  | .71                  | 39.76  | .72                  | 41.92  | .73                  | 44.15  | .74                  | 46.46  | .85                  | 55.35  | .86                  | 58.05  | .87                  | 60.83  |
| .00020  | .81                  | 43.59  | .82                  | 45.92  | .84                  | 48.90  | .85                  | 51.41  | .86                  | 53.99  | .97                  | 63.17  | .98                  | 66.15  | 1.00                 | 69.92  |
| .00025  | .91                  | 48.98  | .92                  | 51.52  | .94                  | 54.73  | .95                  | 57.46  | .96                  | 60.27  | 1.09                 | 70.98  | 1.10                 | 74.25  | 1.12                 | 78.31  |
| .00030  | 1.00                 | 53.82  | 1.01                 | 56.56  | 1.03                 | 59.97  | 1.04                 | 62.90  | 1.05                 | 65.92  | 1.19                 | 77.49  | 1.21                 | 81.67  | 1.23                 | 86.00  |
| .00035  | 1.08                 | 58.13  | 1.09                 | 61.04  | 1.11                 | 64.62  | 1.12                 | 67.74  | 1.14                 | 71.57  | 1.29                 | 84.00  | 1.30                 | 87.75  | 1.32                 | 92.29  |
| .00040  | 1.15                 | 61.89  | 1.16                 | 64.96  | 1.18                 | 68.70  | 1.19                 | 71.97  | 1.21                 | 75.96  | 1.37                 | 89.21  | 1.39                 | 93.82  | 1.41                 | 98.59  |
| .00045  | 1.22                 | 65.66  | 1.24                 | 69.44  | 1.26                 | 73.36  | 1.27                 | 76.81  | 1.29                 | 80.99  | 1.46                 | 95.08  | 1.48                 | 99.90  | 1.50                 | 104.88 |
| .00050  | 1.28                 | 68.89  | 1.30                 | 72.80  | 1.32                 | 76.85  | 1.34                 | 80.44  | 1.36                 | 85.38  | 1.54                 | 100.28 | 1.56                 | 105.30 | 1.58                 | 110.47 |
| .00055  | 1.35                 | 72.66  | 1.37                 | 76.72  | 1.39                 | 80.93  | 1.40                 | 84.67  | 1.42                 | 89.15  | 1.62                 | 105.49 | 1.64                 | 110.70 | 1.66                 | 116.08 |
| .00060  | 1.41                 | 75.89  | 1.43                 | 80.08  | 1.45                 | 84.42  | 1.47                 | 88.91  | 1.49                 | 93.54  | 1.69                 | 110.05 | 1.71                 | 115.42 | 1.74                 | 121.66 |
| .00065  | 1.46                 | 78.58  | 1.48                 | 82.88  | 1.51                 | 87.91  | 1.53                 | 92.53  | 1.55                 | 97.31  | 1.76                 | 114.61 | 1.78                 | 120.15 | 1.80                 | 125.86 |
| .00070  | 1.52                 | 81.81  | 1.54                 | 86.24  | 1.57                 | 91.41  | 1.59                 | 96.16  | 1.61                 | 101.08 | 1.83                 | 119.17 | 1.85                 | 124.87 | 1.87                 | 130.75 |
| .00075  | 1.57                 | 84.50  | 1.59                 | 89.04  | 1.62                 | 94.32  | 1.64                 | 99.19  | 1.66                 | 104.21 | 1.89                 | 123.08 | 1.91                 | 128.92 | 1.94                 | 135.64 |
| .00080  | 1.62                 | 87.19  | 1.64                 | 91.84  | 1.67                 | 97.23  | 1.69                 | 102.21 | 1.72                 | 107.98 | 1.95                 | 126.98 | 1.97                 | 132.97 | 2.01                 | 140.54 |
| .00085  | 1.68                 | 90.42  | 1.70                 | 95.20  | 1.73                 | 100.72 | 1.75                 | 105.84 | 1.77                 | 111.12 | 2.01                 | 130.89 | 2.04                 | 137.70 | 2.07                 | 144.73 |
| .00090  | 1.73                 | 93.11  | 1.75                 | 98.00  | 1.78                 | 103.63 | 1.80                 | 108.86 | 1.82                 | 114.26 | 2.07                 | 134.80 | 2.10                 | 141.75 | 2.13                 | 148.93 |
| .00095  | 1.77                 | 95.26  | 1.79                 | 100.24 | 1.82                 | 105.96 | 1.84                 | 111.28 | 1.87                 | 117.40 | 2.16                 | 138.71 | 2.16                 | 145.80 | 2.19                 | 153.12 |
| .00100  | 1.82                 | 97.95  | 1.84                 | 103.04 | 1.87                 | 108.87 | 1.89                 | 114.31 | 1.92                 | 120.54 | 2.18                 | 141.96 | 2.21                 | 149.17 | 2.24                 | 156.62 |
| .0011   | 1.90                 | 102.26 | 1.93                 | 108.08 | 1.96                 | 114.11 | 1.98                 | 119.75 | 2.01                 | 126.19 | 2.29                 | 149.12 | 2.32                 | 156.60 | 2.35                 | 164.31 |
| .0012   | 1.98                 | 106.56 | 2.01                 | 112.56 | 2.04                 | 118.77 | 2.07                 | 125.19 | 2.10                 | 131.84 | 2.39                 | 155.64 | 2.42                 | 163.35 | 2.45                 | 171.30 |
| .0013   | 2.06                 | 110.87 | 2.09                 | 117.04 | 2.12                 | 123.43 | 2.15                 | 130.03 | 2.18                 | 136.86 | 2.49                 | 162.15 | 2.52                 | 170.10 | 2.55                 | 178.30 |
| .0014   | 2.14                 | 115.17 | 2.17                 | 121.52 | 2.20                 | 128.08 | 2.23                 | 134.87 | 2.26                 | 141.88 | 2.58                 | 168.01 | 2.62                 | 176.85 | 2.65                 | 185.29 |
| .0015   | 2.21                 | 118.94 | 2.25                 | 126.00 | 2.28                 | 132.74 | 2.31                 | 139.71 | 2.34                 | 146.91 | 2.67                 | 173.87 | 2.71                 | 182.92 | 2.74                 | 191.58 |
| .0016   | 2.29                 | 123.25 | 2.33                 | 130.48 | 2.36                 | 137.40 | 2.39                 | 144.55 | 2.42                 | 151.93 | 2.76                 | 179.73 | 2.80                 | 189.00 | 2.83                 | 197.87 |
| .0017   | 2.36                 | 127.02 | 2.40                 | 134.40 | 2.43                 | 141.47 | 2.47                 | 149.39 | 2.50                 | 156.95 | 2.85                 | 185.59 | 2.89                 | 195.07 | 2.93                 | 204.87 |
| .0018   | 2.43                 | 130.78 | 2.47                 | 138.32 | 2.50                 | 145.55 | 2.54                 | 153.62 | 2.57                 | 161.34 | 2.92                 | 190.15 | 2.96                 | 199.80 | 3.00                 | 209.76 |
| .0019   | 2.50                 | 134.55 | 2.54                 | 142.24 | 2.57                 | 149.63 | 2.61                 | 157.85 | 2.64                 | 165.74 | 3.00                 | 195.36 | 3.04                 | 205.20 | 3.08                 | 215.35 |
| .0020   | 2.56                 | 137.78 | 2.60                 | 145.60 | 2.64                 | 153.70 | 2.68                 | 162.09 | 2.71                 | 170.13 | 3.08                 | 200.57 | 3.12                 | 210.60 | 3.16                 | 220.95 |

**Appendix 14A** Ditch design tables (sheet 10 of 10) using  $Q=VA$  with Manning's equation—continued  $V = \frac{Q}{A}$

Values of "V" and "Q" for trapezoidal ditches with 6-foot bottom, side slopes 2:1,  $n = .040$

where:  
V = avg. flow velocity (ft/s)  
Q = flow rate (ft<sup>3</sup>/s)  
A = square foot of pipe cross section

| Depth (ft)                     | 4.7   |        | 4.8   |        | 4.9   |        | 5.0   |        | 5.1   |        | 5.2   |        | 5.3   |        | 5.4   |        |
|--------------------------------|-------|--------|-------|--------|-------|--------|-------|--------|-------|--------|-------|--------|-------|--------|-------|--------|
| X-sec. area (ft <sup>2</sup> ) | 72.38 |        | 74.88 |        | 77.42 |        | 80.00 |        | 82.62 |        | 85.28 |        | 87.98 |        | 90.72 |        |
| Hyd. radius (ft)               | 2.68  |        | 2.72  |        | 2.77  |        | 2.82  |        | 2.87  |        | 2.91  |        | 2.96  |        | 3.01  |        |
| S (ft/ft)                      | V     | Q      | V     | Q      | V     | Q      | V     | Q      | V     | Q      | V     | Q      | V     | Q      | V     | Q      |
| .00005                         | .51   | 36.91  | .51   | 38.19  | .52   | 40.26  | .52   | 41.60  | .53   | 43.79  | .54   | 46.05  | .54   | 47.50  | .55   | 49.90  |
| .00010                         | .72   | 52.11  | .72   | 53.91  | .73   | 56.52  | .74   | 59.20  | .75   | 61.96  | .76   | 64.81  | .77   | 67.74  | .77   | 69.85  |
| .00015                         | .88   | 63.69  | .88   | 65.89  | .89   | 68.90  | .91   | 72.80  | .92   | 76.01  | .93   | 79.31  | .94   | 82.70  | .95   | 86.18  |
| .00020                         | 1.01  | 73.10  | 1.02  | 76.38  | 1.03  | 79.74  | 1.04  | 83.20  | 1.05  | 86.75  | 1.06  | 90.40  | 1.08  | 95.02  | 1.09  | 98.88  |
| .00025                         | 1.13  | 81.79  | 1.15  | 86.11  | 1.16  | 89.81  | 1.17  | 93.60  | 1.18  | 97.49  | 1.19  | 101.48 | 1.21  | 106.46 | 1.22  | 110.68 |
| .00030                         | 1.24  | 89.75  | 1.26  | 94.35  | 1.27  | 98.32  | 1.29  | 103.20 | 1.30  | 107.41 | 1.31  | 111.72 | 1.33  | 117.01 | 1.34  | 121.56 |
| .00035                         | 1.33  | 96.27  | 1.35  | 101.09 | 1.37  | 106.07 | 1.39  | 111.20 | 1.40  | 115.67 | 1.41  | 120.24 | 1.43  | 125.81 | 1.45  | 131.54 |
| .00040                         | 1.43  | 103.50 | 1.45  | 108.58 | 1.47  | 113.81 | 1.49  | 119.20 | 1.50  | 123.93 | 1.51  | 128.77 | 1.58  | 134.61 | 1.55  | 140.62 |
| .00045                         | 1.52  | 110.02 | 1.54  | 115.32 | 1.56  | 120.78 | 1.58  | 126.40 | 1.59  | 131.37 | 1.60  | 136.45 | 1.62  | 142.53 | 1.64  | 148.78 |
| .00050                         | 1.60  | 115.81 | 1.62  | 121.31 | 1.64  | 126.97 | 1.66  | 132.80 | 1.68  | 138.80 | 1.69  | 144.12 | 1.71  | 150.45 | 1.73  | 156.95 |
| .00055                         | 1.68  | 121.60 | 1.70  | 127.30 | 1.72  | 133.16 | 1.74  | 139.20 | 1.76  | 145.41 | 1.77  | 150.95 | 1.79  | 157.48 | 1.81  | 164.20 |
| .00060                         | 1.76  | 127.39 | 1.78  | 133.29 | 1.80  | 139.36 | 1.82  | 145.60 | 1.84  | 152.02 | 1.85  | 157.77 | 1.87  | 164.52 | 1.90  | 172.37 |
| .00065                         | 1.82  | 131.73 | 1.84  | 137.78 | 1.87  | 144.78 | 1.89  | 151.20 | 1.91  | 157.80 | 1.93  | 164.59 | 1.95  | 171.56 | 1.97  | 178.72 |
| .00070                         | 1.89  | 136.80 | 1.91  | 143.02 | 1.94  | 150.19 | 1.96  | 156.80 | 1.98  | 163.59 | 2.00  | 170.56 | 2.02  | 177.72 | 2.04  | 185.07 |
| .00075                         | 1.96  | 141.86 | 1.98  | 148.26 | 2.01  | 155.61 | 2.03  | 162.40 | 2.06  | 170.20 | 2.08  | 177.38 | 2.10  | 184.76 | 2.12  | 192.33 |
| .00080                         | 2.03  | 146.93 | 2.05  | 153.50 | 2.08  | 161.03 | 2.10  | 168.00 | 2.13  | 175.98 | 2.15  | 183.35 | 2.17  | 190.92 | 2.19  | 198.68 |
| .00085                         | 2.09  | 151.27 | 2.11  | 158.00 | 2.14  | 165.68 | 2.16  | 172.80 | 2.19  | 180.94 | 2.21  | 188.47 | 2.23  | 196.20 | 2.26  | 205.03 |
| .00090                         | 2.15  | 155.62 | 2.17  | 162.49 | 2.20  | 170.32 | 2.22  | 177.60 | 2.25  | 185.89 | 2.27  | 193.59 | 2.30  | 202.35 | 2.33  | 211.38 |
| .00095                         | 2.21  | 159.96 | 2.23  | 166.98 | 2.26  | 174.97 | 2.28  | 182.40 | 2.31  | 190.85 | 2.33  | 198.70 | 2.36  | 207.63 | 2.39  | 216.82 |
| .00100                         | 2.26  | 163.58 | 2.28  | 170.73 | 2.32  | 179.61 | 2.34  | 187.20 | 2.37  | 195.81 | 2.39  | 203.82 | 2.42  | 212.91 | 2.45  | 222.26 |
| .0011                          | 2.38  | 172.26 | 2.40  | 179.71 | 2.43  | 188.13 | 2.46  | 196.80 | 2.49  | 205.72 | 2.52  | 214.91 | 2.54  | 223.47 | 2.57  | 233.15 |
| .0012                          | 2.49  | 180.23 | 2.51  | 187.95 | 2.54  | 196.65 | 2.57  | 205.60 | 2.60  | 214.81 | 2.63  | 224.29 | 2.66  | 234.03 | 2.69  | 244.04 |
| .0013                          | 2.59  | 187.46 | 2.61  | 195.44 | 2.64  | 204.39 | 2.67  | 213.60 | 2.70  | 223.07 | 2.73  | 232.81 | 2.76  | 242.82 | 2.80  | 254.02 |
| .0014                          | 2.69  | 194.70 | 2.71  | 202.92 | 2.74  | 212.13 | 2.77  | 221.60 | 2.81  | 232.16 | 2.84  | 242.20 | 2.86  | 251.62 | 2.90  | 263.09 |
| .0015                          | 2.78  | 201.22 | 2.80  | 209.66 | 2.84  | 219.87 | 2.87  | 229.60 | 2.91  | 240.42 | 2.94  | 250.72 | 2.96  | 260.42 | 3.00  | 272.16 |
| .0016                          | 2.87  | 207.73 | 2.89  | 216.40 | 2.93  | 226.84 | 2.96  | 236.80 | 3.00  | 247.86 | 3.03  | 258.40 | 3.06  | 269.22 | 3.10  | 281.23 |
| .0017                          | 2.97  | 214.97 | 2.99  | 223.89 | 3.03  | 234.58 | 3.07  | 245.60 | 3.11  | 256.95 | 3.14  | 267.78 | 3.17  | 278.90 | 3.21  | 291.21 |
| .0018                          | 3.04  | 220.04 | 3.07  | 229.88 | 3.11  | 240.78 | 3.15  | 252.00 | 3.19  | 263.56 | 3.22  | 274.60 | 3.25  | 285.93 | 3.29  | 298.47 |
| .0019                          | 3.12  | 225.83 | 3.16  | 236.62 | 3.20  | 247.74 | 3.23  | 258.40 | 3.27  | 270.17 | 3.30  | 281.42 | 3.34  | 293.85 | 3.38  | 306.63 |
| .0020                          | 3.20  | 231.62 | 3.24  | 242.61 | 3.28  | 253.94 | 3.32  | 265.60 | 3.36  | 277.60 | 3.39  | 289.10 | 3.43  | 301.77 | 3.47  | 314.80 |

# Appendix 14B

# Tables for Computing Culvert Discharge

**Appendix 14B** Tables for computing culvert discharge,  $Q = Ca\sqrt{2gh}$  and minimum surcharge  $h_1$

where:

Q = flow rate (ft<sup>3</sup>/s)

g = gravitational constant = 32.2 ft/s<sup>2</sup>

a = pipe cross section (ft<sup>2</sup>)

h = head on pipe centerline (ft)

**Table A** Values of  $a\sqrt{2gh}$  for circular pipes flowing full

| h<br>(ft) | Diameter of pipe - inches |       |       |       |        |        |        |        |
|-----------|---------------------------|-------|-------|-------|--------|--------|--------|--------|
|           | 12                        | 18    | 24    | 30    | 36     | 42     | 48     | 60     |
| 0.1       | 2.0                       | 4.48  | 7.96  | 12.44 | 17.91  | 24.38  | 31.84  | 49.75  |
| 0.2       | 2.8                       | 6.33  | 11.26 | 17.60 | 25.34  | 34.49  | 45.05  | 70.39  |
| 0.3       | 3.4                       | 7.77  | 13.81 | 21.58 | 31.07  | 42.28  | 55.23  | 86.30  |
| 0.4       | 4.0                       | 8.96  | 15.93 | 24.88 | 35.83  | 48.77  | 63.70  | 99.53  |
| 0.5       | 4.4                       | 10.00 | 17.82 | 27.83 | 40.08  | 54.55  | 71.25  | 111.33 |
| 0.6       | 4.9                       | 10.98 | 19.53 | 30.51 | 43.94  | 59.80  | 78.11  | 122.05 |
| 0.7       | 5.3                       | 11.86 | 21.09 | 32.95 | 47.45  | 64.59  | 84.36  | 131.81 |
| 0.8       | 5.6                       | 12.67 | 22.53 | 35.20 | 50.61  | 68.98  | 90.10  | 140.78 |
| 0.9       | 6.0                       | 13.45 | 22.91 | 37.36 | 53.80  | 73.23  | 95.64  | 149.44 |
| 1.0       | 6.3                       | 14.17 | 25.20 | 39.37 | 56.69  | 77.16  | 100.78 | 157.47 |
| 1.5       | 7.7                       | 17.36 | 30.87 | 48.23 | 69.45  | 94.53  | 123.46 | 192.91 |
| 2.0       | 8.9                       | 20.04 | 35.63 | 53.67 | 80.16  | 109.10 | 142.50 | 222.66 |
| 2.5       | 10.0                      | 22.41 | 39.84 | 62.24 | 89.63  | 121.99 | 159.34 | 248.97 |
| 3.0       | 10.9                      | 24.55 | 43.65 | 68.19 | 98.20  | 133.65 | 174.55 | 272.75 |
| 3.5       | 11.8                      | 26.51 | 47.15 | 73.66 | 106.07 | 144.36 | 188.55 | 294.62 |
| 4.0       | 12.6                      | 28.34 | 50.40 | 78.74 | 113.39 | 154.32 | 201.56 | 314.95 |
| 4.5       | 13.4                      | 30.06 | 53.45 | 83.50 | 120.24 | 163.65 | 213.75 | 333.99 |
| 5.0       | 14.1                      | 31.69 | 56.35 | 88.03 | 126.77 | 172.53 | 225.35 | 352.11 |

Values of coefficient of discharge C (King's Handbook of Hydraulics)  
(Tables B, C-1, and C-2)

**Table B** Corrugated metal pipe

$$C = \left( 1 + .033d^{0.6} + \frac{0.0845}{d^{1.2}} \right)^{-\frac{1}{2}}$$

| Diameter<br>(inches) | Length in feet |      |      |      |      |
|----------------------|----------------|------|------|------|------|
|                      | 60             | 80   | 100  | 120  | 140  |
| 12                   | 0.36           | 0.32 | 0.29 | 0.27 | 0.25 |
| 18                   | 0.44           | 0.40 | 0.36 | 0.33 | 0.31 |
| 24                   | 0.50           | 0.45 | 0.41 | 0.38 | 0.36 |
| 30                   | 0.54           | 0.49 | 0.46 | 0.43 | 0.40 |
| 36                   | 0.58           | 0.53 | 0.49 | 0.46 | 0.44 |
| 42                   | 0.60           | 0.56 | 0.52 | 0.49 | 0.46 |
| 48                   | 0.62           | 0.58 | 0.54 | 0.51 | 0.49 |
| 60                   | 0.66           | 0.61 | 0.58 | 0.55 | 0.53 |

**Table C-1** Concrete pipe-beveled lip

$$C = \left( 1.1 + \frac{0.02056}{d^{1.2}} \right)^{-\frac{1}{2}}$$

| Diameter<br>(inches) | Length in feet |      |      |      |      |
|----------------------|----------------|------|------|------|------|
|                      | 60             | 80   | 100  | 120  | 140  |
| 12                   | 0.61           | 0.56 | 0.52 | 0.49 | 0.46 |
| 18                   | 0.70           | 0.65 | 0.61 | 0.58 | 0.55 |
| 24                   | 0.75           | 0.71 | 0.67 | 0.64 | 0.61 |
| 30                   | 0.79           | 0.75 | 0.71 | 0.68 | 0.66 |
| 36                   | 0.81           | 0.78 | 0.74 | 0.71 | 0.69 |
| 42                   | 0.83           | 0.80 | 0.77 | 0.74 | 0.72 |
| 48                   | 0.85           | 0.82 | 0.79 | 0.77 | 0.75 |
| 60                   | 0.87           | 0.84 | 0.82 | 0.80 | 0.78 |

**Appendix 14B** Tables for computing culvert discharge— $Q = Ca\sqrt{2gh}$  and minimum surcharge  $h_1$  (Continued)**Table C-2** Concrete pipe, square cornered entrance
$$C = \left( 1 + 0.56d^{0.5} + \frac{0.02056}{d^{1.2}} \right)^{-\frac{1}{2}}$$

| Diameter<br>(inches) | ----- Length in feet ----- |      |      |      |      |
|----------------------|----------------------------|------|------|------|------|
|                      | 60                         | 80   | 100  | 120  | 140  |
| 12                   | 0.59                       | 0.54 | 0.51 | 0.48 | 0.45 |
| 18                   | 0.65                       | 0.61 | 0.58 | 0.55 | 0.53 |
| 24                   | 0.69                       | 0.65 | 0.62 | 0.60 | 0.58 |
| 30                   | 0.71                       | 0.68 | 0.65 | 0.63 | 0.61 |
| 36                   | 0.72                       | 0.69 | 0.67 | 0.65 | 0.63 |
| 42                   | 0.72                       | 0.70 | 0.68 | 0.66 | 0.65 |
| 48                   | 0.72                       | 0.70 | 0.69 | 0.67 | 0.66 |
| 60                   | 0.72                       | 0.71 | 0.70 | 0.68 | 0.67 |

**Table D** Pipe size vs. area

| Diameter<br>(inches) | Area - a<br>ft <sup>2</sup> |
|----------------------|-----------------------------|
| 6                    | 0.196                       |
| 8                    | 0.349                       |
| 12                   | 0.785                       |
| 18                   | 1.767                       |
| 24                   | 3.142                       |
| 30                   | 4.909                       |
| <u>36</u>            | <u>7.069</u>                |
| 42                   | 9.621                       |
| 48                   | 12.566                      |
| 60                   | 19.635                      |

**Table E** Minimum surcharge ( $h_1$ ) for corrugated metal pipe (ft)

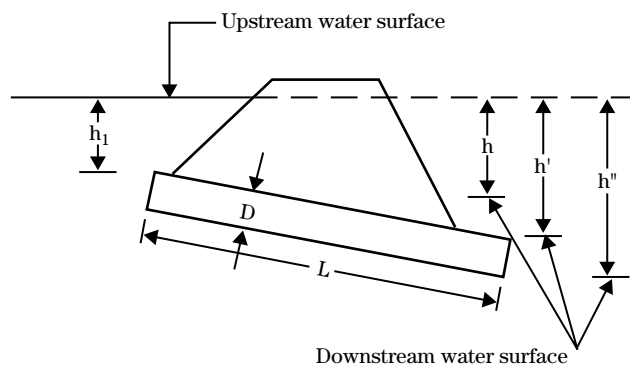
| $h_1$ | 0.0   | 0.1   | 0.2   | 0.3   | 0.4   | 0.5   | 0.6   | 0.7   | 0.8   | 0.9   |
|-------|-------|-------|-------|-------|-------|-------|-------|-------|-------|-------|
| 0.0   | vel.  | 2.13  | 3.01  | 3.69  | 4.27  | 4.76  | 5.22  | 5.64  | 6.03  | 6.40  |
| 1.0   | 6.74  | 7.07  | 7.39  | 7.69  | 7.98  | 8.26  | 8.59  | 8.79  | 9.04  | 9.29  |
| 2.0   | 9.53  | 9.77  | 10.00 | 10.22 | 10.44 | 10.65 | 10.87 | 11.08 | 11.28 | 11.48 |
| 3.0   | 11.67 | 11.87 | 12.06 | 12.25 | 12.43 | 12.61 | 12.79 | 12.96 | 13.14 | 13.31 |
| 4.0   | 13.48 | 13.65 |       |       |       |       |       |       |       |       |

 $h_1$  in feet =  $0.022 v^2$ **Table F** Minimum surcharge ( $h_1$ ) for concrete pipe (ft)

| $h_1$ | 0.0   | 0.1   | 0.2   | 0.3   | 0.4   | 0.5   | 0.6   | 0.7   | 0.8   | 0.9   |
|-------|-------|-------|-------|-------|-------|-------|-------|-------|-------|-------|
| 0.0   | vel.  | 2.42  | 3.41  | 4.18  | 4.85  | 5.42  | 5.94  | 6.34  | 6.86  | 7.27  |
| 1.0   | 7.67  | 8.04  | 8.40  | 8.76  | 9.08  | 9.39  | 9.70  | 10.00 | 10.29 | 10.57 |
| 2.0   | 10.87 | 11.11 | 11.38 | 11.63 | 11.88 | 12.12 | 12.37 | 12.58 | 12.84 | 13.06 |
| 3.0   | 13.28 | 13.50 | 13.72 | 13.94 | 14.14 | 14.34 | 14.55 | 14.75 | 14.95 | 15.15 |
| 4.0   | 15.34 | 15.53 | 15.72 | 15.88 | 16.09 | 16.26 | 16.45 | 16.63 |       |       |

 $h_1$  in feet =  $0.017 v^2$

**Appendix 14B** Tables for computing culvert discharge;  $Q = Ca\sqrt{2gh}$  and minimum surcharge  $h_1$  (Continued)



$h_1$  = Surcharge at culvert entrance.  
 $0.022 v^2$  for C.M.P.  
 $0.017 v^2$  for concrete pipe  
 For free outlet, use  $h'$  for  $h''$ ;  
 $h'$  may be approximated as  $h''$   
 less an assumed vertical diameter.

**Example:**

A 60-foot-long CMP culvert that has a submerged outlet must carry discharge of 44 cubic feet per second. The difference ( $h$ ) water surface upstream and downstream of the pipe is 2 feet.

**Solution:**

Try a 36-inch diameter. Enter table A at the 2.0 foot head. Under the 36-inch column, you will find that

$$a\sqrt{2gh} = 80.16.$$

In table B in the 36-inch diameter and 60-foot length,  $C = 0.58$ , so  $80.16 \times 0.58 = 46.5 \text{ ft}^3/\text{s}$ .

Therefore, the 36-inch diameter pipe has sufficient capacity.

In table D, an area of 36 inches = 7.069 square feet, therefore velocity is  $44 \div 7.069 = 6.22 \text{ ft/s}$ .

By interpolation, enter table E at velocity 6.22 ft/s. Find minimum surcharge  $h_1$  of 0.85 foot. The top of the 36-inch CMP must be set 0.85 foot below the water surface or hydraulic gradeline upstream of the culvert.



The proper operation of a viable, permanent irrigated agriculture system, especially when using saline water, requires periodic information on the levels and distributions of soil salinity within the crop root zones. The salt concentration within the root zone must be kept within tolerable levels. Direct monitoring of root zone salinity is recommended to evaluate the effectiveness of various management programs. The shape of the soil's salinity-depth relation and information on water table depth provide information of the direction of net flux and hence of the adequacy of the irrigation/drainage system.

Changes in soil salinity are determined from periodic measurements. Several in-field salinity monitoring tools have been developed to replace the cumbersome laboratory processes as shown in figure 14-26 and described in section 650.1421 (f). Mobilized, instrumental systems that measure field salinity have evolved over the last decade. One system of field salinity measurement ( $EC_a$ ) is based solely on the use of four-electrode units to measure  $EC_a$ . The other

system uses an electromagnetic induction sensor, either solely or together with four electrode units.

**The Mobile Four-electrode Sensing System**—In this system (fig. 1), the electrodes are combined into the "heels" of tillage shanks and mounted on a hydraulically controlled toolbar attached to a tractor via a conventional three-point hitch. The electrodes run at a depth of about 10 cm in the soil as the tractor moves across the field at a speed of 1.0 to 2.5 meters per second. A Global Positioning System (GPS) antenna is positioned above the tractor cab and used to determine the spatial position of each sensor reading (the unit now being used is capable of real time accuracies of less than one meter). The  $EC_a$  and the GPS signals are sensed at adjustable frequencies (as often as every second) and logged into memory for later analysis of salinity condition and spatial relations. The four-electrode conductivity meter, the GPS receiver, their respective power supplies, and their data loggers are contained in the water-tight, stainless steel box mounted behind the toolbar shown in figure 1. The

---

**Figure 1** Mobile four-electrode sensing system



tractor operator is provided a remote monitor (not shown) displaying time,  $EC_a$  reading, and logging status. Analysis of the spatial data is carried out at the field's edge in a mobile office equipped with a computer workstation and soil-salinity testing facilities.

**The Combination, Mobile Electromagnetic-Induction/Four-Electrode Sensing System**—This system involves a Geonics, EM-38 instrument mounted in front of the transport vehicle (a modified spot-spray tractor) within a vinyl ester pipe as well as two sets of four-electrode arrays (having 1 and 2 meter spacings between current electrodes, respectively) mounted under the vehicle, as shown in figure 2. The EM-38 mounting tube fastens to the vehicle by sliding over a short section of steel tubing. The EM-38 is secured within the vinyl ester tube by means of slotted hardwood bulkheads. All hardware within the tube is non-metallic. The tube may be removed and placed in a

cradle at the back of the vehicle for long-distance travel. The EM-tube can be rotated so that EM-38 readings are made in horizontal ( $EM_H$ ) or vertical ( $EM_V$ ) configurations. This is done with a small gear-head DC motor and belt that operates via a non-slip cable applied to the tube. The tube and rotator are mounted on a hydraulic apparatus that elevates the EM-38 sensor sequentially to various heights above ground and translates it sequentially in the horizontal direction. This allows both  $EM_H$  and  $EM_V$  measurements to be made sequentially at various heights above the furrow and the seedbed. The changes in height and orientation of the EM-38 sensor are undertaken to alter the depth and distribution of the EM signal in the soil and, thus, to permit the determination of the salinity distribution in the root zone in two dimensions. The four-electrode arrays are mounted on a hydraulically operated, scissor-action mechanism.

**Figure 2** Combination, mobile electromagnetic-induction/four-electrode sensing system





This mechanism includes a sensor and control mechanism to insert the probes sequentially to selected depths in the soil and to correspondingly measure  $EC_a$  at 1- and 2-meter array spacings in both the furrow and seedbed. In figure 2, the EM-sensor and four-electrode arrays are in the up, or travel, position.

An automated control system was developed to carry out the sequence of 52 operations involved in the full range of possible sequential EM-38 and four-electrode measurements. The control system is based upon switches and relay logic with auxiliary electronic timing. The system is operated via an interface control panel with enable buttons for activating EM and four-electrode sensor measurements and a 6-position selection switch for positioning the sensors over (and at various heights above for the EM sensor) the furrow and seedbed. When the EM button is enabled, the EM sensor is rotated to the vertical ( $EM_v$ ) configuration and the carriage moves both the EM and four-electrode sensors to the selected position (e.g., above the furrow or seedbed). The EM start button then initiates the following automated sequence:

1. The  $EM_v$  reading is made and a selectable delay (usually 1.5 seconds) is provided for data logging.
2. The EM-38 sensor is rotated to the horizontal position.
3. The  $EM_H$  reading is made and logged after the selected delay interval.
4. The EM-38 sensor is rotated back to the vertical position.

This sequence is repeated for each Y-Z position selected. Depressing the four-electrode start button initiates the following automated sequence:

1. The scissors apparatus probes to the first depth limit.
2.  $EC_a$  is measured at the 1 meter array spacing.
3. A delay is provided for data logging at the 1 meter spacing.
4. The meter/logger is switched to the 2 meter array.
5.  $EC_a$  is read after a delay at the 2 meter array spacing.
6. A delay is provided for data logging at the 2 meter spacing.
7. The probes are inserted to the next depth limit (up to 5 depths are possible).
8. Steps 2 through 6 are repeated.

After completion of the last logging, the scissors apparatus lifts the electrodes from the soil and stores them in the travel position. A small printed circuit board provides the necessary time delay functions. The mobile unit then moves to the next measurement site (stop). All measurements at each site can be made in about 30 to 45 seconds.

Reference: J. D. Rhodes. Management of Saline/Sodic Soils. USDA Soil Conservation Service and U.S. Salinity Laboratory, Training Note 4, Practices to Control Salinity in Irrigated Soils.



## (1) Auger-hole method

The auger-hole method is the simplest and most accurate way to determine soil permeability (fig. 1). The measurements obtained using this method are a combination of vertical and lateral conductivity, however, under most conditions, the measurements represent the lateral value. The most limiting obstacle for using this method is the need for a water table within that part of the soil profile to be evaluated. This limitation requires more intensive planning. Tests must be made when a water table is available during the wet season. Obtaining accurate readings using this method requires a thorough knowledge of the procedure.

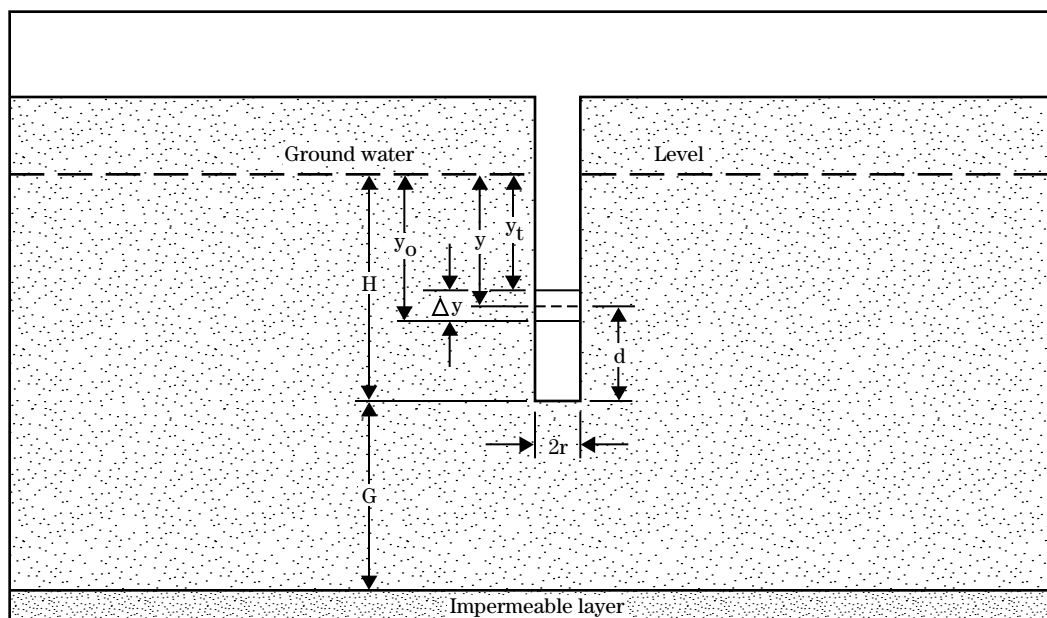
The principle of the auger-hole method is simple. A hole is bored to a certain distance below the water table. This should be to a depth about 1 foot below the average depth of drains. The depth of water in the hole should be about 5 to 10 times the diameter of the hole. The water level is lowered by pumping or bailing, and the rate at which the ground water flows back into the hole is measured. The hydraulic conductivity can then be computed by a formula that relates the geometry of the hole to the rate at which the water flows into it.

*(i) Formulas for determination of hydraulic conductivity by auger-hole method*—Determination of the hydraulic conductivity by the auger-hole method is affected by the location of the barrier or impermeable layer.

A barrier or impermeable layer is defined as a less permeable stratum, continuous over a major portion of the area and of such thickness as to provide a positive deterrent to the downward movement of ground water. The hydraulic conductivity of the barrier must be less than 10 percent of that of the overlying material if it is to be considered as a barrier. For the case where the impermeable layer coincides with the bottom of the hole, a formula for determining the hydraulic conductivity (K) has been developed by Van Bavel and Kirkham (1948).

$$K = \left( \frac{2220r}{SH} \right) \left( \frac{\Delta y}{\Delta t} \right) \quad [1]$$

**Figure 1** Symbols for auger-hole method of measuring hydraulic conductivity



where:

- S = a function dependent on the geometry of the hole, the static depth of water, and the average depth of water during the test  
 K = hydraulic conductivity (in/hr)  
 H = depth of hole below the ground water table (in)  
 r = radius of auger hole (in)  
 y = distance between ground water level and the average level of water in the hole (in) for the time interval t (s)  
 $\Delta y$  = rise of water (in) in auger hole during  $\Delta t$   
 t = time interval (s)  
 G = depth of the impermeable layer below the bottom of the hole (in). Impermeable layer is defined as a layer that has the permeability of no more than a tenth of the permeability of the layers above.  
 d = average depth of water in auger hole during test (in)

A sample form for use in recording field observations and making the necessary computations is illustrated in figure 2. This includes a chart for determining the geometric function S for use in the formula for calculation of the hydraulic conductivity.

The more usual situation is where the bottom of the auger hole is some distance above the barrier. Formulas for computing the hydraulic conductivity in homogeneous soils by the auger-hole method have been developed for both cases (Ernst, 1950). These formulas (2 and 3) are converted to English units of measurement.

For the case where the impermeable layer is at the bottom of the auger-hole,  $G = 0$ :

$$K = \frac{15,000r^2}{(H + 10r) \left( 2 - \frac{y}{H} \right) y} \frac{\Delta y}{\Delta t} \quad [2]$$

For the case where the impermeable layer is at a depth  $\geq 0.5H$  below the bottom of the auger hole:

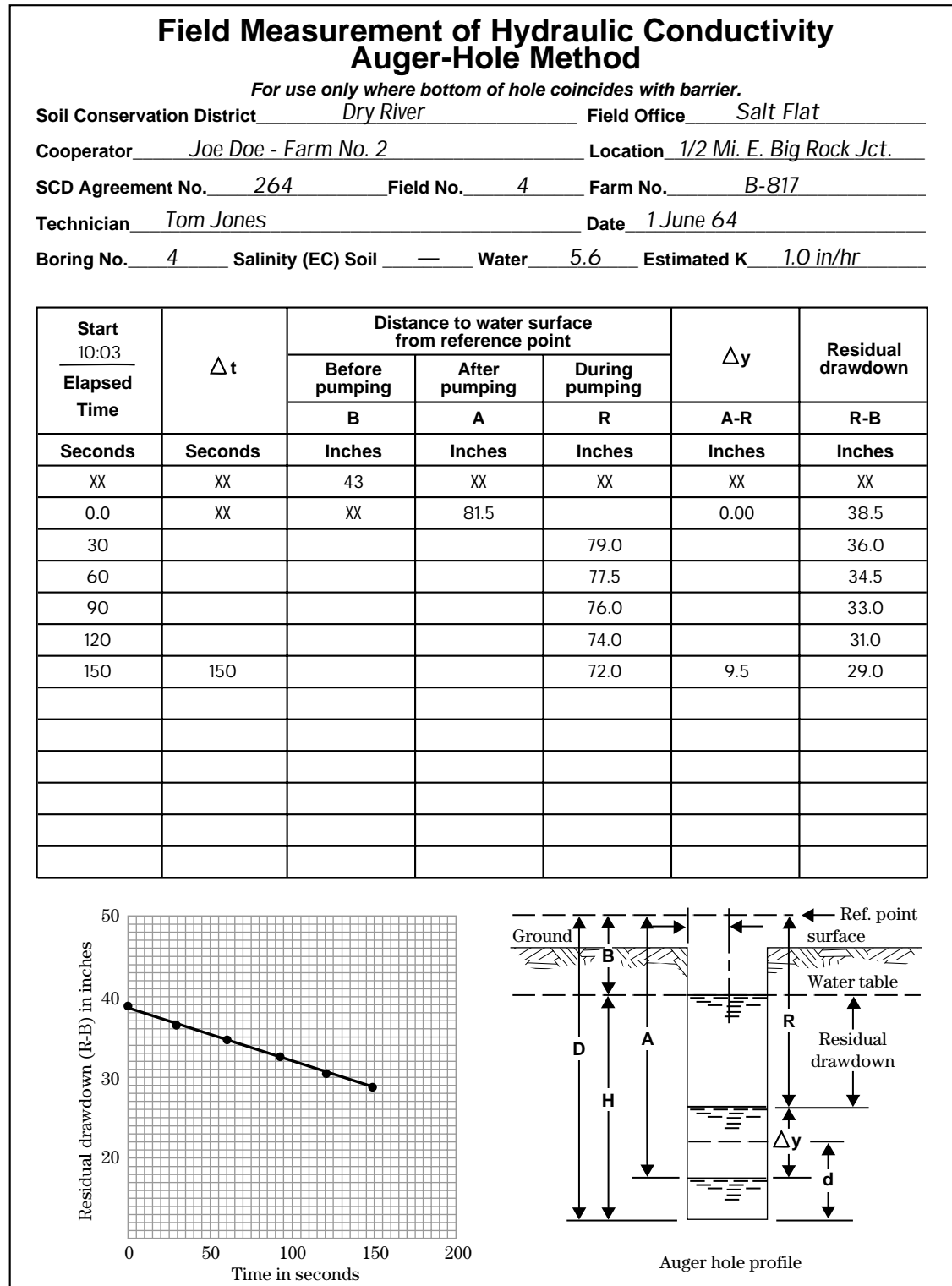
$$K = \frac{16,667r^2}{(H + 20r) \left( 2 - \frac{y}{H} \right) y} \frac{\Delta y}{\Delta t} \quad [3]$$

The following conditions should be met to obtain acceptable accuracy from use of the auger-hole method:

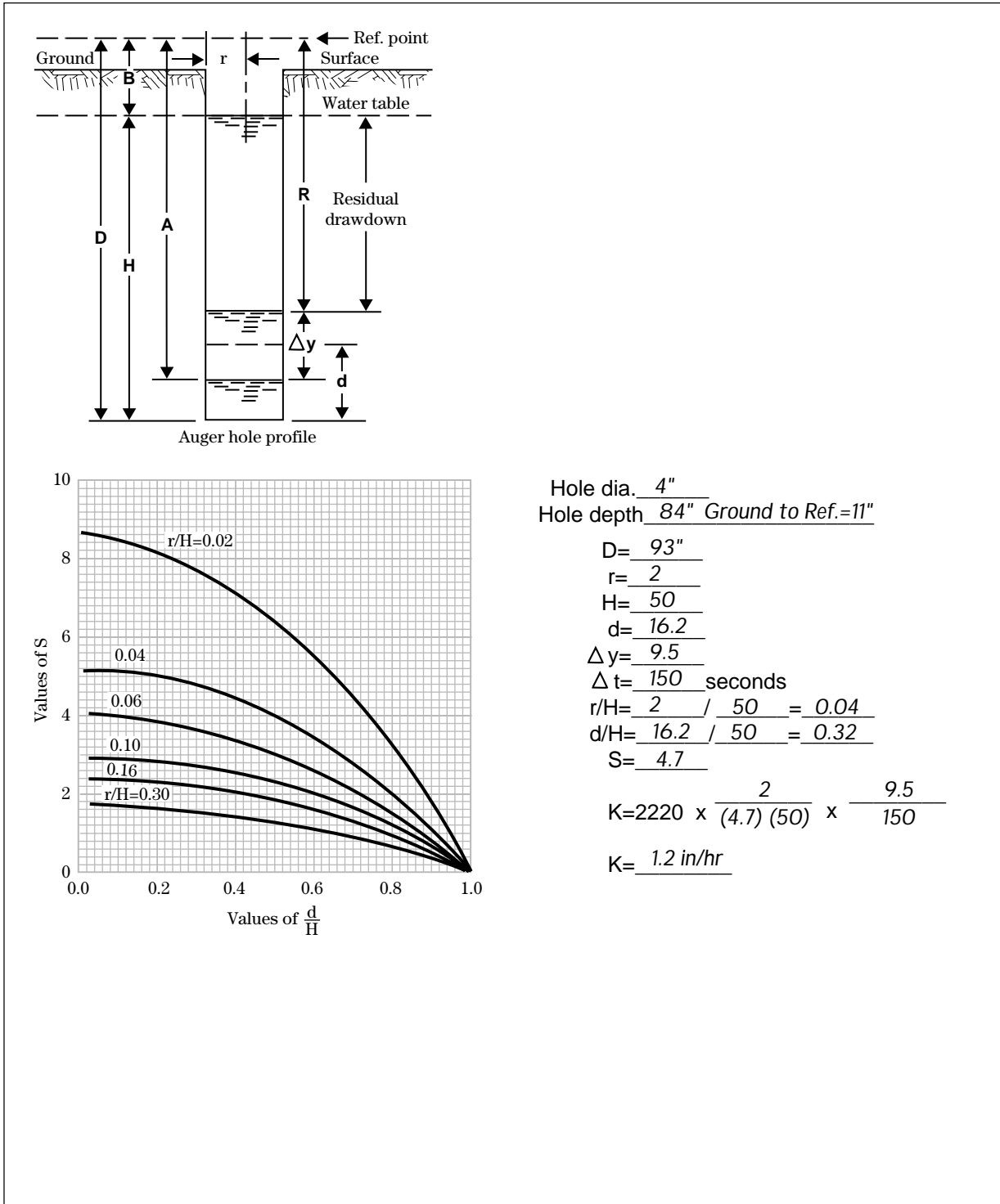
- $2r > 2 \frac{1}{2}$  and  $< 5 \frac{1}{2}$  inches
- $H > 10$  and  $< 80$  inches
- $y > 0.2 H$
- $G > H$
- $y < 1/4 y_o$

Charts have been prepared for solution of equation 3 for auger-holes of  $r = 1 \frac{1}{2}$  and 2 inches. For the case where the impermeable layer is at the bottom of the auger hole, the hydraulic conductivity may be determined from these charts by multiplying the value obtained by a conversion factor f as indicated on figure 3.

**Figure 2a** Auger-hole method of measuring hydraulic conductivity—sheet 1 of 2

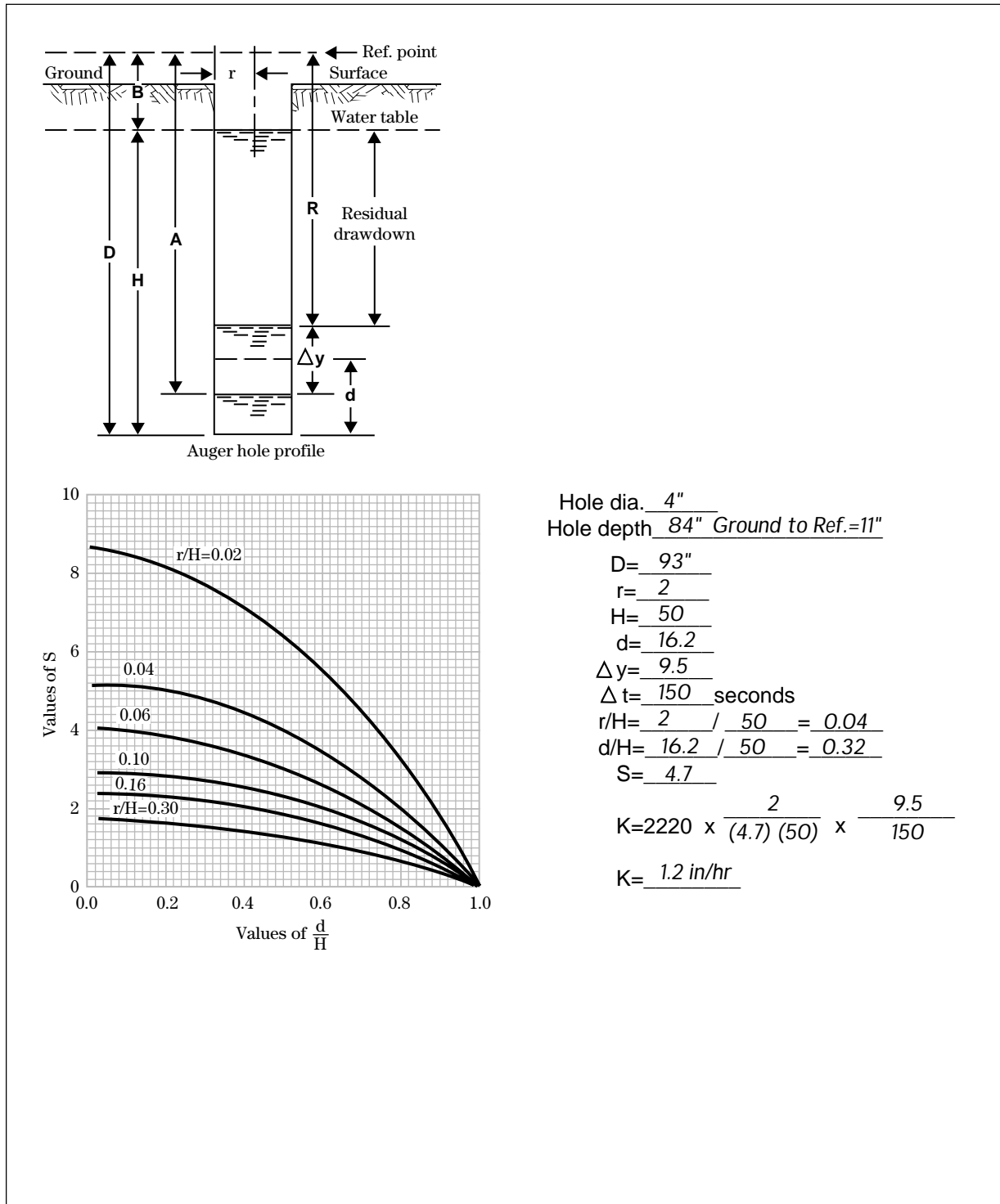


**Figure 2a** Auger-hole method of measuring hydraulic conductivity—sheet 2 of 2



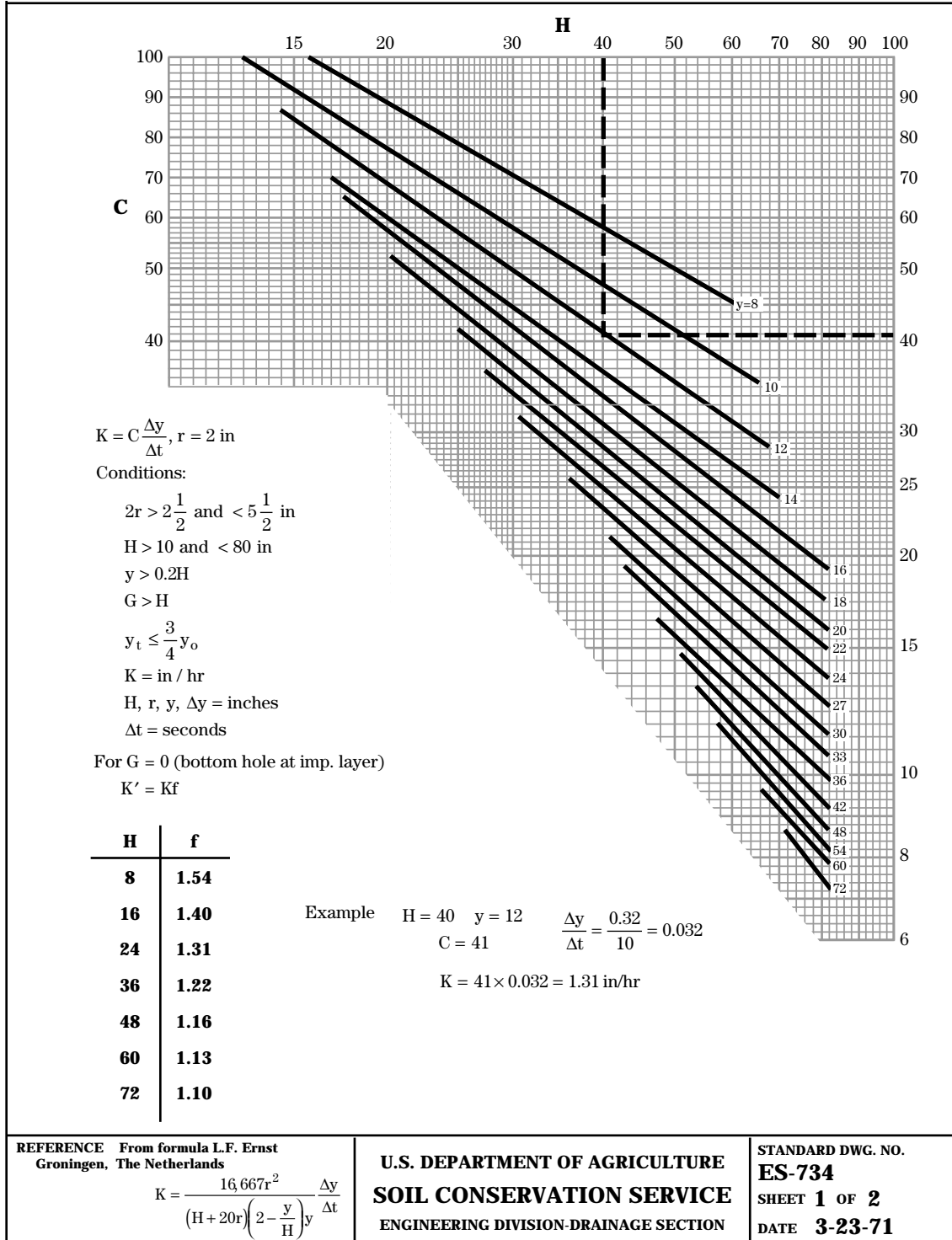


**Figure 2b** Auger-hole method of measuring hydraulic conductivity—sheet 2 of 2 (blank)

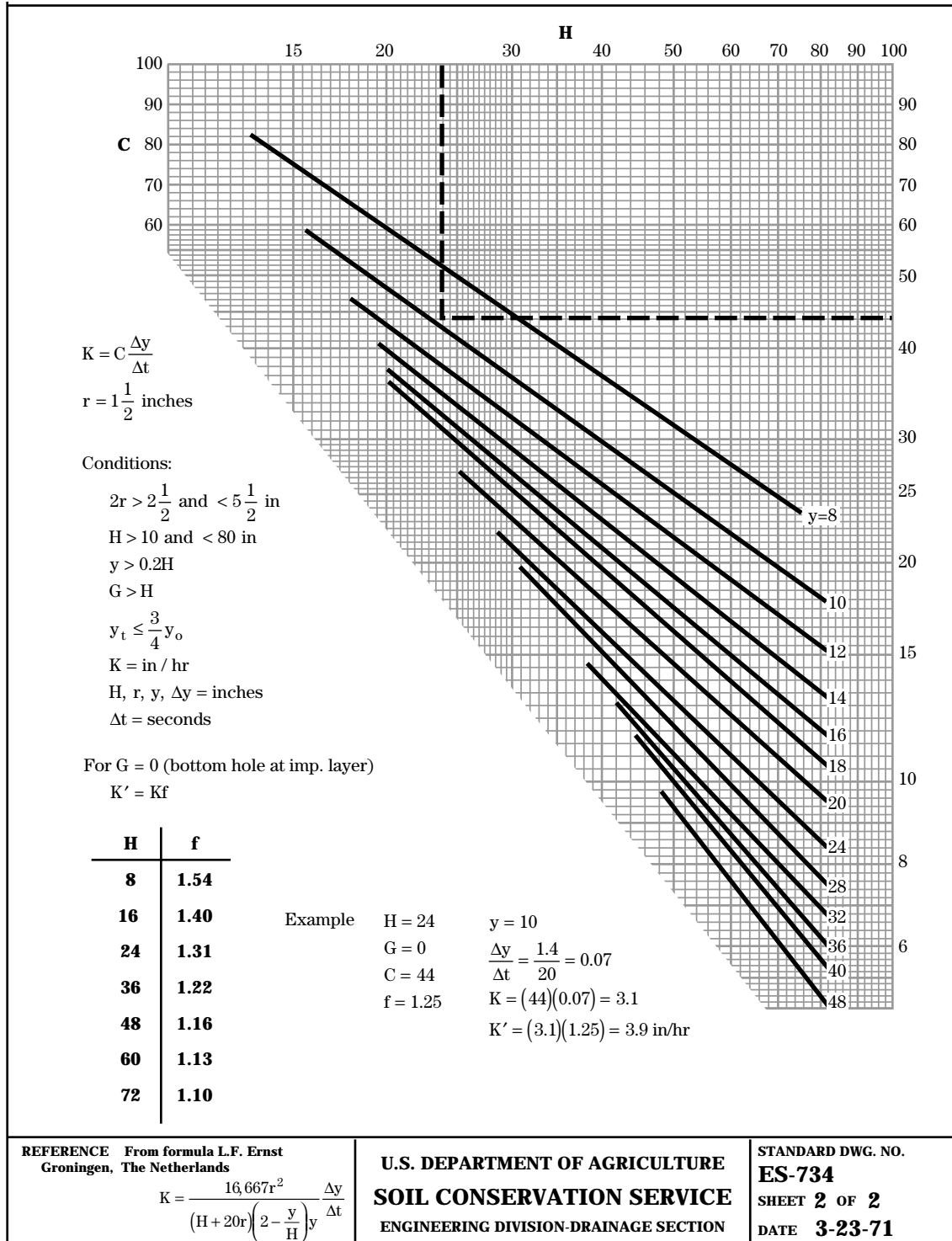




**Figure 3** Hydraulic conductivity—auger-hole method using the Ernst Formula



**Figure 3** Hydraulic conductivity—auger-hole method by Ernst Formula—continued



**(ii) Equipment for auger-hole method**—The following equipment is required to test hydraulic conductivity:

- suitable auger
- pump or bail bucket to remove water from the hole
- watch with a second hand
- device for measuring the depth of water in the hole as it rises during recharge
- well screen may be necessary for use in unstable soils

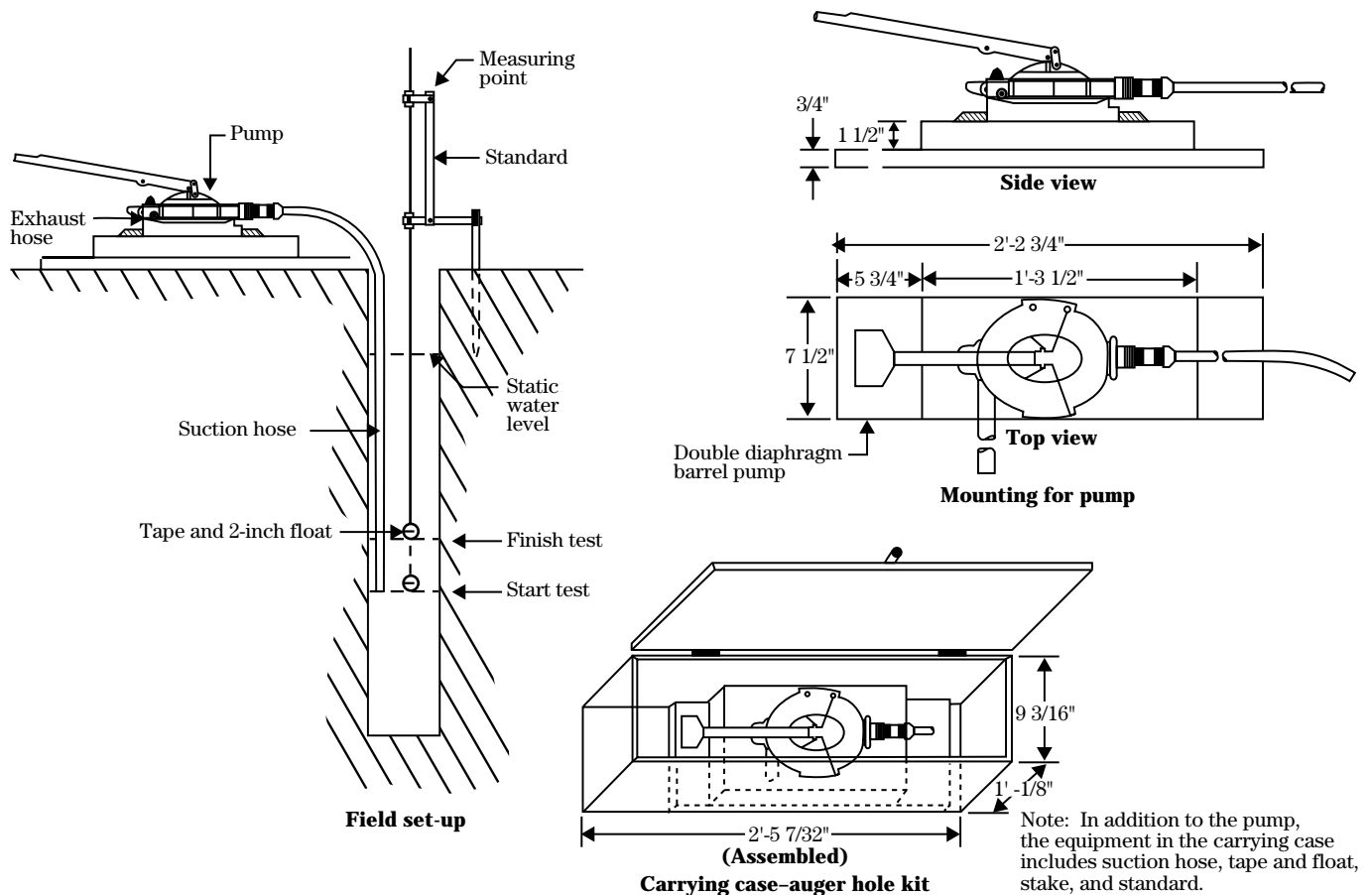
Many operators prefer a well made, light weight boat or stirrup pump that is easily disassembled for cleaning. A small, double diaphragm barrel pump has given good service. It can be mounted on a wooden frame for ease of handling and use.

For the depth measuring device, a light weight bamboo fishing rod marked in feet tenths and hundredths and that has a cork float works well. Other types of floats include a juice can with a standard soldered to one end to hold a light weight measuring rod.

A field kit for making the auger hole measurement of hydraulic conductivity is illustrated in figure 4. In addition to the items indicated in this figure, a watch and a soil auger are needed.

A perforated liner for the auger-hole is used in making the auger-hole measurement in fluid sands. This liner keeps the hole open and maintains the correct size. Several types of liners are used. Adequate slot openings or other perforations must be provided to allow free flow into the pipe.

**Figure 4** Equipment for auger-hole method of measuring hydraulic conductivity



The openings in the screen should not restrict flow appreciably. The head loss through the screen should be negligible, and the velocity of flow through the openings should be small (0.3 foot per second or less) to prevent movement of fines into the hole. These criteria generally are met if the area of openings is 5 percent or more of the total screen area.

The Bureau of Reclamation uses 4-inch downspouting with 60 1/8- by 1-inch slots per foot of length. This works well in a variety of soils. A screen from the Netherlands is made from a punched brass sheet 2 millimeters thick with holes averaging about 0.5 millimeter in diameter. It is rolled into a tube 8 centimeters in diameter by 1 meter long. This screen works well because the sheet is rolled so that the direction in which the holes are punched is outward and the holes are variable in size. It has been used in many troublesome soils, and no clogging or failure to keep fines out of the hole has been reported.

Good judgment is needed in determining how far to drawdown the water level in the auger hole for the test. A minimum drawdown is necessary to physically satisfy theoretical criteria (refer to conditions given in fig. 3). Generally, a larger drawdown is made for slowly permeable soils than that for more permeable soils. A small drawdown for holes in sloughing soils may reduce the amount of sloughing. To prevent picking up sand in the pump, pumping should stop when the water level is within a few inches of the bottom of the hole.

Measurement of the rate of recovery of water in the auger hole should be completed before a fourth of the total amount of drawdown is recovered. Four or five readings should be taken at uniform short time intervals, and a plot of the readings made to determine a uniform rate of recovery to use in the formula. Plotting of time in seconds against the residual drawdown in inches indicates those readings at the beginning and end of the test that should be discarded and the proper values of  $t$  and  $y$  to use.

*The following transient state procedure for determining drain spacing was developed by the U.S. Bureau of Reclamation. With permission from USBR the description and figures are reproduced from their Drainage Manual (USBR, 1993).*

## Transient flow method of drain spacing

In the 1950's, the Bureau of Reclamation developed a method for estimating drain spacing based on transient flow conditions that relates the behavior of the water table to time and drain spacing. The validity of this method is demonstrated by the close correlation between actual spacing and drawdown values, and the corresponding predicted values. Reclamation's method of determining drain spacing accounts for time, water quantity, geology, and soil characteristics pertinent to the irrigation of specific areas. Although this method was developed for use in a relatively flat area, laboratory research and field experience show the method is applicable for areas having slopes up to 10 percent.

## Background of the method

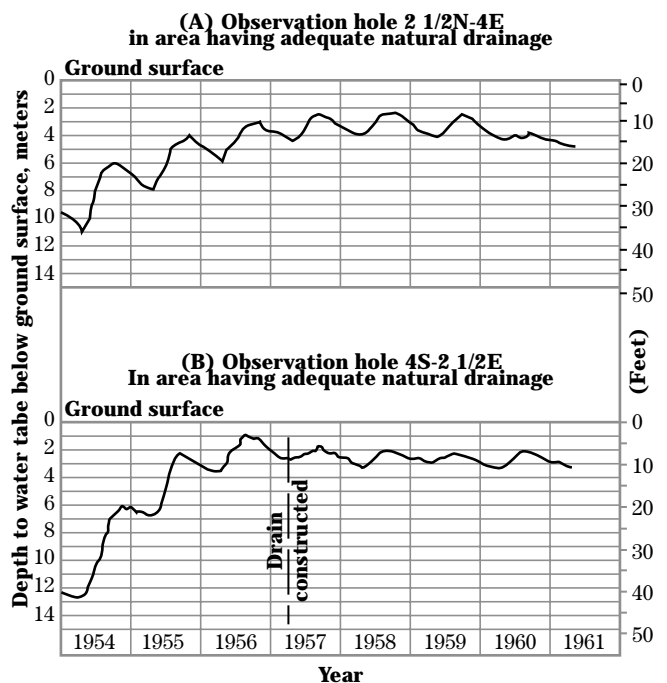
In general, water tables rise during the irrigation season in response to deep percolation water from irrigation applications. In arid areas, water levels reach their highest elevation after the last irrigation of the season. In areas of year-round cropping, maximum levels occur at the end of the peak period of irrigation. The water table recedes during the slack or nonirrigation period and starts rising again with the beginning of irrigation the following year. Nearly all shallow water tables exhibit this cyclic phenomenon on an annual basis. Shallow water table rises also occur after each recharge to the ground water from precipitation or irrigation. Lowering of the water table occurs between recharges.

If annual discharge from an area does not equal or exceed annual recharge, the general cyclic water table fluctuation trend will progress upward from year to year. Specifically, the maximum and minimum water levels both reach progressively higher levels each year.

When the annual discharge and recharge are about equal, the range of the cyclic annual water table fluctuation becomes reasonably constant. This condition is referred to as *dynamic equilibrium*.

Figure 1 shows two ground water hydrographs that indicate how the above conditions developed under irrigation in two specific areas. The hydrograph for (A) on this figure shows the upward cyclic trend and the stabilization of the cyclic fluctuation. Dynamic equilibrium occurred when the maximum water table elevation reached a point sufficiently below ground level to preclude the need for artificial drainage. The hydrograph for (B) shows a similar upward trend of the water table in another area. At this location, the maximum 1956 water table elevation and the continued upward trend indicated the imminence of a damaging water table condition in 1957. Therefore, a drain was constructed early in 1957, and its effect in producing dynamic equilibrium at a safe water table level is evident in the graph.

**Figure 1** Comparison between computed and measured drain spacings



Reclamation's method of determining drain spacing takes into account the transient regimen of the ground water recharge and discharge. The method gives spacings that produce dynamic equilibrium below a specified water table depth. The method also provides for consideration of specific soils, irrigation practices, crops, and climatic characteristics of the area under consideration.

## Data required

Figure 2 shows graphically the relationship between the the following dimensionless parameters based on the transient flow theory:

$$\frac{y}{y_o} \text{ versus } \frac{KDt}{SL^2} \text{ and } \frac{Z}{H} \text{ versus } \frac{KHt}{SL^2}$$

This figure shows relationships midpoint between drains for cases where drains are located above or on a barrier. Definitions of the various terms in the parameters are as follows:

**$y_o$  and  $H$** —The water table height above the drain, midway between the drains and at the beginning of each individual drain-out period, is represented by  $y_o$  and  $H$  for drains above and on the barrier, respectively. As used in the drain spacing calculations,  $y_o$  and  $H$  represent the water table height immediately after a water table buildup caused by deep percolation from precipitation or irrigation. Parameter terms  $y_o$  and  $H$  also represent the height of the water table at the beginning of each new drain-out period during the lowering process which occurs in the nonirrigation season. The maximum values of  $y_o$  and  $H$  are based on the requirements for an aerated root zone which, in turn, are based on the crops and climatic conditions of each specific area.

**$y$  and  $Z$** —The water table height above the drain, midway between the drains and at the end of each individual drainout period, is represented by  $y$  and  $Z$  for drains above and on the barrier, respectively. These terms represent the level to which the midpoint water table elevation falls during a drain-out period.

**Hydraulic conductivity,  $K$** —As used in this method,  $K$  represents the hydraulic conductivity in the flow zone between drains. Specifically,  $K$  is the weighted average hydraulic conductivity of all soils between the

maximum allowable water table height and barrier, the barrier being a slowly permeable zone. The mathematical solution of the transient flow theory assumes homogeneous, isotropic soils in this zone. Such assumptions rarely exist; however, the use of a weighted  $K$  value has given a good correlation between measured and computed values for drain spacing and water table fluctuations. The  $K$  value is obtained by averaging the results from in-place hydraulic conductivity tests at different locations in the area to be drained.

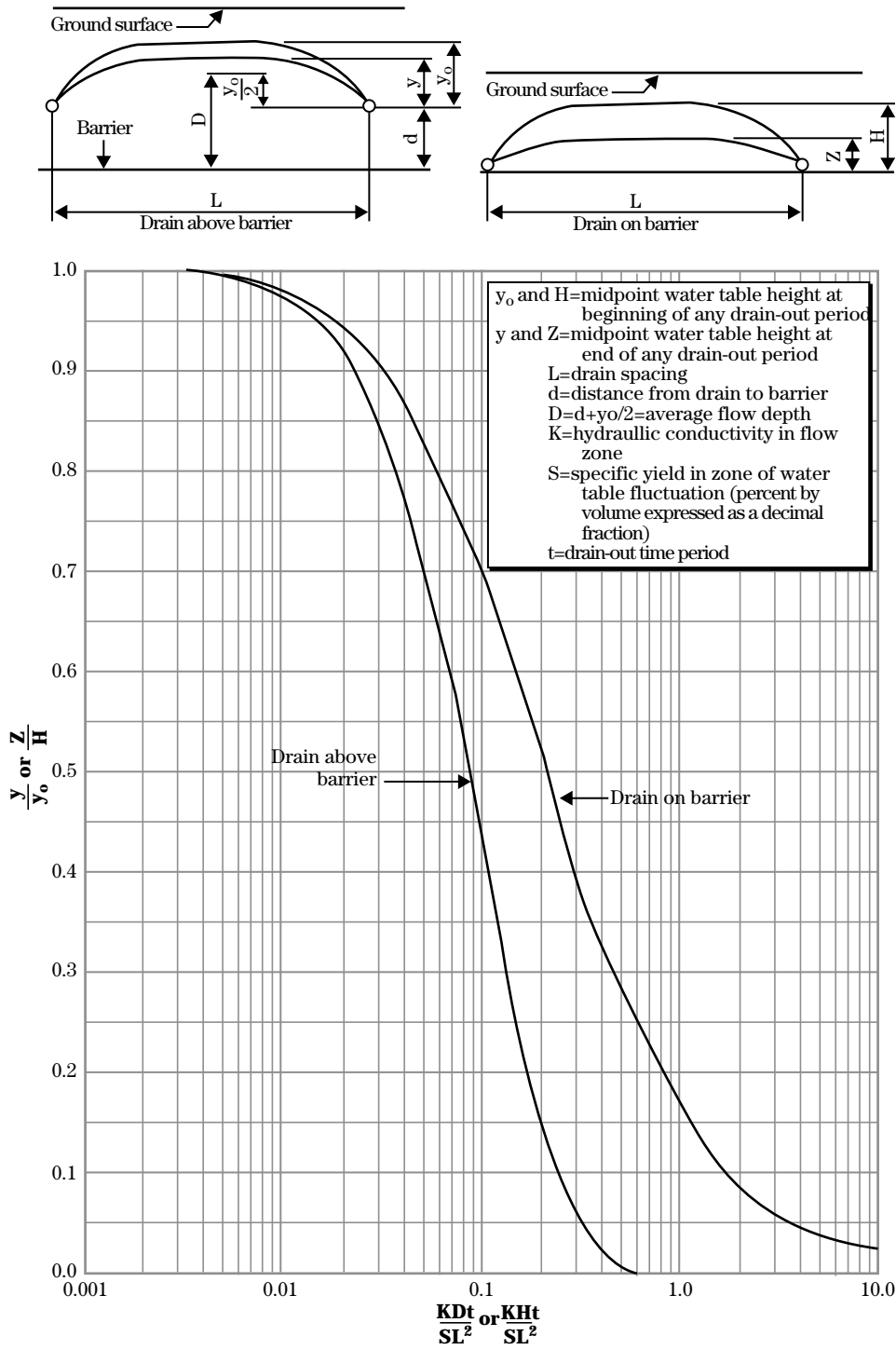
**Specific yield,  $S$** —The specific yield of a soil is the amount of ground water that will drain out of a saturated soil under the force of gravity.  $S$  is approximately the amount of water held by a soil material, on a percent-by-volume basis, between saturation and field capacity. Specific yield, therefore, relates the amount of fluctuation of the water table to the amount of ground water added to or drained from the system. On the basis of considerable data, a general relationship has been developed between hydraulic conductivity and specific yield. This relationship is shown on figure 3 and values from this figure can be used to estimate specific yield values used in the drain spacing calculations in most cases.

Because the fluctuation of the water table in a drained area takes place in the soil profile zone between the drains and the maximum allowable water table height, it is reasonable to assume that the average specific yield in this zone will adequately reflect water table fluctuations. The use of figure 3 to estimate the specific yield requires that the weighted average hydraulic conductivity in this zone be determined.

The specific yield value, when used in the parameters of figure 2, accounts for the amount of drainout associated with lowering the water table. To determine the buildup of the water table from each increment of recharge, the depth of each recharge should be divided by the specific yield.

**Time,  $t$** —This variable represents the drainout time between irrigations or at specified intervals during the nonirrigation season. In an irrigated area, the periods between irrigations have generally been established. The drain spacing calculations should separate the longer nonirrigation season into two or three approximately equal periods for accuracy in results.

**Figure 2** Curves showing relationship of parameters needed for drain spacing calculations using the transient-flow theory



**Flow depth, D**—The flow depth is the average flow depth transmitting water to the drain. As shown on figure 2, **D** is equal to the distance from the barrier to the drain, plus one-half the distance from the drain to the midpoint water table at the beginning of any drain-out period

$$D = d + \frac{y_o}{2}$$

The theoretical derivation for the case where drains are located above a barrier was based on the assumption that the distance from the drain to the barrier, *d*, is large compared with the midpoint water table height, *y<sub>o</sub>*. This poses a question regarding cases where the drains are above the barrier, but *d* is not large compared with *y<sub>o</sub>*. In verifying the applicability of figure 2, studies have indicated when

$$\frac{d}{y_o} \leq 0.10$$

the spacing computations should be made as if the drains were located on the barrier, and when

$$\frac{d}{y_o} \geq 0.80$$

the computations should be made as if the drains were located above the barrier. A family of curves could be drawn between the two curves shown on figure 2, or a computer program could be used to account for the values between 0.10 and 0.80.

$$\frac{d}{y_o}$$

The need for either of these refinements in the practical application of this method is not necessary.

**Drain spacing, L**—The drain spacing is the distance between parallel drains. However, this distance is not calculated directly using this method. Values of **L** must be assumed until a solution by trial and error results in annual water table buildup and decline that will offset each other within acceptable limits. This resulting condition is defined as a state of dynamic equilibrium.

**Figure 3** Curve showing general relationship between specific yield and hydraulic conductivity





## Convergence

When ground water flows toward a drain, the flow converges near the drain. This convergency causes a head loss in the ground water system and must be accounted for in the drain spacing computations. Figure 2 does not account for this convergency loss when the drain is above the barrier, and the drain spacing derived through the use of this curve is too large.

A method of accounting for convergence loss, developed by the Dutch engineer Hooghoudt, considers the loss in head required to overcome convergence in the primary spacing calculation. His method accounts for this head loss by using an equivalent depth,  $d'$ , to replace the measured depth,  $d$  in the calculation of

$$D = d + \frac{y_o}{2}$$

Hooghoudt's correction for convergence can be determined from the following equations:

$$d' = \frac{d}{1 + \frac{d}{L \left( 2.55 \ln \frac{d}{r - c} \right)}} \text{ for } 0 < \frac{d}{L} \leq 0.31$$

$$d' = \frac{L}{2.55 \left( \ln \frac{L}{r - 1.15} \right)} \text{ for } \frac{d}{L} > 0.31$$

where:

$d$  = distance from drain to barrier

$d'$  = Hooghoudt's equivalent distance from drain to barrier

$L$  = drain spacing

$r$  = outside radius of pipe plus gravel envelope

$$c = 3.55 - 1.6 \frac{d}{L} + 2 \left( \frac{d}{L} \right)^2$$

$\ln$  =  $\log_e$  = natural log

Curves have also been developed for determining  $d'$  and are shown on figures 4 and 5. These curves were developed for an effective drain radius,  $r$ , of 0.18 meter (0.6 foot) and should cover most pipe drain conditions. The effective drain radius is defined as the outside radius of the pipe plus the thickness of the gravel envelope. The use of the Hooghoudt method is also a trial and error process of assuming drain spacings. The  $d'$  value for the assumed spacing is obtained from figures 4 or 5 and is used to obtain the corrected average flow depth. This method of correcting for convergence has been found to be most appropriate for use with Reclamation's method of determining drain spacing and discharge rates.

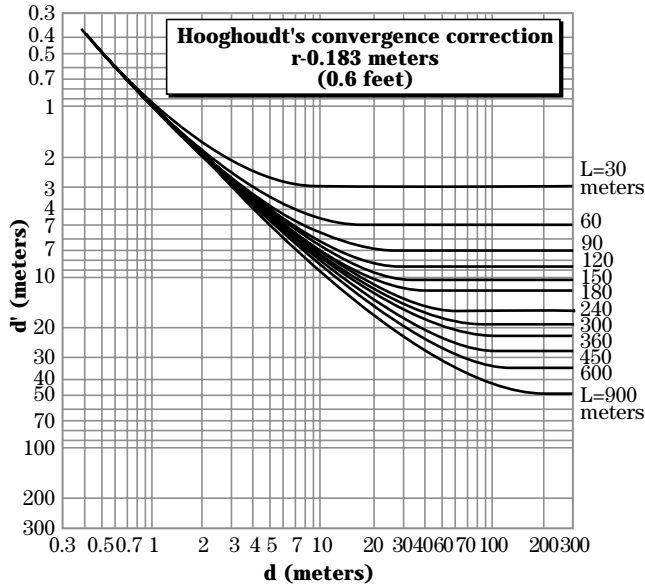
$$D' = d' + \frac{y_o}{2}$$

If the spacing that results from use of the equivalent depth  $d'$  is reduced by more than 5 percent from the spacing that results from use of the initial depth  $d$ , another iteration should be done using the initial depth  $d$  and the reduced spacing that resulted from the first  $d'$ .

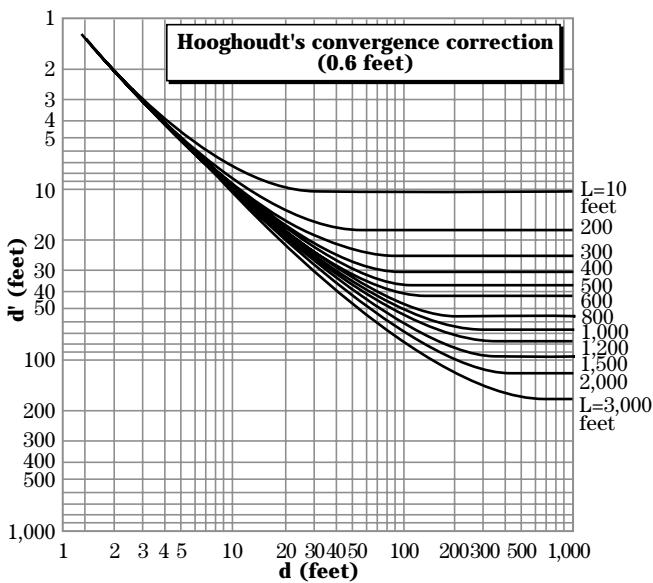
The curve of figure 2 for the drain on the barrier is based on a solution with the convergence accounted for in the initial mathematical model. Therefore, no correction for convergence is required when using this curve.

**Figure 4** Curves for determining Hooghoudt's convergence correction

a. metric units

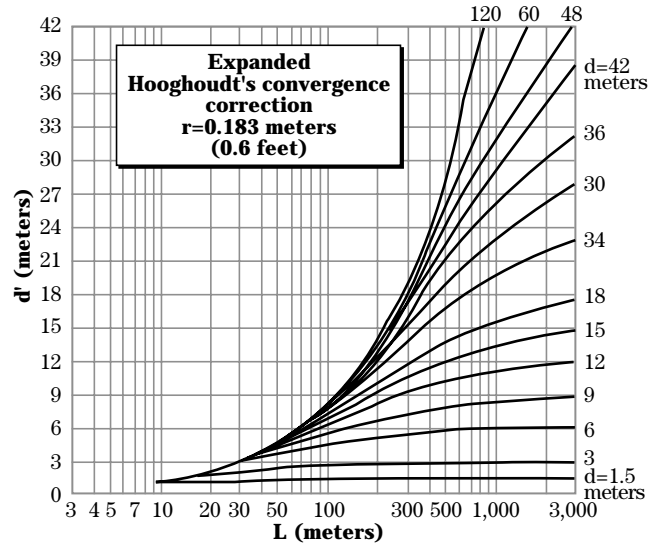


b. U.S. customary units

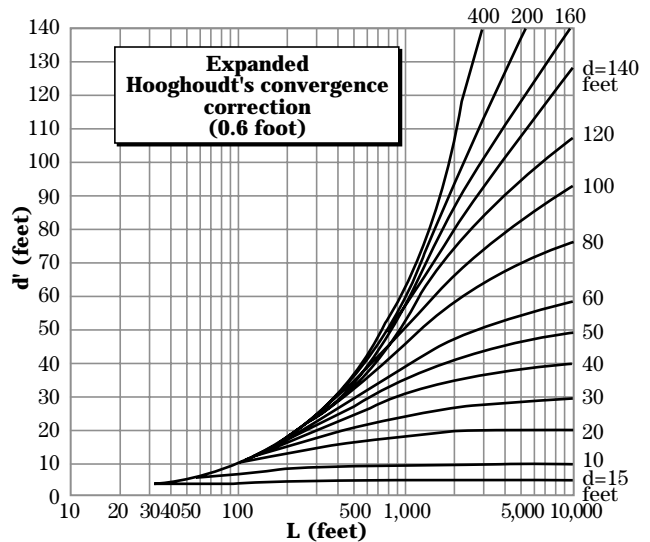


**Figure 5** Expanded curves for determining Hooghoudt's convergence correction

a. metric units



b. U.S. customary units



## Deep percolation and buildup

Deep percolation from any source causes a buildup in the water table. The methods of estimating drain spacing developed by the Bureau of Reclamation require that deep percolation and buildup in the water table from each source of recharge (rainfall, snow-melt, or irrigation application) be known or estimated and accounted for in the drain spacing calculations.

When a drainage problem exists on an operating project and drains are being planned, the buildup in the water table caused by irrigation applications can best be determined by field measurements. The water table depth should be measured at several locations in the area to be drained on the day before and on the day after several irrigation applications. The average buildup shown by these two measurements should be used in the spacing computations. These measurements obviate the need for theoretical estimates on the amount of deep percolation, and relate the buildup to the actual irrigation operations of the area to be drained.

In the planning stage of new projects or on operating projects where the measured buildup is not available, the amount of expected deep percolation must be estimated from each irrigation application. The buildup is computed by dividing the amount of deep percolation by the specific yield of the material in the zone where the water table is expected to fluctuate. Table 1 shows deep percolation as a percentage of the irrigation net input of water into the soil to be considered. These percentages are given on the basis of various soil textures and on infiltration rates of the upper root zone soils. These values should be used only for preliminary planning. More detailed investigations of deep percolation are required for project designs.

The following examples show how to use table 1 to obtain deep percolation and, in turn, the water table buildup:

**Table 1** Approximate deep percolation from surface irrigation (percent of net input) <sup>1/</sup>

| By texture |         |         |         | By infiltration rate |        |                          |             |        |                          |
|------------|---------|---------|---------|----------------------|--------|--------------------------|-------------|--------|--------------------------|
| Texture    | Percent | Texture | Percent | -Inf. rate-          |        | Deep percolation percent | -Inf. rate- |        | Deep percolation percent |
|            |         |         |         | mm/h                 | (in/h) |                          | mm/h        | (in/h) |                          |
| LS         | 30      | CL      | 10      | 1.27                 | (0.05) | 3                        | 25.4        | (1.00) | 20                       |
| SL         | 26      | SiCL    | 6       | 2.54                 | (.10)  | 5                        | 31.8        | (1.25) | 22                       |
| L          | 22      | SC      | 6       | 5.08                 | (.20)  | 8                        | 38.1        | (1.50) | 24                       |
| SiL        | 18      | C       | 6       | 7.62                 | (.30)  | 10                       | 50.8        | (2.00) | 28                       |
| SCL        | 14      |         |         | 10.2                 | (.40)  | 12                       | 63.5        | (2.50) | 31                       |
|            |         |         |         | 12.7                 | (.50)  | 14                       | 76.2        | (3.00) | 33                       |
|            |         |         |         | 15.2                 | (.60)  | 16                       | 102.0       | (4.00) | 37                       |
|            |         |         |         | 20.3                 | (.80)  | 18                       |             |        |                          |

<sup>1/</sup> These values should be used only for preliminary planning. More detailed investigations of deep percolation are required for project designs.

**Example 1**

Assume the irrigation application is known to be 150 millimeters (about 6 inches) per irrigation, soils in the root zone have a loam texture with an infiltration rate of 25 millimeters (1 inch) per hour, and about 10 percent of the 150-millimeter (6-inch) application runs off.

The net input of water into the soil per irrigation would then be 90 percent of the 150-millimeter (6-inch) application, or 135 millimeters (5.4 inches). From table 1, the deep percolation would be 20 percent for an infiltration rate of 25 millimeters (1 inch) per hour. Therefore, the deep percolation is  $135 \times 0.20 = 27$  millimeters (1.08 inches). If the hydraulic conductivity in the zone between the root zone and the drain depth is 25 millimeters (1 inch) per hour, then the specific yield corresponding to this hydraulic conductivity is 10 percent, as given by figure 3. The buildup of the water table per irrigation is the deep percolation divided by the specific yield, or millimeters (10.8 inches).

$$\frac{27}{0.10} = 270 \text{ mm (10.8 in)}$$

**Example 2**

Assume the total readily available moisture in the root zone (allowable consumptive use between irrigations) has been determined as 107 millimeters (4.2 inches) and that the infiltration rate of the soil in the area is 25 millimeters (1 inch) per hour with a corresponding deep percolation of 20 percent.

$$\frac{107}{0.80} = 134 \text{ mm (5.25 in)}$$

The net input of water into the soil per irrigation will be 134 millimeters (5.25 inches), where  $0.80 = 1.00 - 0.20$ . The deep percolation will be  $134 - 107 = 27$  millimeters (1.05 inches). The buildup in the water table per irrigation would be this deep percolation amount divided by the specific yield in the zone between the drain and the maximum allowable water table.

Rainfall in arid areas is usually, but not necessarily, so small that the effects of deep percolation from this source during the irrigation season can be neglected. In semi-humid areas, deep percolation from rain may be appreciable and must be accounted for in estimating subsurface drainage requirements. When it is apparent that precipitation is a significant source of soil moisture and deep percolation, the curve of figure 6 can be used to estimate the infiltrated precipitation. This infiltrated precipitation can then be used to determine the resultant irrigation schedule and the amount and timing of deep percolation from rainfall and irrigation. In areas that frequently have 3 or 4 days of rainfall separated by only 1 or 2 rainless days, the transient flow methods yield more accurate values for discharge if the accumulated deep percolation from infiltrated precipitation is assumed to occur on the last day of rain.

Deep percolation from spring snowmelt occurs in some areas and should be accounted for where possible. In some areas the buildup in the water table from this snowmelt can be measured in observation wells and used directly in the spacing computations. In others the estimate may need to be based entirely on judgment and general knowledge of the area.

### Using the data

The method of using the data described in the previous section to obtain dynamic equilibrium is briefly described in this section. A more detailed description is given in examples shown in subsequent sections. A computer program has also been developed by Reclamation personnel to perform drain spacing computations and analyze return flows for salinity studies.

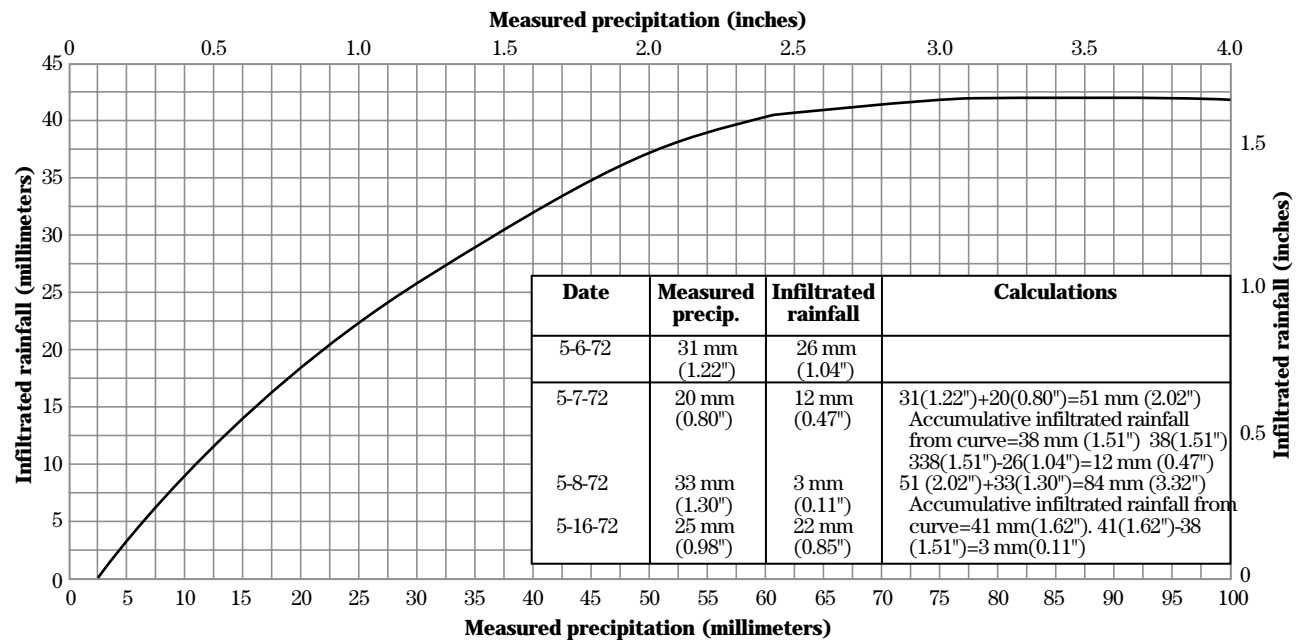
The drain spacing computations have been adapted for use on a personal computer. This program is called the Agricultural Drainage Planning Program (ADPP). The program manual and disks are available through the Superintendent of Documents, U.S. Government Printing Office.

Begin the calculations by assuming a drain spacing,  $L$ , and the assumption that the water table reaches its maximum allowable height,  $y_o$ , immediately after the last irrigation application of each season. At least two successive positions of the water table are calculated during the nonirrigation season (even in areas of

year-round cropping, a slack period occurs sometime during the year). Then the buildup and drainout from each irrigation is calculated for the irrigation season. If the assumed spacing results in dynamic equilibrium conditions, the water table height at the end of the series of calculations for the irrigation season will equal the maximum allowable water table height,  $y_o$ . If  $y_o$  after the last irrigation is not equal to the maximum allowable  $y_o$ , the procedure is repeated with a different  $L$ . Normally, only two drain spacing assumptions are necessary to verify the dynamic equilibrium-producing spacing. A straight-lined relation between two assumed spacings and their resulting values of  $y_o$  after a complete annual cycle will permit determination of the proper spacing if the original assumptions are reasonably close.

Where the annual hydrograph peaks at some time other than the end of the irrigation season, the normal high point should be used as a starting point for calculations. This high point often occurs in the spring where sprinkler irrigation is used in semiarid or sub-humid climates.

**Figure 6** Curve for estimating infiltrated rainfall



### Drain above the barrier layer

The following example is given to illustrate the method of determining the drain spacing for a drain above the barrier. The following conditions are assumed:

- The distance from the barrier to the drain,  $d$ , is 6.7 meters (22 feet), and the depth of the drain is 2.4 meters (8 feet).
- The root zone requirement is 1.2 meters (4 feet), which gives a maximum allowable water table height,  $y_o$ , above the drain of  $2.4 - 1.2 = 1.2$  meters ( $8 - 4 = 4$  feet).
- The weighted average hydraulic conductivity in the zone between the barrier and the maximum allowable water table height is 127 millimeters (5 inches) per hour, or 3.05 meters (10 feet) per day.
- The hydraulic conductivity is uniform with depth. Therefore, the hydraulic conductivity in the zone between the maximum allowable water table height and the drain is also 127 millimeters (5 inches) per hour. From figure 3, the corresponding value of specific yield is 18 percent.
- The deep percolation from each irrigation (also assumed to be the same from a spring snowmelt) is 25.4 millimeters (1 inch), or 0.0254 meter (0.083 foot). The water table buildup from each increment of recharge is the deep percolation divided by the specific yield, or

$$\frac{.0254}{0.18} = 0.14 \text{ meter (0.46 ft)}$$

- The approximate dates of the snowmelt and the irrigation applications are as follows:

| Irrigation or snowmelt (sm) | Date        | Time between irrigations, days |
|-----------------------------|-------------|--------------------------------|
| SM                          | April 22    |                                |
| First                       | June 6      | 45                             |
| Second                      | July 1      | 25                             |
| Third                       | July 21     | 20                             |
| Fourth                      | August 4    | 14                             |
| Fifth                       | August 18   | 14                             |
| Sixth                       | September 1 | 14                             |
|                             |             | 132                            |

Therefore, the nonirrigation period is 233 days (365 – 132). As previously mentioned, this period should be divided into two or three approximately equal periods; for this example, use two periods: one of 116 days and one of 117 days.

A drain spacing,  $L$ , of 442 meters (1,450 feet) resulted from two prior trial calculations. Assuming that the water table reaches the maximum allowable height immediately after the application of the last irrigation of each season, the computations begin at this point in time.

The first step in applying the method is to compute the value for the first time period.

$$\frac{KDt}{SL^2}$$

Using this value, the value of  $y$  divided by  $y_o$  is then found from figure 2. Knowing the initial  $y_o$ , we can then calculate  $y$ , the height to which the midpoint water table falls during this period. This process is repeated for each successive period, which results in a water table height for each successive recharge and drainout. The process is shown in table 2.

#### Explanation of each column in table 2

Column 1—Number of each successive increment of recharge, such as snowmelt (SM), rain, or irrigation.

Column 2—Length of drainout period (time between successive increments of recharge or between incremental drainout periods).

Column 3—Instantaneous buildup from each recharge increment (deep percolation divided by specific yield).

Column 4—Water table height above drains at midpoint between drains immediately after each buildup or at beginning of incremental time periods during the nonirrigation season drainout (col. 8 of preceding period plus col. 3 of current period).

Column 5—Average depth of flow,

$$D = d + \frac{y_o}{2} \quad (d \text{ should be limited to } \frac{L}{4}).$$

Column 6—A calculated value representing the flow conditions during any particular drainout period:

$$\frac{K}{SL^2} \times \text{col. 5} \times \text{col. 2}$$

Column 7—Value taken from the curve on figure 2.

Column 8—Midpoint water table height above drain at end of each drainout period, col. 4 x col. 7.

Table 2 shows a final  $y_o = 1.235$  meters (4.04 feet), which is approximately equal to the maximum allowable  $y_o$  of 1.22 meters (4.00 feet). Therefore, the spacing of 442 meters (1,450 feet) results in dynamic equilibrium. As stated previously, this spacing solution does not account for head loss due to convergence.

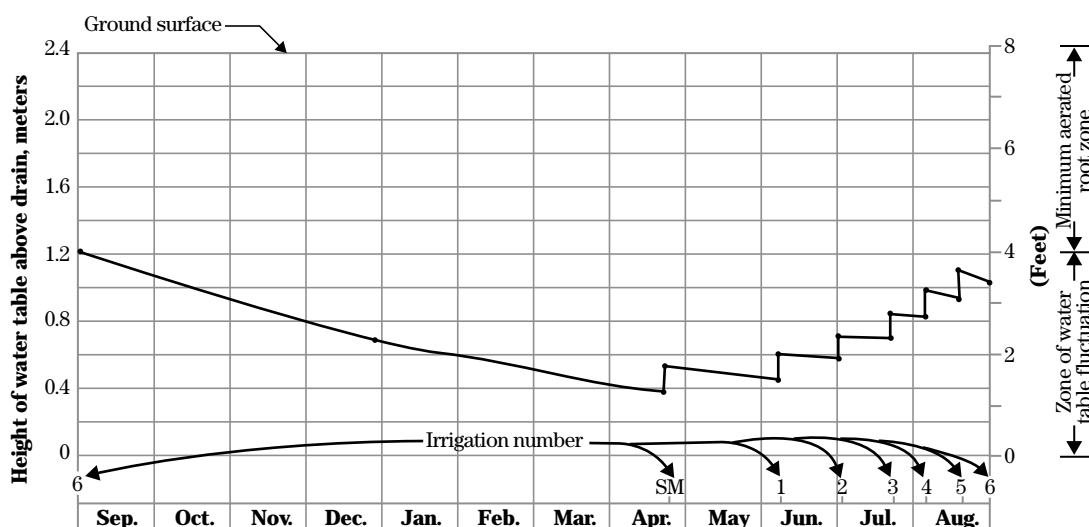
Using Hooghoudt's method of correcting for convergence and using figure 4, we find that for  $d = 6.7$  meters (22 feet) and a drain spacing of 442 meters (1,450 feet), the equivalent depth,  $d'$ , is 6.1 meters (20 feet). The  $D'$  to be used in the drain spacing computations is:

$$D' = d' + \frac{y_o}{2} = 6.1 + \frac{y_o}{2}$$

The trial and error approach is again used to find the corrected spacing of 427 meters (1,400 feet). Table 3 shows the results of using  $D'$  with a spacing of 427 meters (1,400 feet).

The calculations in table 3 result in essentially the same water table heights,  $y_o$ , that were obtained in the previous calculations in table 2 and verify the 427-meter (1,400-foot) spacing as corrected for convergence. Figure 7 illustrates the water table fluctuation produced as a result of the conditions of this example.

**Figure 7** Water table fluctuation



**Table 2** Computation of water table fluctuation with drain on the barrier layer**(a) meters**

| (1)<br>Irrigation<br>no. | (2)<br>Period,<br>t, days | (3)<br>Buildup per<br>irrigation,<br>meters | (4)<br>$y_o$ ,<br>meters | (5)<br>$D'$ ,<br>meters | (6)<br>$\frac{KDt}{SL^2}$ | (7)<br>$\frac{y}{y_o}$ | (8)<br>y,<br>meters |
|--------------------------|---------------------------|---|--------------------------|-------------------------|---------------------------|------------------------|---------------------|
| 6                        | 117                       |   | 1.22                     | 7.31                    | 0.0742                    | 0.575                  | 0.701               |
|                          | 116                       |   | 0.701                    | 7.05                    | .0710                     | .590                   | 0.414               |
| SM                       | 45                        | 0.140                                       | 0.554                    | 6.98                    | .0272                     | .870                   | 0.482               |
| 1                        | 25                        | .140  | 0.622                    | 7.01                    | .0152                     | .958                   | 0.596               |
| 2                        | 20                        | .140  | 0.736                    | 7.07                    | .0123                     | .978                   | 0.720               |
| 3                        | 14                        | .140  | 0.860                    | 7.13                    | .0087                     | .985                   | 0.847               |
| 4                        | 14                        | .140  | 0.987                    | 7.19                    | .0087                     | .985                   | 0.972               |
| 5                        | 14                        | .140  | 1.112                    | 7.26                    | .0088                     | .985                   | 1.095               |
| 6                        |                           | .140  | 1.235                    |                         |                           |                        |                     |

**(b) feet**

| (1)<br>Irrigation<br>no. | (2)<br>Period,<br>t, days | (3)<br>Buildup per<br>irrigation,<br>feet | (4)<br>$y_o$ ,<br>feet | (5)<br>$D'$ ,<br>feet | (6)<br>$\frac{KDt}{SL^2}$ | (7)<br>$\frac{y}{y_o}$ | (8)<br>y,<br>feet |
|--------------------------|---------------------------|---|------------------------|-----------------------|---------------------------|------------------------|-------------------|
| 6                        | 117                       |   | 4.00                   | 24.00                 | 0.0742                    | 0.575                  | 2.30              |
|                          | 116                       |   | 2.30                   | 23.15                 | .0710                     | .590                   | 1.35              |
| SM                       | 45                        | 0.46                                      | 1.82                   | 22.91                 | 0.272                     | .870                   | 1.58              |
| 1                        | 25                        | .46                                       | 2.04                   | 23.02                 | .0152                     | .958                   | 1.95              |
| 2                        | 20                        | .46                                       | 2.41                   | 23.20                 | .0123                     | .978                   | 2.36              |
| 3                        | 14                        | .46                                       | 2.81                   | 23.41                 | .0087                     | .985                   | 2.77              |
| 4                        | 14                        | .46                                       | 3.22                   | 23.61                 | .0087                     | .985                   | 3.17              |
| 5                        | 14                        | .46                                       | 3.63                   | 23.82                 | .0088                     | .985                   | 3.58              |
| 6                        |                           | .46                                       | 4.04                   |                       |                           |                        |                   |



**Table 3** Computation of water table fluctuation with drain on the barrier layer using  $D'$  as corrected by Hooghoudt**(a) meters**

| (1)<br>Irrigation<br>no. | (2)<br>Period,<br>t, days | (3)<br>Buildup per<br>irrigation,<br>meters | (4)<br>$y_o$ ,<br>meters | (5)<br>$D'$ ,<br>meters | (6)<br>$\frac{KDt}{SL^2}$ | (7)<br>$\frac{y}{y_o}$ | (8)<br>y,<br>meters |
|--------------------------|---------------------------|---|--------------------------|-------------------------|---------------------------|------------------------|---------------------|
| 6                        | 117                       |   | 1.22                     | 6.71                    | 0.0730                    | 0.565                  | 0.69                |
|                          | 116                       |   | 0.689                    | 6.44                    | .0695                     | .600                   | 0.41                |
| SM                       |                           | 0.140                                       |                          |                         |                           |                        |                     |
|                          | 45                        |   | 0.554                    | 6.73                    | .0267                     | .870                   | 0.48                |
| 1                        |                           | .140  |                          |                         |                           |                        |                     |
|                          | 25                        |   | 0.622                    | 6.41                    | 0.149                     | .955                   | 0.59                |
| 2                        |                           | .140  |                          |                         |                           |                        |                     |
|                          | 20                        |   | 0.736                    | 6.46                    | 0.120                     | .970                   | 0.71                |
| 3                        |                           | .140  |                          |                         |                           |                        |                     |
|                          | 14                        |   | 0.856                    | 6.52                    | .0085                     | .986                   | 0.84                |
| 4                        |                           | .140  |                          |                         |                           |                        |                     |
|                          | 14                        |   | 0.987                    | 6.59                    | .0086                     | .986                   | 0.97                |
| 5                        |                           | .140  |                          |                         |                           |                        |                     |
|                          | 14                        |   | 1.112                    | 6.65                    | .0087                     | .985                   | 1.09                |
| 6                        |                           | .140  |                          |                         |                           |                        |                     |
|                          |                           |   | 1.235                    |                         |                           |                        |                     |

**(b) feet**

| (1)<br>Irrigation<br>no. | (2)<br>Period,<br>t, days | (3)<br>Buildup per<br>irrigation,<br>feet | (4)<br>$y_o$ ,<br>feet | (5)<br>$D'$ ,<br>feet | (6)<br>$\frac{KDt}{SL^2}$ | (7)<br>$\frac{y}{y_o}$ | (8)<br>y,<br>feet |
|--------------------------|---------------------------|---|------------------------|-----------------------|---------------------------|------------------------|-------------------|
| 6                        | 117                       |   | 4.00                   | 22.00                 | 0.0730                    | 0.565                  | 2.26              |
|                          | 116                       |   | 2.30                   | 21.13                 | .0695                     | .600                   | 1.36              |
| SM                       |                           | 0.46                                      |                        |                       |                           |                        |                   |
|                          | 45                        |   | 1.82                   | 20.91                 | .0267                     | .870                   | 1.58              |
| 1                        |                           | .46                                       |                        |                       |                           |                        |                   |
|                          | 25                        |   | 2.04                   | 21.02                 | .0149                     | .955                   | 1.95              |
| 2                        |                           | .46                                       |                        |                       |                           |                        |                   |
|                          | 20                        |   | 2.41                   | 21.21                 | .0120                     | .970                   | 2.34              |
| 3                        |                           | .46                                       |                        |                       |                           |                        |                   |
|                          | 14                        |   | 2.80                   | 21.40                 | .0085                     | .986                   | 2.76              |
| 4                        |                           | .46                                       |                        |                       |                           |                        |                   |
|                          | 14                        |   | 3.22                   | 21.61                 | .0086                     | .986                   | 3.17              |
| 5                        |                           | .46                                       |                        |                       |                           |                        |                   |
|                          | 14                        |   | 3.63                   | 21.82                 | .0087                     | .985                   | 3.58              |
| 6                        |                           | .46                                       |                        |                       |                           |                        |                   |
|                          |                           |   | 4.04                   |                       |                           |                        |                   |

---

## Drain on the barrier layer

Example 3 illustrates the method for determining the drain spacing for a drain on the barrier.

### Example 3

All assumptions are the same as those in the previous example above except that  $d$  in this example is zero. The assumption of a drain spacing and subsequent computations of water table heights are also similar to those for a drain above the barrier.

A drain spacing of 125 meters (410 feet) is assumed, and subsequent computations are shown in table 4.

Table 4 shows a final  $H = 1.243$  meters (4.08 feet), which is essentially equal to the maximum allowable  $H$  of 1.22 meters (4.00 feet). Therefore, the spacing of 125 meters (410 feet) results in dynamic equilibrium, and because no correction for convergence is required for this case, the final drain spacing is 125 meters (410 feet).

**Table 4** Computation of water table fluctuation with drain on the barrier layer**(a) meters**

| Irrigation no. | t, days | Buildup per irrigation, meters | H meters | $\frac{KHt}{SL^2}$ | $\frac{Z}{H}$ | Z, meters |
|----------------|---------|--------------------------------|----------|--------------------|---------------|-----------|
| 6              | 117     |                                | 1.22     | 0.1546             | 0.590         | 0.719     |
|                | 116     |                                | 0.719    | .0905              | .720          | 0.518     |
| SM             |         | 0.140                          |          |                    |               |           |
|                | 45      |                                | 0.658    | .0321              | .900          | 0.591     |
| 1              |         | .140                           |          |                    |               |           |
|                | 25      |                                | 0.732    | .0199              | .945          | 0.691     |
| 2              |         | .140                           |          |                    |               |           |
|                | 20      |                                | 0.832    | .0180              | .950          | 0.789     |
| 3              |         | .140                           |          |                    |               |           |
|                | 14      |                                | 0.930    | .0141              | .975          | 0.911     |
| 4              |         | .140                           |          |                    |               |           |
|                | 14      |                                | 1.051    | .0159              | .970          | 1.015     |
| 5              |         | .140                           |          |                    |               |           |
|                | 14      |                                | 1.158    | .0176              | .955          | 1.103     |
| 6              |         | .140                           |          |                    |               |           |
|                |         |                                | 1.243    |                    |               |           |

**(b) feet**

| Irrigation no. | t, days | Buildup per irrigation, feet | H feet | $\frac{KHt}{SL^2}$ | $\frac{Z}{H}$ | Z, feet |
|----------------|---------|------------------------------|--------|--------------------|---------------|---------|
| 6              | 117     |                              | 4.00   | 0.1546             | 0.590         | 2.36    |
|                | 116     |                              | 2.36   | .0905              | .720          | 1.70    |
| SM             |         | 0.46                         |        |                    |               |         |
|                | 45      |                              | 2.16   | .0321              | .900          | 1.94    |
| 1              |         | .46                          |        |                    |               |         |
|                | 25      |                              | 2.40   | .0199              | .945          | 2.27    |
| 2              |         | .46                          |        |                    |               |         |
|                | 20      |                              | 2.73   | .0180              | .950          | 2.59    |
| 3              |         | .46                          |        |                    |               |         |
|                | 14      |                              | 3.05   | .0141              | .975          | 2.99    |
| 4              |         | .46                          |        |                    |               |         |
|                | 14      |                              | 3.45   | .0159              | .970          | 3.33    |
| 5              |         | .46                          |        |                    |               |         |
|                | 14      |                              | 3.80   | .0176              | .955          | 3.62    |
| 6              |         | .46                          |        |                    |               |         |
|                |         |                              | 4.08   |                    |               |         |



A drainage problem may exist around a home if the basement is wet, the yard is flooded periodically, water ponds on a lawn for long period after a rain, or trees, shrubs, and other plants grow poorly. About 20 percent of the land in the United States is affected by excess water. Wetness generally is caused by flooding, springs and seeps, seasonal high water tables, ponding of surface water, or slow soil permeability.

Following are some of the more common causes of wet or damp basements:

- The land is flat or slopes toward the house, permitting surface water (rain and melting snow) to drain down against the basement walls. Water leaks through cracks or other openings in the walls and causes wet spots on the walls or standing water on the floor.
- No gutters and downspouts (or defective ones) to handle roof water from rain and snow. The free-falling water forms puddles or wet soil near or against the basement walls. Water leaks in or enters by capillarity.
- The ground water level is close to the underside of the floor slab. Water rises through the slab by capillarity, producing dampness.
- The ground water level is higher than the basement floor. Water leaks in or enters by capillarity, causing standing water in the basement and, at times, dampness in the rooms above.
- Condensation (sweating) of atmospheric moisture on cool surfaces—walls, floor, cold-water pipes—in the basement.
- Leaky plumbing or other sources of moisture increase the humidity of the basement air. Dense shrubbery and other plantings around the basement walls prevent good ventilation.
- Existing drainage system around the basement or foundation have not been properly maintained.

### Selection of building site

With proper site selection and planning, many of these causes can be prevented. General information on soil conditions, seasonal high water tables and so forth may be found in the local soil survey report.

An important consideration in selecting the site for a new house is proper drainage. This includes not only

drainage of surface, but also drainage of any subsurface or ground water that may be present or that may accumulate over a period of time and be blocked from its normal course of flow by the new construction.

The highest point on the property is often the best building site and provides the best surface drainage (fig. 1a). An elevated site provides good surface drainage away from the house in all directions.

Second choice might be a hillside (fig. 1b). The advantage of such a location is that drainage water can be routed around the high side of the house for runoff at the ends and low side.

If the site is flat, the ground around the house must be built up or graded to drain surface water away from the basement walls or foundation (fig. 1c).

The surface soil and subsoil should be open and porous so that air and water are admitted readily. Desirable soils include sands, loams, and gravels which provide good, deep, natural drainage. Under ideal conditions, the soil is so well drained that during the rainy season the subsurface or ground water level is at least 10 feet below the finished grade. Water at that level is well below the level of the average basement floor.

### Flooding

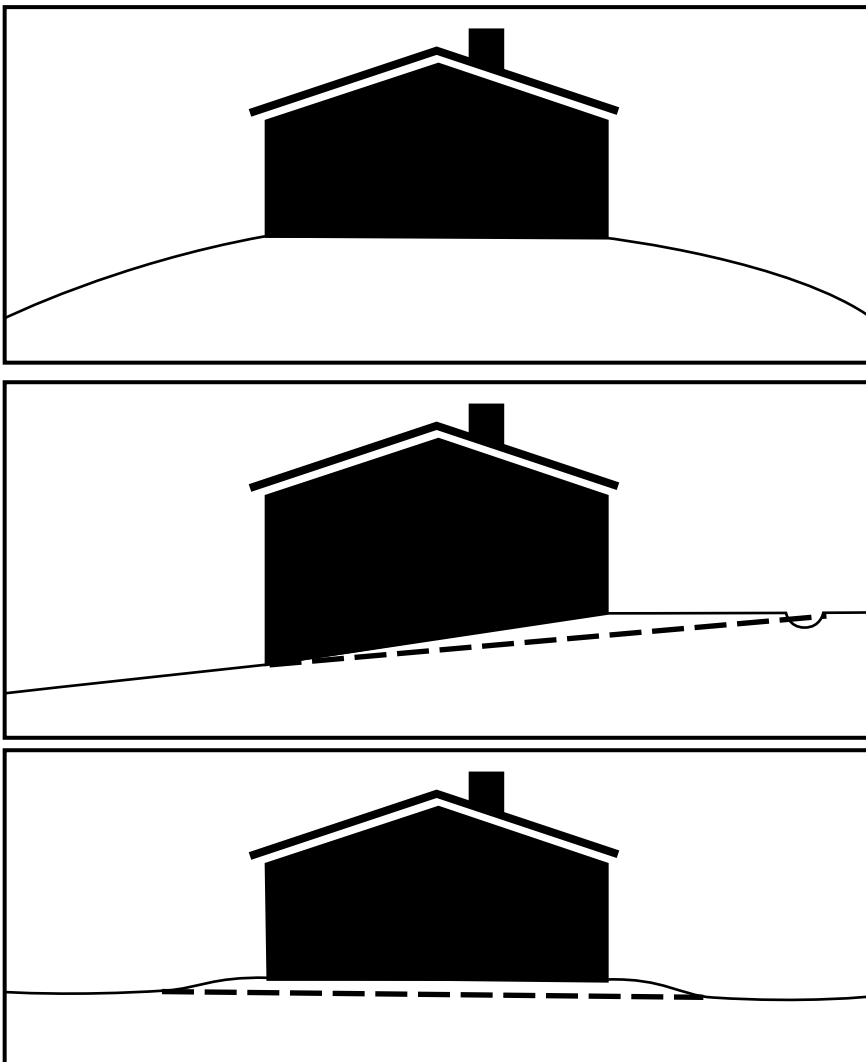
If a home is in the flood plain of a nearby stream or creek, it may be flooded if the stream overflows during periods of heavy rainfall or rapid snowmelt. Usually community-wide measures are needed to ensure adequate protection. Floodproofing a house may reduce damage, but is not always effective against severe floods. Floodproofing measures can include diking, provisions for blocking opening such as windows and doors, regulating drain outlets, and waterproofing walls. Floodproofing measures can be expensive and require careful evaluation to prevent structural damage. When selecting a home site, be sure the site is not highly floodprone. The house foundation should be built above any expected flood level. Local government planning offices should have information designating floodprone areas.

In upland areas, flooding can occur if a house is built in the path of a natural drainageway or in a pothole or

site that is lower than the surrounding area. A drainageway or low area may appear safe in dry seasons, but carry runoff water in wet seasons. In housing developments where the landscape has been greatly modified, natural drainageways are often blocked or altered. If man-made drainageways or storm sewers

are not built to carry the seasonal flow of water, nearby homes may be flooded. Runoff from areas as small as one acre or less can cause flooding. Measures to remedy this kind of hazard usually require the cooperation of several homeowners.

**Figure 1** Selection of building sites



(a) An elevated site provides good surface drainage away from the house in all directions.

(b) Drainage can be routed around a side hill located house (note drainage ditch on uphill side).

(c) On a flat site, the ground around the house must be built up to drain water away from the basement walls.

## Springs and seeps

On many sites, natural springs and seeps occur because of existing soil, rock, and landscape characteristics. Water may flow throughout the year or only seasonally during periods of heavy rainfall.

Water may flow into or around a house if it is constructed over or near a spring or seep. For protection, it is a good practice to install subsurface drains, at least 4 inches in diameter and surrounded with 6 to 12 inches of gravel or sand and gravel, along the outside of the foundation wall (fig. 2).

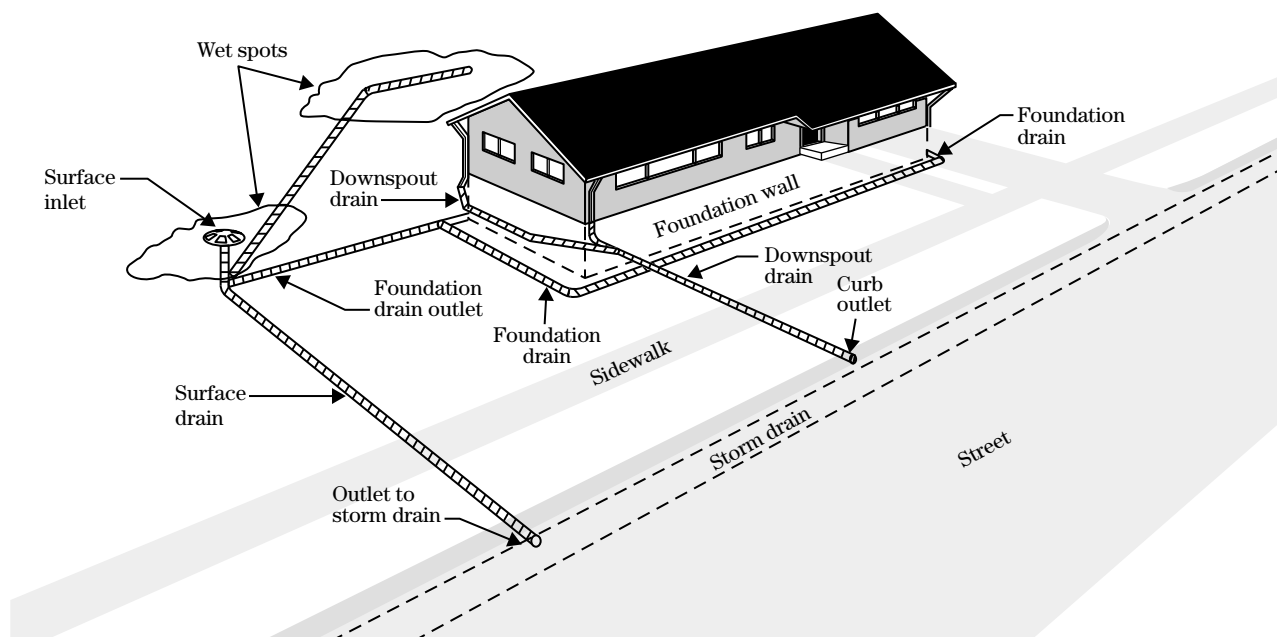
Springs and seeps also affect lawns and onsite fields. Following local building codes and health department regulations, subsurface drains may be installed to collect the ground water and divert it from such areas.

The most commonly used material is currently perforated corrugated plastic pipe. Local building codes and other drainage regulations should be checked for approved materials, controls of discharge into storm sewers, road ditches, street gutters, and so forth. Existing subsurface drains may be made of clay and concrete tile, perforated plastic, metal, asbestos-cement, or bituminous wood fiber. Homeowners can check their site plans for these existing drains.

## Seasonal high water table

A water table can be defined as the upper surface of ground water or the level below which the soil is saturated with water. This level may fluctuate by several feet throughout the year depending on soil, landscape, and weather conditions. In many areas of the United States, especially where annual rainfall is 20 inches or more, the seasonal high water table is 2 to 5 feet below the surface.

**Figure 2** Subsurface drains can be installed around a home to remove excess water



In selecting a new home site, the level of the seasonal high water table is a very important consideration. On some sites the seasonal high water table may be at or near the ground surface for long periods. These areas should be avoided. If the water table is 6 feet deep or more, it may be of little concern for houses without basements.

When building a new house, a sump pump with a system of subsurface drains can be used to lower the water table. A good outlet is needed for the discharge flow from the pump. A safer method is to limit excavation and build the house on a reinforced concrete slab above the seasonal high water table.

If a house is already built, drains can be installed around the outside wall or under the basement floor. Lowering the water table under the basement floor should be done with caution. On some soils, especially slow-draining silts and clays, unequal settlement may crack the walls.

On lawns, where only a small part is affected by a high water table, a small excavated pond may be a suitable remedy. The nuisance wet area can be developed into an attractive landscaping feature. Before building a pond, state and local safety regulations that apply to pond construction should be checked.

## Ponding of surface water

If surface water ponds on a lawn or driveway, small diversions or ditches can be installed to channel off the water. In developed residential areas, these structures usually are installed near property lines behind or beside houses.

For low flows of surface water, a surface inlet leading to a subsurface drain can be installed. The drain outlet can empty into street gutters or storm sewers if permitted by local building codes and other drainage regulations.

A lawn should be graded so that surface water drains away from the house. A minimum grade of 1 foot in 100 feet (1/8) inch per foot) is generally adequate. When filling in low areas during grading, use the most permeable soil available. The topsoil should be saved and spread over the newly filled and graded areas to

help establish vegetation. Sodding prevents the washing away of newly graded area during heavy rains.

When a large area of land slopes toward the house, surface drainage should be intercepted and rerouted some distance from the house. A shallow, half round drainage ditch or depression designed to route the water around the house (fig. 1b) should be installed. The ditch should be sodded or seeded to grass. If the ditch is objectionable, corrugated plastic drainage tubing with one or more catch basins at low spots may be installed.

## Roof water

Houses should have gutters and downspouts to take care of roof water from rain and snow. The gutters and downspouts should be kept free of debris. Where leaves and twigs from nearby trees may collect in a gutter, a basket-shaped wire strainer may be installed over the downspout outlet. Gutters and downspouts should be repaired and painted as soon as the need appears.

Downspouts usually have an elbow or shoe on the lower end to discharge the water slightly above the ground and away from the foundation or basement wall. To prevent concentration of water at the point of discharge, a concrete gutter or a splash should be used to carry the water away. The gutter or block should slope one inch per foot, and its edges should be flush with the grade.

Disposal of roof water as shown in figure 3 makes it easy to clear clogged downspouts. Roof water can also be piped underground to a storm water drain, dry well, or surface outlet, 15 feet or more from the house (fig. 4). The bottom of a dry well should be lower than the basement floor and in earth or rock that drains rapidly.

Installing suitable downspouts to control roof water may be adequate to prevent ponding in low areas of a yard. Downspouts can empty into a subsurface drain or into outlet spreaders installed to discharge water in a thin layer over a grassy area.



## Slow soil permeability

If the soil at a home site has a slowly permeable layer, especially a layer of clay, flow of water through the soil may be restricted and water may pond on a lawn. If the layer with slow permeability is near the surface, a small trench can be dug through the layer and filled with sand, gravel, pine bark, sawdust, or other coarse material to improve permeability in a small, low-lying wet spot. For larger wet areas, subsurface drains may be required.

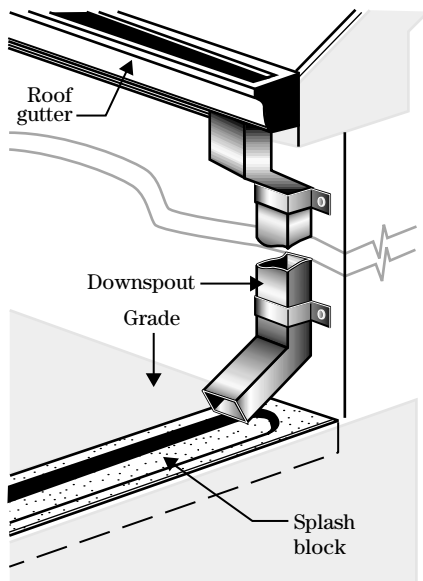
Even on well drained soil, heavy foot traffic during wet periods compacts soil and reduces permeability. Restricting foot traffic in the wet lawn helps prevent soil compaction.

## Maintenance

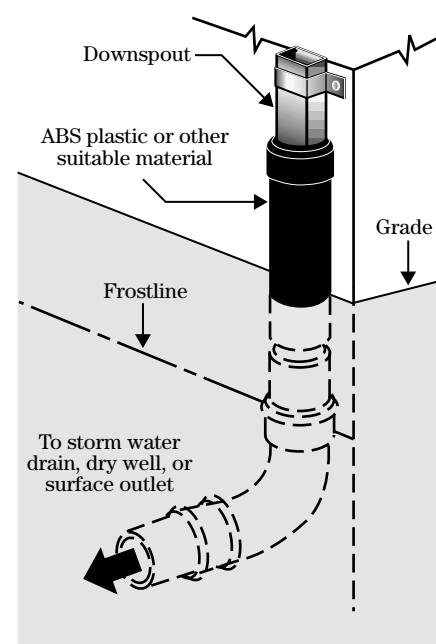
To continue their usefulness, drains require periodic maintenance. Gates and screens of outlets must be checked to assure that entry of rodents and other small animals is restricted and that they are free of sediment buildup, weeds, debris, and seasonal ice blocks. Where drainage outlets extend beyond the property line, check with the local governmental entity such as drainage district or the county to determine maintenance responsibility.

General observation of the existing system will reveal possible need for maintenance. Sinkholes or cave-ins over the drains indicate a broken or collapsed drainage conduit or an opening in the filter or envelop material that allows soil material to enter the drain. Unusual wetness of the basement wall or foundation, surface puddles, or wet areas can indicate a plugged line or filter fabric.

**Figure 3** Correctly installed gutters and downspouts prevent roof water from forming wet or damp conditions around foundation or basement walls



**Figure 4** Roof water can be routed away from the foundation or basement walls to a storm water drain or other outlet using non-perforated pipe



## Foundation and basement construction

Constructions required for foundation and basement walls and floor depends largely upon soil drainage conditions. In well-drained soil, good, water-resistant construction may be adequate. In poorly drained soil or where the basement floor will be below the subsurface water level, watertight construction is required.

Construction plans complying with local building codes and architectural guidelines plans should be followed for construction of foundation and basement walls and floors and associated footing drains. (fig. 5)

## References

American Society of Civil Engineers. 1998. Urban subsurface drainage manual of engineering. Practice No. 95, Reston, VA, 190 pp.

United States Department of Agriculture, Agricultural Research Service. 1970. Home and Garden Bulletin No. 115. U.S. Gov. Print. Office.

United States Department of Agriculture, Soil Conservation Service. 1975. Drainage around your home. Home and Garden Bulletin No. 210. U.S. Gov. Print. Office.

**Figure 5** Foundation drain application

