

# Horse Stable Ventilation

**A**lthough horse enthusiasts have a wide variety of riding-driving disciplines, breeds, and interests, all agree that good air quality inside their horse’s stable is important. Veterinarians and professional horse handlers recommend good ventilation for stabled horses to maintain respiratory health. We know that the stable should smell like fresh forage and clean horses rather than manure or ammonia. Yet, failure to provide adequate ventilation is the most common mistake made in construction and management of modern horse facilities.

**Inadequate ventilation is the most common mistake made in modern horse facilities.**

Why would such a universally agreed upon feature be overlooked in stable design? Are we placing human needs over horse comfort? Have building designers and owners

lost perspective of the features of a well-ventilated stable? There is a trend toward residential construction practices in horse housing. Horses are considered livestock when it comes to housing design, despite the fact that they are our companions and pets. This publication outlines proven practices of ventilation that have been successfully used in maintaining good air quality in horse facilities. Although the emphasis is on stables with box stalls to each side of a central aisle, the principles are equally effective in

maintaining good air quality in other stable layouts and in run-in-sheds or indoor riding arenas.

## What Is Ventilation?

The objective of ventilation is to provide fresh air to the horse. Ventilation is achieved by simply providing sufficient openings in the building so that fresh air can enter and stale air will exit. There are ways to provide each stabled horse with access to fresh air all the time. The stable will have “holes” in it to admit air; it cannot be constructed tight as a thermos bottle like our own homes. Compared to our homes, stables have much more moisture, odor, mold, and dust being added to the air, not to mention manure being deposited within the facility.

Ventilation is needed to remove heat from the stable in hot weather. It is beneficial to provide a cooling breeze over the horse, which is more comfortable than hot, still air. During warm weather the stable doors and windows are usually open to aid in moving air through the stable.

## Table of Contents

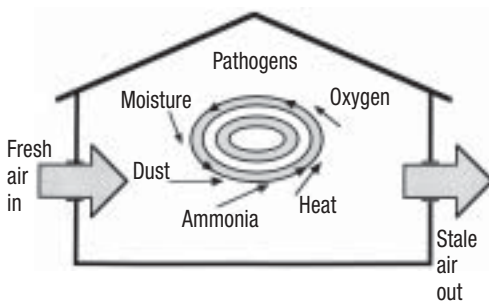
- What Is Ventilation? ..... 1
- Common Ventilation Questions ..... 2
- Recommendations for Providing Effective Natural Ventilation ..... 5
- Three Design Features to Improve Horse Stall Ventilation ..... 13
- Why Inadequate Ventilation? ..... 15
- Measuring Ventilation Rate ..... 15
- Summary ..... 16
- Acknowledgements ..... 16
- Additional Resources ..... 16



During cold weather, the stable is often managed with closed windows and doors to keep chilling winter winds off the horse. In winter, the ventilation goal changes from heat removal to controlling moisture, odor, and ammonia that have built up in the more closed environment of the stable. Moisture comes from horse respiration and other stable activities such as horse bathing and facility cleaning. With moisture buildup, comes increased risk of condensation, intense odor, more ammonia release, and pathogen viability, which contributes to respiratory infection.

Ventilation involves two simple processes (Figure 1). One is “air exchange,” where stale air is replaced with fresh air, and the second is “air distribution,” where fresh air is available throughout the stable. Proper ventilation provides both; one without the other is not adequate ventilation. For example, it is not good enough to let fresh air into the stable through an open door at one end of the building if that fresh air is not distributed throughout the horse stalls. Nor is proper ventilation satisfied if a tightly closed stable uses interior circulation fans to move stale air around the facility.

**Figure 1. Air exchange and air distribution are the two ventilation processes.**



## Common Ventilation Questions

### *What are comfortable conditions?*

A horse’s most comfortable temperature range is between 45 and 75°F. Our most comfortable human temperature is at the upper end of the horse comfort zone. Clearly, horses tolerate cold very well and adapt to chilling breezes when housed outside. If conditioned to cold weather, horses with long-hair coats and adequate nutrition can withstand temperatures below 0°F. Even show horses with a short-hair coat can be maintained in a cold but dry indoor facility when provided with blankets and hoods. Within a box stall, horses have the freedom to move away from uncomfortable conditions.

### *What is a well-ventilated stable going to feel like?*

The stable environment in winter is almost as cold as outdoors but comfortably dry with no condensation dripping from the structure. Cold and humid conditions are uncomfortable for both horse and human and lead to a stuffy, dank environment within the stall. Upon first entering a stable, make an objective evaluation about its air quality before you have adapted to those conditions. In hot weather, the stable temperature will be within a few degrees of outdoors and more comfortable due to shading from the sun.

During winter, horse stables should be kept no more than 5 to 10°F warmer than the outside temperature. This guideline helps assure fresh air conditions, but it also means freezing will occur inside stables in northern climates. It is a management mistake with regards to air quality and to your horses’ health to close the barn tight just to keep conditions above freezing in cold weather. If condensation occurs on interior surfaces, then the stable is too closed off for proper ventilation.

Horse owners often want warm stable conditions for their comfort during horse care activities. Instead of heating the whole barn or cutting off ventilation to trap horse body heat, provide a heated grooming and tacking area. If freezing conditions cannot be tolerated, then supplemental heat will be needed in susceptible areas, such as the tack room or washing and grooming areas. Frost-proof, self-draining hydrants (Figure 2) and freeze-proof automatic waterers are available. Water pipes within the stable need to be buried to the same depth as supply plumbing to the stable site.

### *What about drafts?*

A draft occurs when cold air blows on a horse. Warm air blowing over a horse is not a draft. Since horses tolerate colder conditions than humans, what we consider drafty is not necessarily uncomfortable to the horse. Be sure to differentiate between cold temperature and draft. A main principle of ventilation is that even very cold fresh air can be introduced into a horse stall, so when mixed and tempered with stable air, it no longer has the air speed and chill of a draft.

**Figure 2. Design detail for freezing conditions, such as this self-draining water hydrant, will be needed in most horse stables.**



### What about air distribution within the stable?

An open, unobstructed interior helps move air around the stable. Provide airflow between the openings in the stable where fresh air enters and stale air exits. Fresh air is brought into the horse stalls where it picks up moisture, heat, dust, and ammonia and

An open, unobstructed interior gets fresh air to the horses and provides an exit path for stale air.

can exit out another opening. Stuffy stables, and their poor air quality, are the product of limited air exchange and/or obstructions to getting the fresh air to where the horses are stalled.

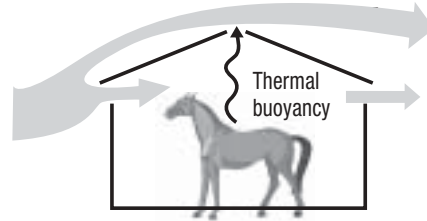
Go into the horse stall to determine the air quality of the stable. Moisture, odor, and ammonia are generated primarily in the stalls, where fresh air is needed for horse respiration and to dilute air contaminants. Since most dust and ammonia are down near the bedding and manure, check air quality near the floor as well as at horse-head height. Floor-level air quality is particularly important for foals or when horses eat at ground level and spend time laying in the stall. It is not uncommon for the stable's working aisle to be breezy and well ventilated while the stalls suffer from stuffy conditions.

### How much ventilation should be provided?

Natural ventilation is often expressed in "air changes per hour." An air change per hour (ACH) means that the total volume of air in the stable is replaced in an hour's time. Six air changes per hour means a complete air change every 10 minutes. Provide 4 to 8 air changes per hour to reduce mold spore contamination, minimize condensation, and reduce moisture, odor, and ammonia accumulation. For comparison, the modern home

has 1/2 air changes per hour from infiltration through various cracks, such as around doors and windows. This recommendation for stable ventilation is substantially more than the average residential air exchange rate to maintain fresh air conditions and good air quality in the more challenging stable environment.

**Figure 3. Horse stable ventilation uses architecture with openings along sidewalls and ridge to accommodate the two forces behind natural ventilation: thermal buoyancy and wind.**



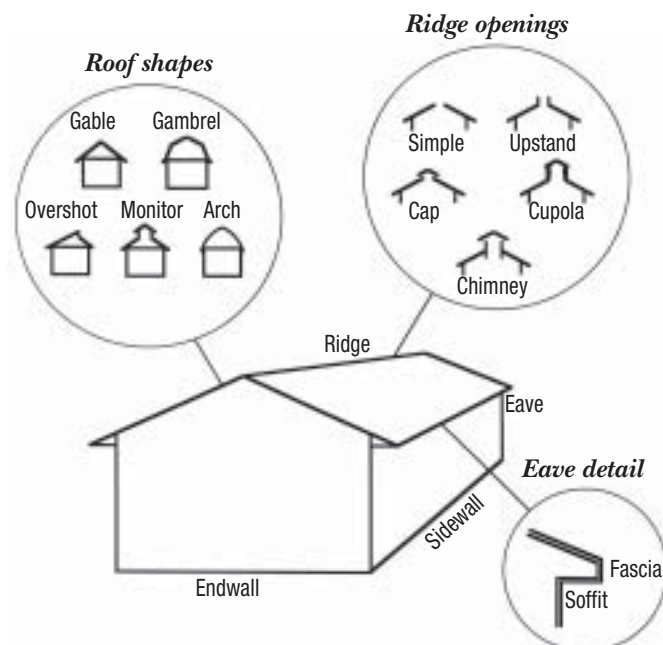
### How is ventilation provided to the structure?

Natural ventilation is used in horse stables and riding arenas. Wind and thermal buoyancy (hot air rises) are the natural forces that drive this type of ventilation (Figure 3). Natural ventilation uses openings located along the sidewall and ridge (roof peak) to accommodate these air movement forces. (Figure 4 shows building terminology used in this publication.)

The sidewall openings are more important than the ridge openings if stable design cannot accommodate both sets of openings. The stable ventilation system will work better when both ridge and sidewall openings are provided. The ridge opening allows warm and moist air, which accumulates near the roof peak, to escape. The ridge opening is also a very effective mechanism for wind-driven air exchange since wind moves faster higher off the ground.

Go into the horse stall to determine the air quality of a stable.

**Figure 4. Building terminology used for describing ventilation system design and functions.**



Wind is the dominant force in horse stable natural ventilation. With the variability in wind speed and direction, openings on the stable will frequently alternate between being an inlet for fresh air and an outlet for stale air. Wind will push air into the stable through openings on the windward side of the building while drawing air out of the stable on the leeward, or downwind, side. Once the wind speed is above about 1 mph, wind-driven ventilation will dissipate the effects of thermal buoyancy in horse stables.

Since horse stables are typically unheated, they are considered “cold” housing. Thermal buoyancy (hot air rises) is dependent upon a temperature difference between the warmer stable interior, where the horses’ body heat will slightly warm the surroundings, and the cooler outside conditions. Because a properly ventilated stable has less than a 10°F difference between the stable interior and outside conditions, there is not a large temperature difference as a driving force for buoyant air movement.

### What about using fans?

The other major type of ventilation is mechanical ventilation, which uses fans, inlets, and controls in a pressure-controlled structure. Mechanical ventilation is typical in some types of livestock housing (poultry and swine) but is not commonly needed in horse stables. Natural ventilation is adequate for housing animals, such as horses and cattle, that are tolerant of a wide range of temperature conditions. Mechanical ventilation is more expensive to install and maintain but offers control over the air exchange rate. Heated stables may employ mechanical ventilation during the heating season. The fan(s) has a known capacity in cubic feet per minute (cfm) and provides a uniform air exchange rate. Minimum recommendations for each 1,000-pound

horse are 25 cfm for moisture control in cold weather; 100 cfm for heat removal during mild weather; or 200 to 350 cfm during hot weather. Inlets are sized at 1.7 ft<sup>2</sup>/1,000 cfm of fan capacity.

Circulation fans may be used in stables for temporary relief to disrupt warm, stale areas or to provide a cooling breeze over the horse’s body. These fans move air already in the stable so they do not provide more fresh air to the horse. A properly designed stable ventilation system should virtually eliminate the need for circulation fans.

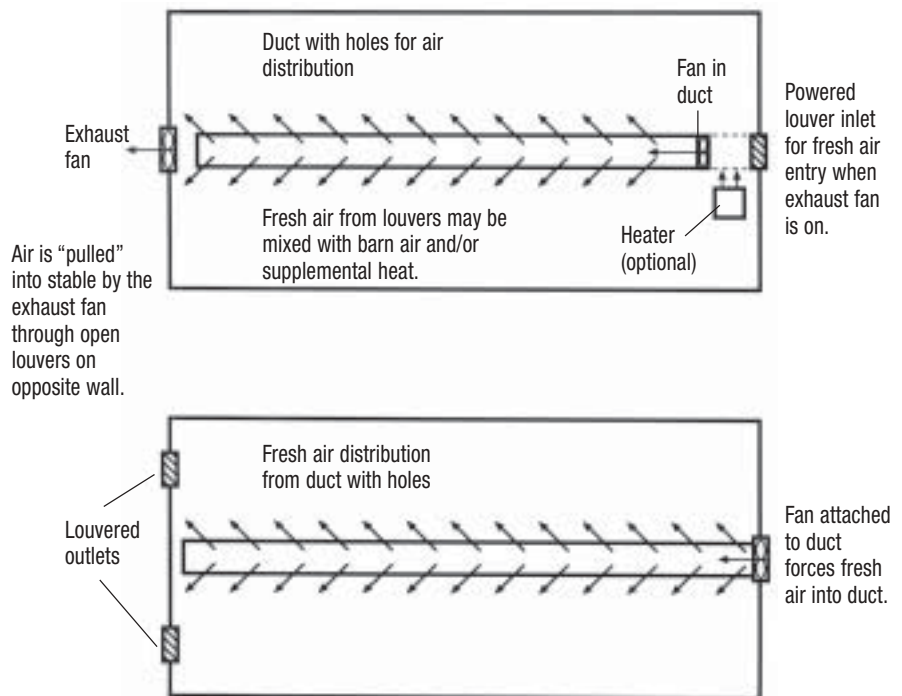
Another application of mechanical ventilation uses a fan blowing air

into a duct to distribute fresh air throughout a part of a stable where direct access to outside air is difficult (Figure 5). This duct system can be used in retrofitting older barns and is particularly effective in the underground portions of bank barns where access to fresh air is limited. Ducts can also effectively distribute supplemental heat in a barn.

Each stall should have direct access to fresh air openings that are open year-round.

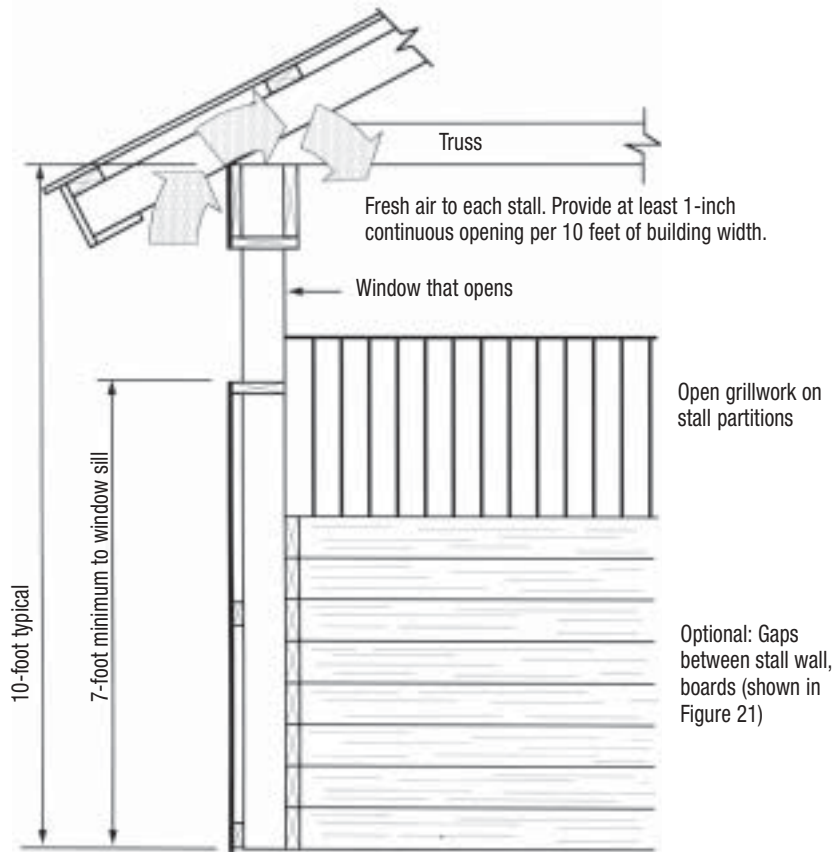
**Figure 5. Overhead view of two mechanical ventilation systems with fan and duct used to distribute air.**

Top diagram shows distribution duct for a combination of fresh, heated, and/or recirculated air. Exhaust fan system draws air into stable through louvered inlet on one wall and discharges stale air on the opposite wall. Bottom diagram shows fresh air distribution with no recirculation. Louvered outlets provide stale air exit.

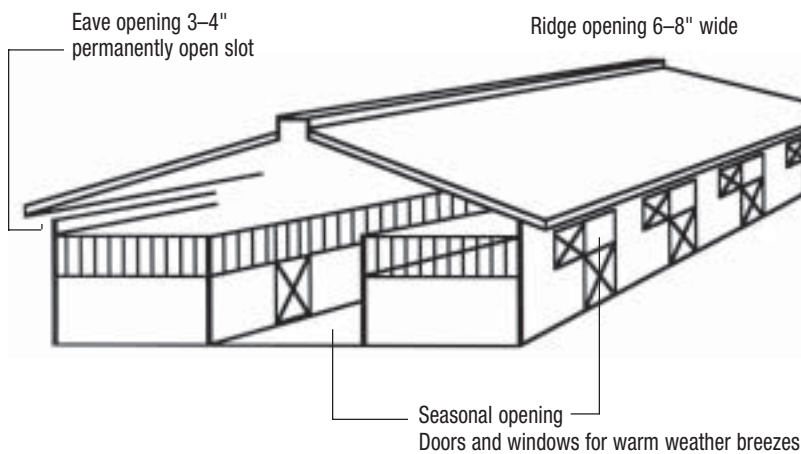




**Figure 6.** The best way to provide draft-free fresh air to each horse stall is through an opening at the eave. Figure shows a cut-away view of stall components and eave opening. The eave is open year-round with additional, large warm weather openings provided by opening windows and doors.



**Figure 7.** Perspective view of ventilation openings on a central-aisle stable. Eave inlet slot runs entire length of sidewall. Ridge vent shown has simple opening with upstand.



## Recommendations for Providing Effective Natural Ventilation

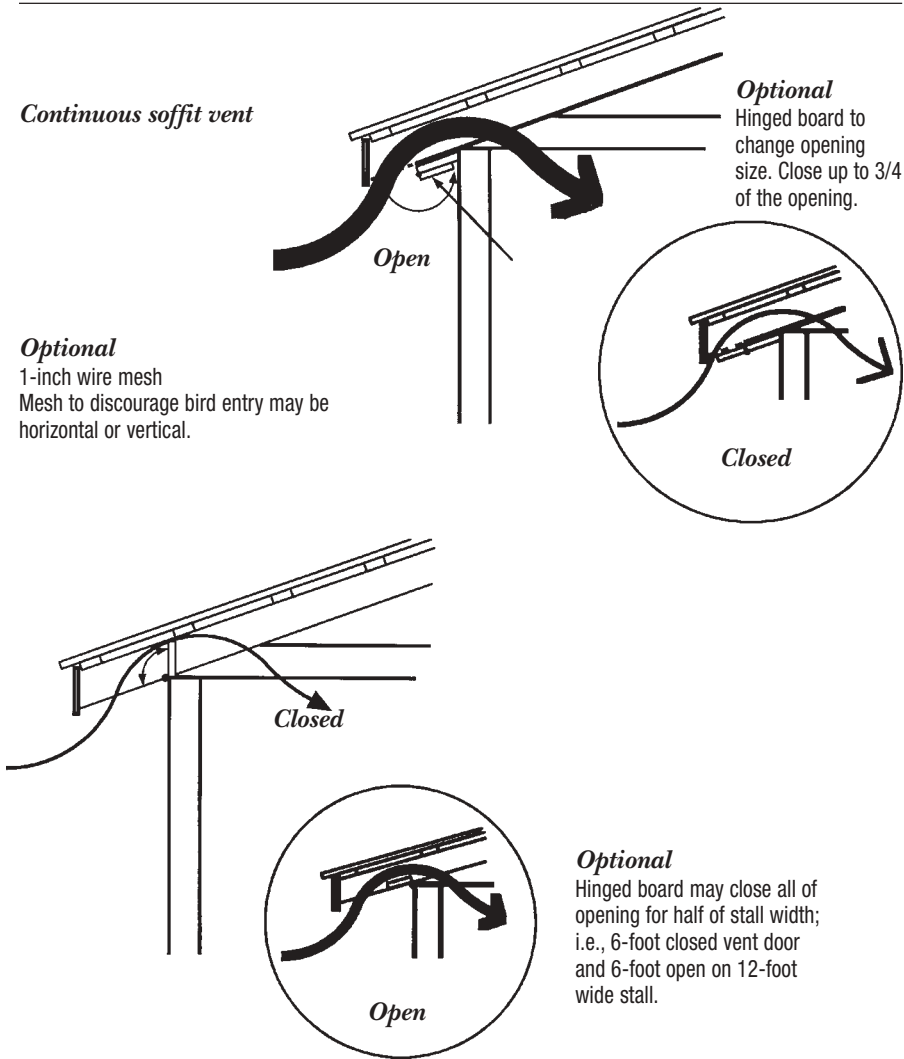
### Permanent Openings

Furnish stalls with some sidewall openings that are permanently open year-round. Each stall should have direct access to fresh air openings. A guideline is to supply each stabled horse the equivalent of at least 1 square foot of opening into its stall to allow ventilation even during the coldest weather. The best location for this permanent opening is at the eave (where sidewall meets roof). A slot opening along the eave that runs the entire length of the stable is often used (Figures 6 and 7).

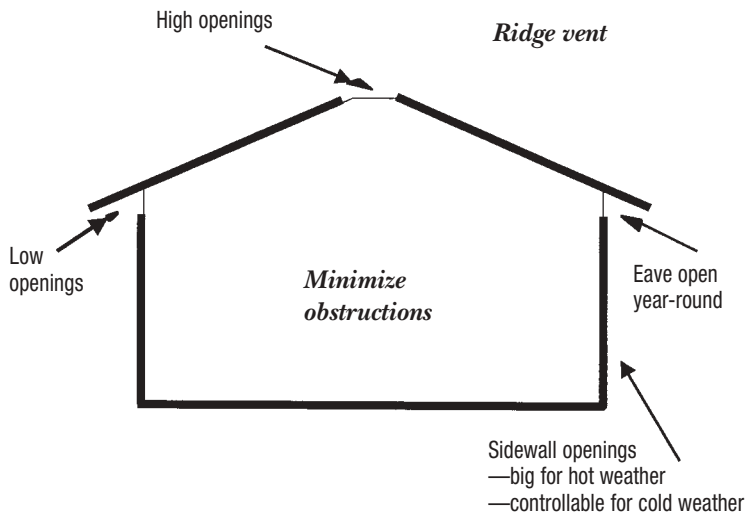
There are several benefits of a continuous slot opening at the eaves. The slot opening provides equal distribution of fresh air down the length and on both sides of the stable, providing every stall with fresh air. The opening's position at the eave, 10 to 12 feet above the floor, allows the incoming cold air to be mixed and tempered a bit with stable air before reaching the horse. The long slot inlet is desirable during cold weather since air enters the stable through a relatively narrow opening as a thin sheet of cold, fresh air rather than as a large, drafty mass of air provided by an open window or door.

A minimum guideline for cold climates is to provide at least 1 inch of continuous-slot, permanent opening for each 10 feet of building width. For a 12-foot-wide stall, a 1-inch-wide continuous slot will supply 144 square inches, or 1 square foot, of permanent opening. One functional and recommended design, shown in Figure 7, incorporates 3 to 4 inches of permanent opening at the eave on each sidewall of a center aisle stable (36 feet wide). This is slightly above the minimum recommendation and works well to ensure a well-ventilated stable during cold and cool condi-

**Figure 8. Options for eave inlet openings.**



**Figure 9. Natural ventilation construction features include high and low openings, some of which are open year-round. Larger openings provide hot weather air movement.**



tions when other stable openings are often kept closed. Some stables have larger permanent openings, sporting 13-inch eave vent openings on 16-inch eave overhangs plus a 6-inch opening at the ridge. These vents are open all year.

Other stables outfit the eave opening with a hinged panel so that the opening size may be partially closed during extreme cold weather (Figure 8). It is open the full 6 inches all summer and reduced to a 2-inch slot in the winter by swinging a 1 x 4 board over part of the opening. Do not cover more than 75% of the eave opening and only do so during severe weather. In foaling stalls, in moderate climates, a 2-inch by 7-foot-long slot may be installed about 20 inches above the floor to guarantee fresh air at foal level. This gets the foal off to a good start.

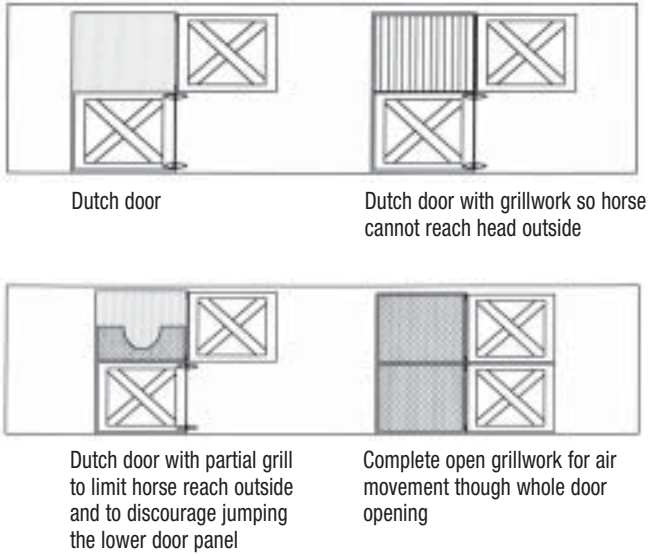
**Seasonal Openings**

In addition to the permanent openings for cold weather, another set of large openings allow cooling breezes to enter the stable during warmer weather (Figure 9). Stables with interior central aisles have large endwall doors that are opened for this function. When horses are kept indoors during warm weather, allow breezes to enter the horse stall with windows or doors that open from the stall to the outside (Figure 10). Provide openings equivalent to at least 5 to 10% of the floor area in each stall. For a 12-foot x 12-foot box stall, sufficient openings would be a 3 x 2 1/2 foot open window for 5% opening or 4 x 3 1/2 foot open window (or top of Dutch door) for 10% opening.

**Stable Ventilation Openings**

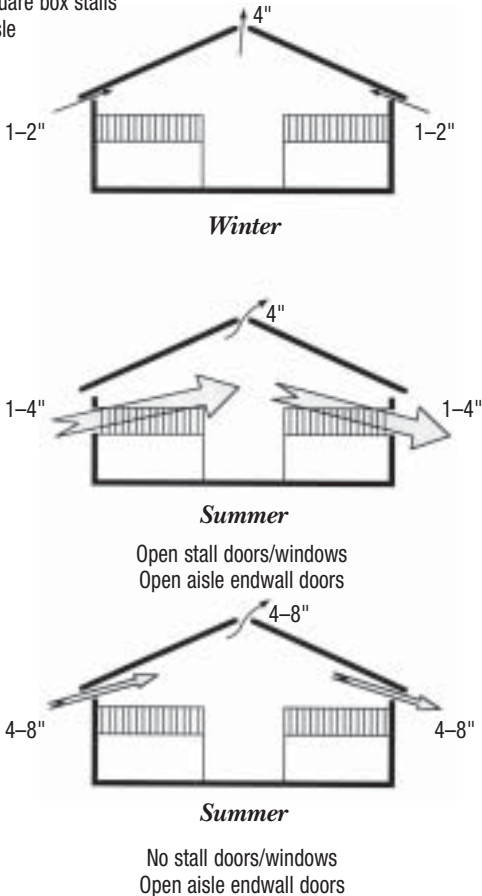
Figures 11, 12, and 13 provide recommendations for the minimum acceptable cold weather openings and warm weather options. Greater openings at the eaves, except for the coldest days, are desirable to assure good air quality within the stable during

**Figure 10. Options on exterior stall doors to provide warm weather ventilation openings.**



**Figure 11. Recommended ridge and eave openings for center aisle stable with stalls on both sides.**

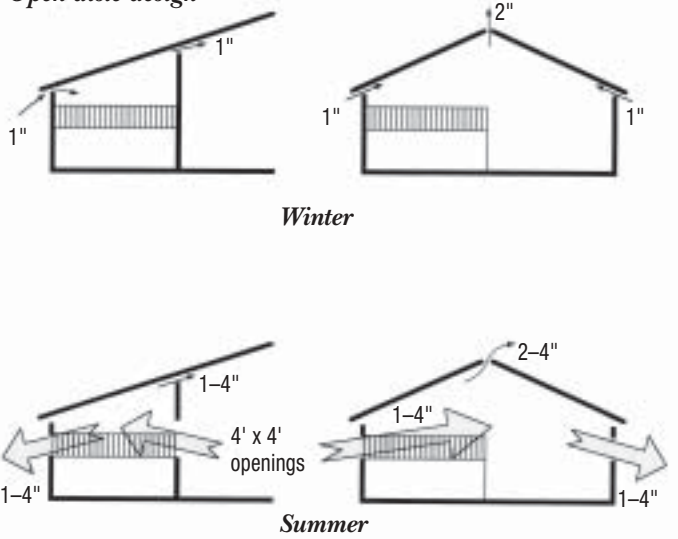
Eave and Ridge Natural Ventilation—minimum opening sizes  
 12-foot square box stalls  
 12-foot aisle



**Figure 12. Recommended ridge and eave openings for single aisle stable with stalls facing an outside work aisle.**

Eave and Ridge Natural Ventilation—minimum opening sizes  
 12-foot square box stalls  
 10-foot aisle

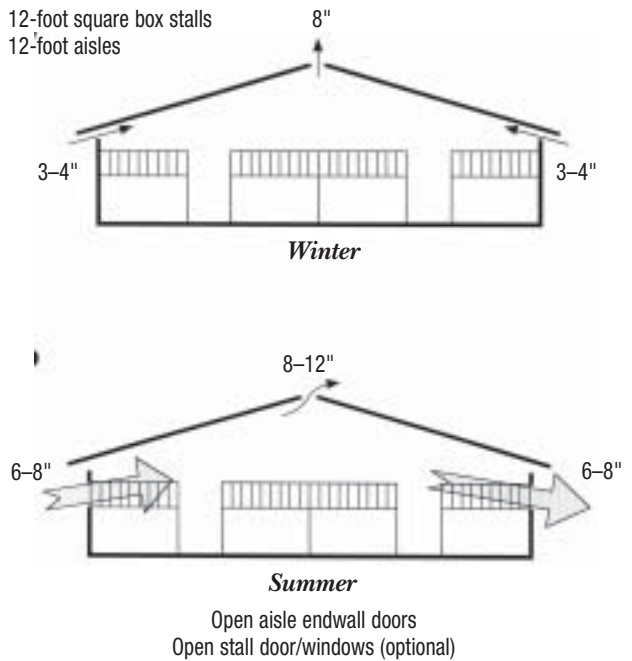
*Open aisle design*



Open stall window/door on front    Open aisle endwall doors  
 Open stall window on back (optional)    Open stall and aisle windows

**Figure 13. Recommended ridge and eave openings for double aisle stable with four rows of horse stalls across width. The central stalls in the four-row layout will get almost no fresh air since they are not near a fresh air opening.**

Eave and Ridge Natural Ventilation—minimum opening sizes  
 12-foot square box stalls  
 12-foot aisles



cold and cool weather. If sufficient ridge vent is not provided, then double the eave vent opening sizes. Center aisle (Figure 11) and single aisle (Figure 12) stables are easy to properly ventilate.

The recommended ventilation openings for a double-aisle stable, with four rows of horse stalls across width (Figure 13), attempt to overcome shortcomings of this building design. The central stalls in the four-row layout will get almost no fresh air since they are not near a fresh air opening. Ventilation in these central stalls will be particularly compromised if stall walls are solid without grillwork on the top portion. With solid stall walls and a ceiling over the central stalls (for storage), there will be no fresh air movement into those stalls. This double-aisle layout is not recommended when horses will be kept inside more time than turned out. Daily stall cleanout will be important to keep ammonia and odors from accumulating in the central stalls. It is particularly important that this building design contain an open interior (no ceiling and open grillwork on stall walls) so that fresh air can move freely. Similar improper airflow is seen in stables that share a common sidewall with indoor riding arenas. The horses near the arena sidewall will have no access to fresh air unless openings are provided on that side of the stable.

### Avoid Restrictions to Airflow

The permanently open sidewall eave openings should be constructed to be as open as possible. Ideally, they are left completely open. Do NOT cover with residential window insect screening or metal soffit treatments. Both these coverings severely restrict desirable airflow and will soon clog with dust and chaff, eventually eliminating almost all airflow (Figure 14). Metal-sided buildings are commonly finished with metal fascia and soffit


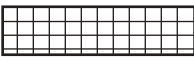
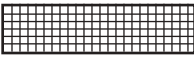



so tell your builder that you need the ventilation air exchange at the eaves and leave off the soffit metal. The perforated metal soffit was designed for residential and commercial attic ventilation applications where the need is about one-third of even the minimum airflow for horse stables. Residential soffit has very tiny holes to exclude large insect entry, but will clog with dirt and dust within months if installed in a horse stable. In addition, attics are almost dust-free compared to horse stables. To discourage bird entry at the eaves, wire mesh squares of approximately  $\frac{3}{4}$  to 1 inch may be installed. Since birds will enter the facility through larger openings such as doors and windows, wire mesh on the eaves is not necessary. Similar logic applies to fly entry.

### Ridge Vent

Ridge opening area should match the eave opening area with a minimum of 1 square foot of opening per horse. The same recommendation for the eaves (providing at least 1 inch of continuous slot opening per 10 feet of building width) applies to the ridge opening. If no ridge opening is provided, then supply double the minimum recommended eave opening (supply 2 inches of continuous eave opening per 10 feet of stable width if no ridge vent is used). Similar to cautions raised about eave openings, be sure to avoid residential and commercial ridge vent assemblies that are overly restrictive to air movement. Insect screens restrict airflow. Remember, you are ventilating a barn not a house attic—not only is

**Figure 14. Open area and effective area for ventilation through eave inlet treatments.**

Note: Some soffit coverings are so restrictive to airflow that greatly increased soffit area is needed to provide 1 square foot of inlet area per stall. Tight screenings and small holes will clog with dust within months of installation, providing almost no airflow through opening.

Open area	Diagram	Description	To provide 1 square foot of opening	Effective area
100%		Simple opening	1 sq ft	Recommended. Full area allows airflow.
87–94%		Opening covered with 1" square wire mesh or poly bird netting with 3/4 x 1 1/8" openings	1 to 1.1 sq ft	Recommended. Slight but acceptable restriction to air moving through mesh.
80–84%		Opening covered with 2 x 2 mesh hardware cloth with 1/2" openings	1.25 to 1.5 sq ft	Potential for chaff; insects and freezing condensate to clog the openings.
66%		Residential insect screening 18 x 16 mesh per sq in with 0.05" holes	2.5 to 3 sq ft	NOT recommended. Too restrictive to airflow and small holes will clog with dust.
43%		Under eave louver or slotted soffit with 1/8 to 5/16" slots	2.5 to 3 sq ft	Restrictive to airflow and often includes an insect screen, which will clog with dust
4–6%		Soffit vented with 1/8" punched holes	16 to 25 sq ft	NOT recommended. Designed for house attic insect exclusion. Provides almost no airflow and will clog with dust within months.



more air exchange needed, but also the stable dust will clog small screen openings. Ridge vent assemblies from natural ventilation equipment manufacturers that specialize in agricultural buildings will offer relatively

unrestricted airflow with modest protection from precipitation. Figure 15 shows several commercially available ridge vent assemblies. Some are useful in horse stable ventilation, while others restrict natural ventilation air-

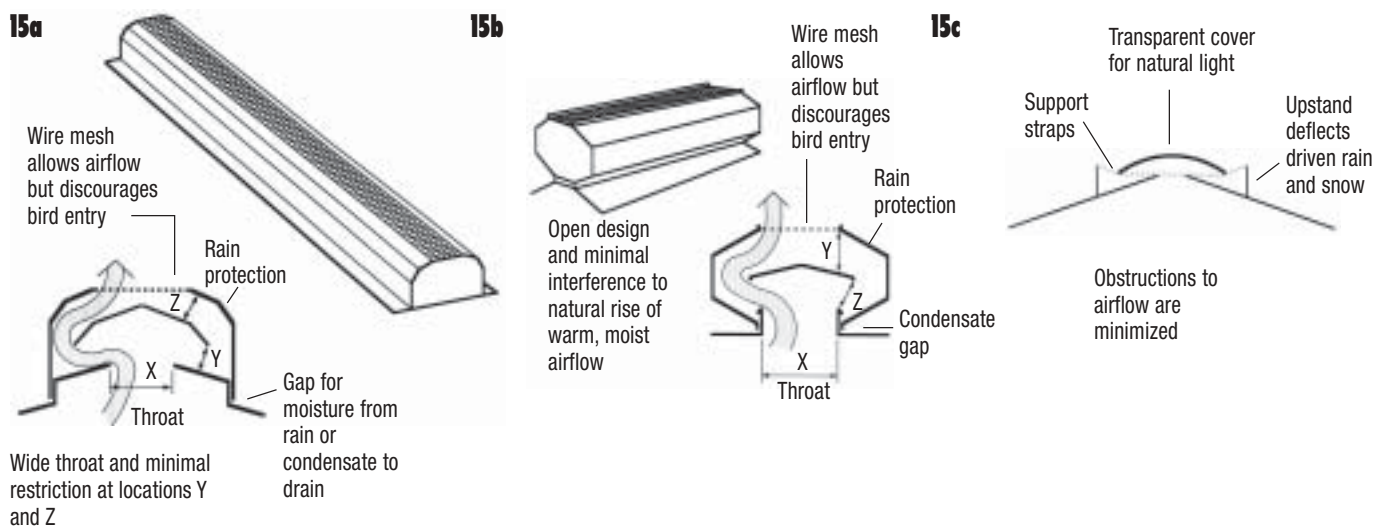
flow. Several ridge vent designs incorporate transparent or translucent materials to allow natural light entry into the stable.

The actual ridge opening is measured at the most restrictive part of

### Figure 15. Examples of manufactured ridge vent construction showing opening sizes and air flow path.

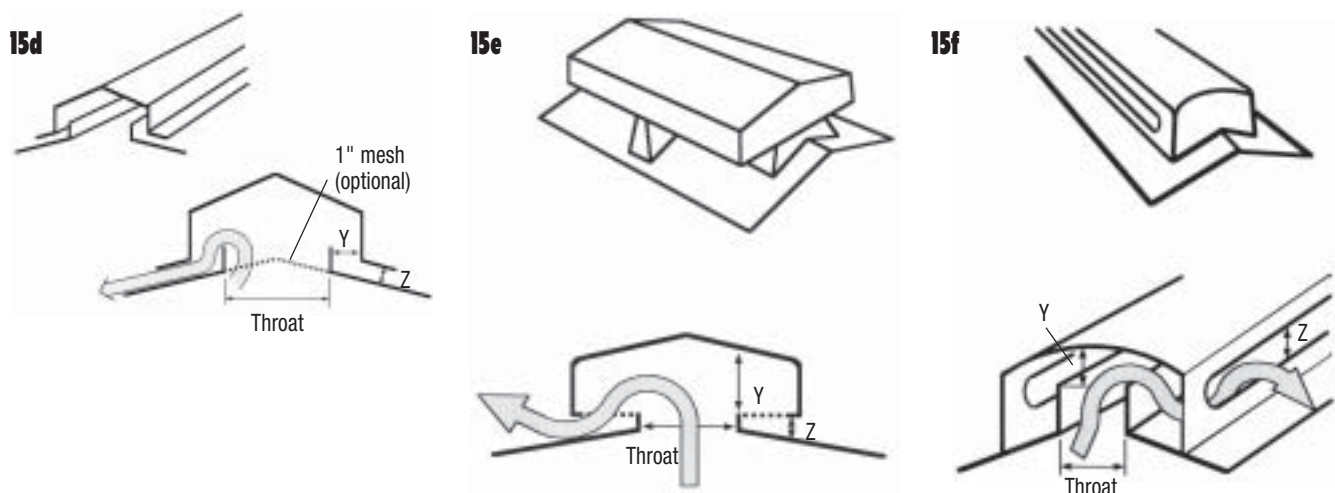
The narrowest part of the airflow path, at location-Z, will influence air movement. Agricultural ridge vent assemblies (15a, b, and c) may be used in horse stables. Some commercial/industrial building ridge vent assemblies may be used on horse stables (15d, e, and f), although they are moderately disruptive to natural ventilation air movement. Residential ridge vents are not recommended (and not shown here) since they do not provide enough opening for horse stable ventilation and are prone to condensation, freezing the opening shut.

#### Attributes of good ridge vents for horse stables.



#### Attributes of less desirable ridge vents for horse stables.

Air rises at ridge so not inclined to go down to exit ridge assembly  
Severe vent restriction at Z versus wide throat clearance



the ridge vent assembly. Manufacturers often supply the throat opening where the bottom of the ridge vent attaches to the building interior, but the key measurement for air movement is where the airflow path is narrowest. This narrowest restriction is shown at location “Z” of the vent assemblies of Figure 15. Some of these designs (particularly d and e) prevent warm, moist air from naturally flowing upward and out of the building ridge vent when no wind is blowing. Warm, moist air flows up and is not

inclined to move downward to get out of the ridge vent assembly. This air trapped in the ridge vent will not only block ventilation but may condense, leading to dripping or freezing during cold weather. The simplest and most effective ridge vent is an unprotected opening at the ridge (Figure 16). The building trusses or rafters are protected from precipitation and the stable interior is managed so that occasional rain entry is tolerated. Figure 16f shows a ridge opening with an upstand, vertical boards on each

side of the opening that increase air movement through the ridge opening.

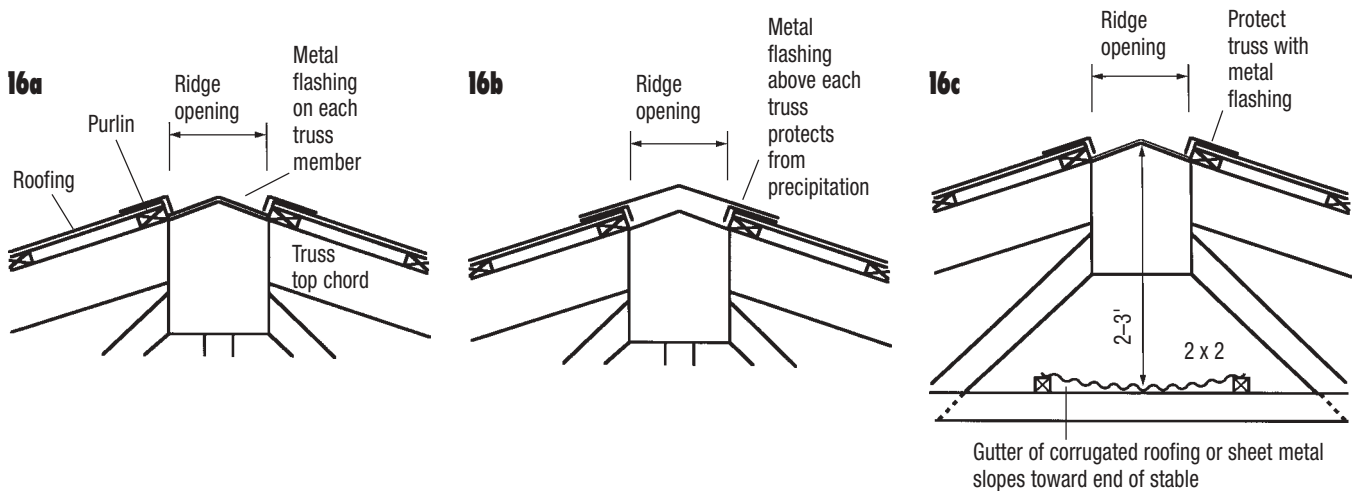
The ridge vent can be a continuous opening or a series of intermittent vent assemblies spaced uniformly along the structure. During winter, a portion of the vents can be closed to provide only the recommended permanent opening area, while all the vents are opened during warmer weather when more air exchange is needed.

**Figure 16. The simplest and most effective ridge opening is an unprotected opening. Six design options are shown.**

From *Natural Ventilating Systems for Livestock Housing*. MWPS-33. MidWest Plan Service, Ames, Iowa. 1989.

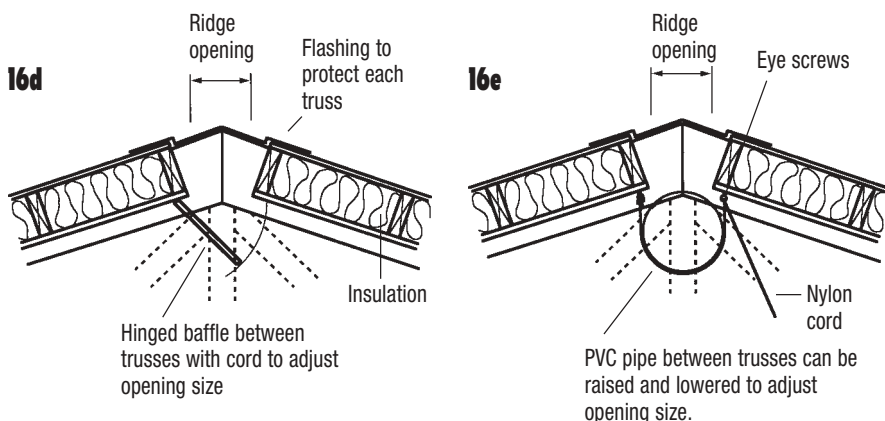
**Simple ridge opening**

Add flashing on (a) or above (b) exposed truss members

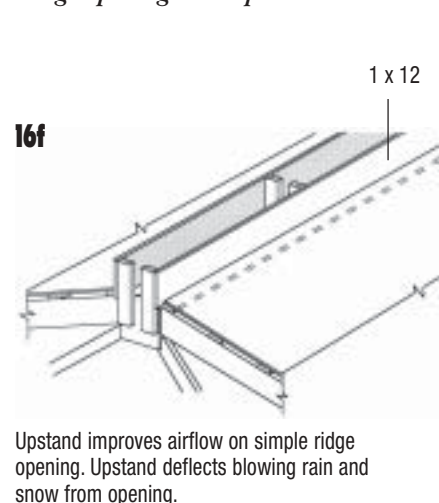


**Adjustable ridge openings**

A hinged baffle or pipe is raised and lowered. Adjustable ridge is useful on heated barns to regulate ventilation rate.



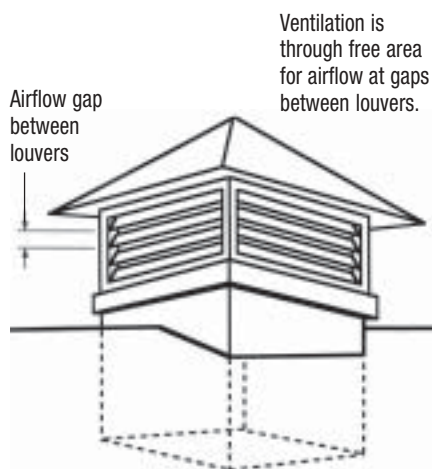
**Ridge opening with upstand**



### Ridge Opening Options

The ridge vent does not have to be a continuous opening, although this offers the most benefit in uniform air quality within the stable. Cupolas are a popular architectural feature in many stables and they can be used as a ridge opening (Figure 17). Measure the open area at the most restrictive construction of the cupola, which is often at the louvers. A cupola may have a 3-foot-square opening into the stable area that offers 9 square feet of ventilation opening, but make sure that the louvers above this opening also have at least 9 square feet of effective open area. Louvers commonly block 50% of the open area they are protecting. Be aware that some cupolas are purely decorative and have no way for stable air to move through them. For visual balance of the cupola with the stable size, provide about 1 inch of cupola width for every foot of roof length. Most cupolas are square in width at the opening to the stable and taller than wide. For

**Figure 17. Cupolas are a popular horse stable design feature and can provide ridge ventilation if sufficient louvered openings are provided. Ridge vent assemblies that are made for livestock building ventilation are a good option for unrestricted airflow.**



Opening into stable interior is often much larger than total gap areas at louvers. Smallest area (at louver gaps) controls airflow.

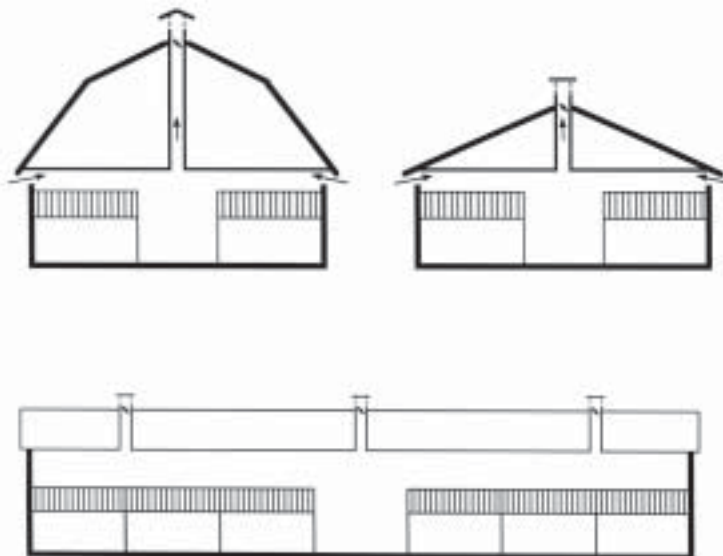
example, a 48-inch-square by 80-inch-tall cupola will look properly proportioned on top of a 30- to 36-foot-wide by 40- to 60-foot-long stable.

In stables with a ceiling, chimneys are a popular construction for moving air from the stable area and exhausting it at the roof peak (Figure 18). The vertical duct of the chimney travels through the roof or upper story of the stable (attic or hay mow). When chimneys run through an attic or mow, insulate the chimney walls to R-10 to discourage condensation as the relatively warm stable air is ducted through the cold areas. The chimney exit must extend at least 1 foot above the building peak (i.e., stable air is not discharged into the attic or mow).

Sizing of the cupola and chimney opening is the same as for continuous ridge vent (at least 1 square foot of opening per horse housed) with additional chimney requirements for proper airflow being no smaller than 2 x 2 feet for one-story buildings and 4 x 4 feet for two-story buildings. On a long stable, it is better to provide more than one cupola or chimney at approximately 50-foot intervals.

**Figure 18. Chimneys are useful as the high opening on stables with ceilings.**

Provide chimney opening equivalent to  $\frac{1}{2}$  to 1% of stable floor area with a 2-foot-square minimum chimney size for one-story buildings and 4-foot-square minimum for two-story buildings. A damper, controlled via cable from below, is useful in cold climates. The damper with 90% closure is located near the top of the chimney to keep the shaft charged with warm air for more controlled airflow.



### Condensation and Insulation

Condensation occurs when moisture is released from air as it cools in contact with a cold surface. Insulation is used to keep potentially cold surfaces near the interior building temperature, reducing condensation. Unheated barns need R-5 insulation at the roof to discourage condensation on roof steel, even under well-ventilated stable conditions. Condensation not only leads to annoying dripping but also shortens the life of metal and wood roof materials. Shingle roofs over plywood construction provide an insulation level near R-2. A 1-inch thickness of polystyrene provides R-5 insulation value and is resistant to moisture absorption. Polystyrene also has good vapor barrier properties, although each rigid board joint needs to be sealed against moisture movement.

Avoid screening cupolas or chimney openings for anything smaller than bird entry (approximately 1-inch-square wire mesh).

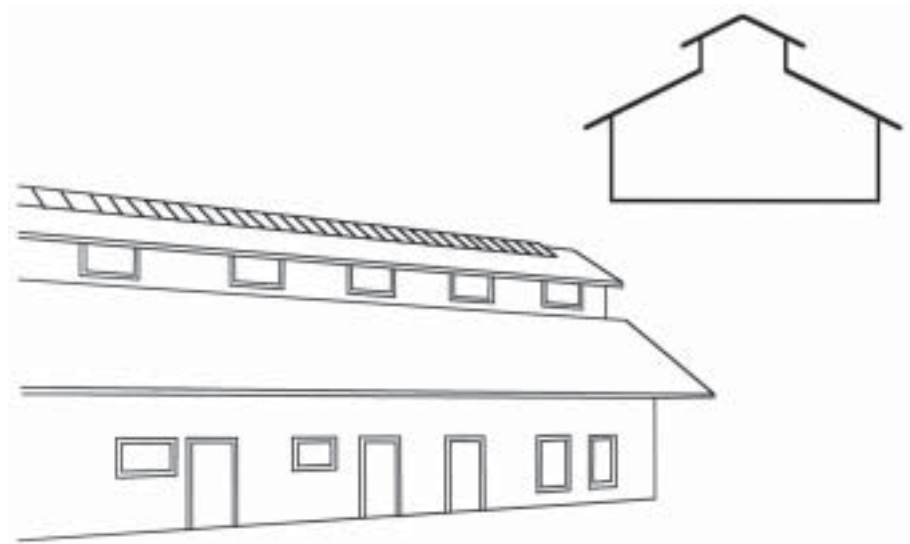
A monitor roof (Figure 19) offers high openings at windows that open near the peak. Vent area can also be provided along the soffit at the eaves of the monitor section. Light from the windows along the monitor roof is another benefit of this roof design.

### *The Breathable Wall*

An additional way to allow fresh air exchange in a stable is the breathable wall concept. With barn board siding there are miles of small cracks between the boards that allow a bit of air movement at each juncture (Figure 20). This is known as a breathable wall. Battens added to the boards will reduce this effect as will tongue and groove siding. Modern construction with large 4 by 8 foot (and larger) panels have eliminated the breathable wall via eliminating the cracks (large panel construction requires eave and ridge vent to replace the crack openings). Taking a look at an older barn, much of its informal ventilation was through the airy nature of the breathable wall provided by the barn siding. The air coming in the cracks is nicely uniform throughout the structure and by being such a tiny air jet, is quickly dissipated, thereby not becoming drafty.

Comfortable and uniform fresh air conditions can be maintained within the stable even under windy conditions. Some stables are still built with this deliberate breathable wall concept. The vertical barn boards are spaced  $\frac{1}{4}$  to 1 inch from each other in good construction practice. Rough-cut green lumber may be attached as siding. Once dry, gaps will provide diffuse ventilation. From the stable exterior, the breathable wall siding looks solid and well constructed. From the stable interior, sunlight can be seen penetrating between the boards indicating that air can enter.

**Figure 19. Monitor roof design offers high openings via soffit vent and/or windows that open near the roof peak.**



**Figure 20. Stable interior showing airflow gaps of the breathable wall siding at end of stable aisle. This stable has other good ventilation features including eave and ridge vents, a window that opens for each stall, open grillwork on stall partitions, and no overhead airflow obstructions.**





## Three Design Features to Improve Horse Stall Ventilation

Remember, the objective of ventilation is to get fresh air to the horse. Getting fresh air into the stable is the first important step for good ventilation; next is distributing this air to the stall occupants. Air distribution within the stable is improved by an open, airy interior. The horse stalls provide obstruction to getting air to where the horse is, but a solidly built stall is necessary for safe confinement of the horse.

### Open Stall Partitions

Ventilation air movement is greatly improved by providing openings for air to flow in and out of the stall (Figure 21). Open grillwork on the top portion of front and side stall partitions is highly recommended versus solid stall partitions. Open partitions provide benefits beyond the obvious improvement in ventilation. Open partitions allow horses to see each other for companionship, which is important for this social animal. Open partitions improve management by allowing the caretaker to see horses from most anywhere in the stable. Horses are less prone to be bored and develop bad habits in a stable with open partitions since they can see other horses and stable activities. A horse in a stall with limited visibility of stablemates and activities is in virtual solitary confinement.

Admittedly, some horses are a hazard to their neighbors. A reason to provide solid sidewall partitions is to decrease bickering between horses in adjacent stalls. One option is to provide open grillwork throughout the stable but cover the grillwork partition with a panel (i.e., plywood or spaced boards for more air movement) for unneighborly horses.

With solid sidewalls, the front stall wall becomes more important for stall ventilation. Provide openings for air movement into the stall with 1-inch gaps between boards in the solid lower portion of the stall wall and/or a full-length wire mesh stall door. The mesh stall door is particularly effective in providing air movement to the stall interior.

For isolation stalls and specialized buildings, such as veterinary practices and some high-traffic breeding facilities, solid washable partitions between stalls may be desirable. Solid walls will limit air distribution around the stable interior. Provide fresh air access in each stall and an airflow path for stale air removal. A mechanical ventilation system with fan and

### Improve Horse Stall Ventilation

Unobstructed airflow and air quality are improved by:

1. Open grillwork on top of front and side stall partitions
2. No ceiling with interior open to roof peak

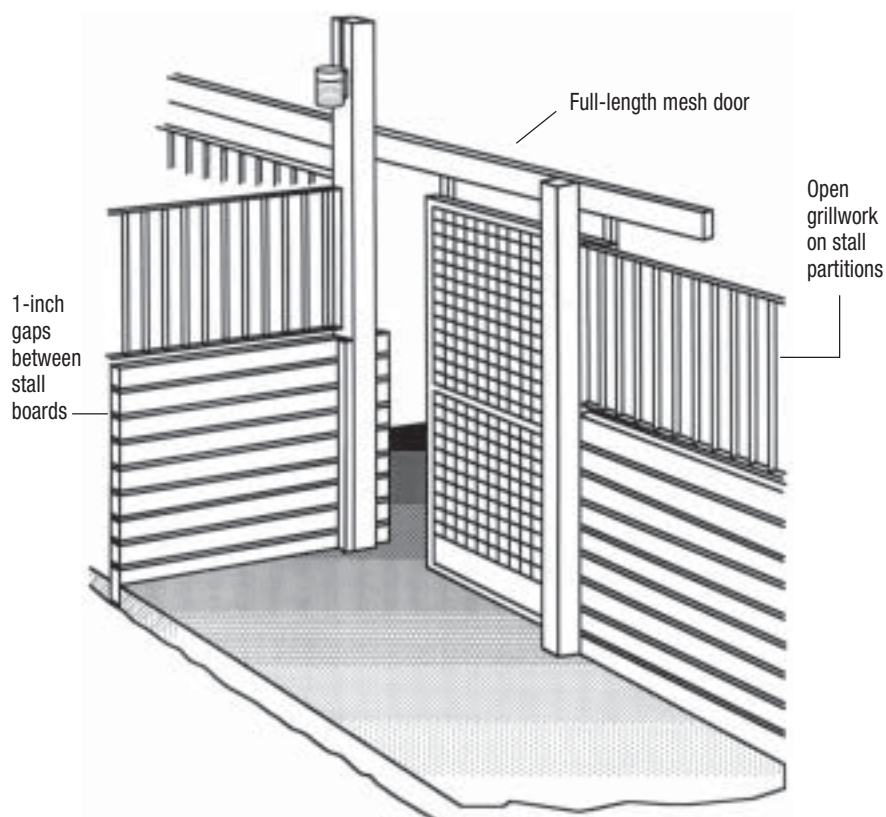
Compromise: High ceiling at 12 feet minimum

3. No overhead hay-bedding storage

Compromise: No storage over horse stalls

**Figure 21. Features that improve air movement into and out of the horse stall include gaps between partition boards, open grillwork on upper portions of stall partitions, and door with full-length open grillwork.**

Adapted from Horse Housing and Equipment Handbook, MWPS-15. MidWest Plan Service, Ames, Iowa. 1971.



ducted air can be used to control air exchange and to limit air mixing with the rest of the stable environment. In most applications, the natural ventilation principles using fresh air openings for each stall and ridge vent should be sufficient.

### *No Ceiling*

When the interior has no ceiling and is open to the roof peak (and ridge opening), more air exchange and distribution can occur. If a ceiling must be used in a stable, position it no less than 12 feet above the floor to allow air circulation (Figure 22). Stables with ceilings, and particularly low ceilings, appear more confined and are darker than an open, airy structure.

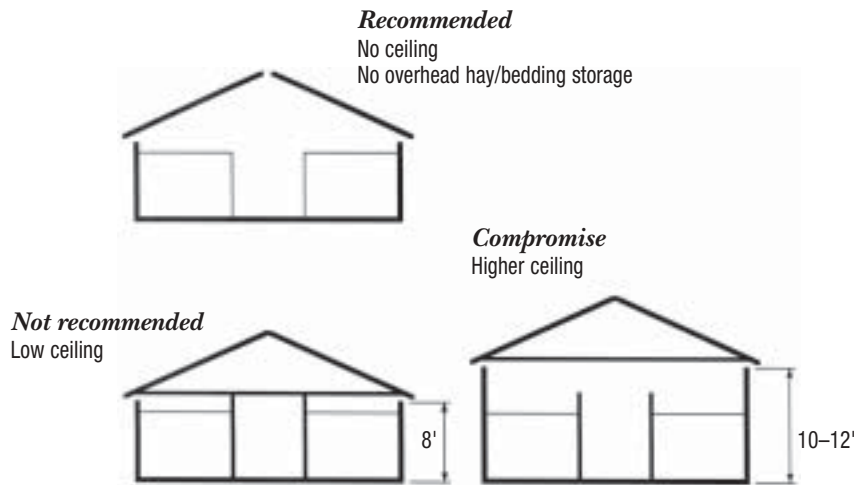
### *No Overhead Hay/Bedding Storage*

To improve air quality and distribution, do not incorporate overhead hay and bedding storage in the stable. If hay and bedding must be stored overhead, construct the storage over the work aisle so that the horse stall has no ceiling for better air circulation (Figure 23). Leave at least 3 feet of clearance between the height of overhead stored items and the roofline to allow an airflow path to the ridge opening. Ridge openings above overhead hay storage should not allow precipitation or condensation to fall onto the forage.

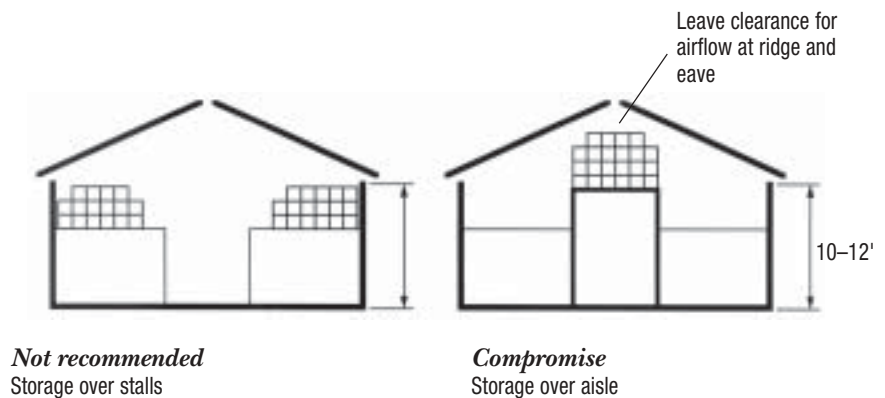
The most often cited reason to eliminate overhead hay-bedding storage is for decreased dust and allergens in the stable. Managers of redesigned stables, where the hay and bedding are now stored in a separate building, provide testimony to the decreased dust irritation. Dust, chaff, and molds rain down on the stalled horses from overhead hay storage.

When the overhead hay storage is completely separated from the horse area with a full ceiling, dust and mold generation is minimized for the horses except when hay bales are be-

**Figure 22. Avoid stable design with low ceilings, which inhibit airflow within the stable.**



**Figure 23. Do not store hay and bedding overhead to increase air movement within the stable and minimize dust and fire hazard. As a compromise, provide storage over the aisle to maximize airflow to the horse stalls.**



ing tossed down. Dust and mold can be somewhat contained in the hay-loft, particularly if trap doors to the stall hay feeders are kept closed except when in use. Recall that full ceilings need to be relatively high to allow proper natural ventilation of the horse stalls.

Stored hay is a spontaneous combustion fire hazard when not properly cured. Unfortunately, the fire hazard from stored hay and bedding is often dismissed. The fire department is rarely able to save the hay/bedding storage structure once ignited. If hay storage is in your stable,

understand the risk. Forage fires are intensely hot and burn at a very fast rate. Fire departments work to contain the fire, but have little chance of putting it out to save the structure.

## Why Inadequate Ventilation?

Two major factors lead to inadequate ventilation in modern stable construction. First, some stable designers are unfamiliar with how much air exchange is needed in a horse stall. Second, horse owners tend to be most comfortable in copying residential building practices. The belief that indoor housing provides a more desirable environment for horses is true only if a well-designed ventilation system is an integral part of the stable.

Very limited information has been available for horse stable builders and designers to refer to when properly designing horse stable ventilation systems. Many of these architects and builders work primarily in the residential and commercial building industry where moisture, odor, and dust loads are much lower than in horse stables. Even when the differences in environment are appreciated, the ventilation system may fail due to a lack of understanding how to get fresh air into each horse's stall. Fewer builders are specializing in agricultural (i.e., horse and other livestock) construction and the environment within these structures. It is better to find an experienced builder who understands horse stable design and ventilation features, but properly supplied with design ideas, inexperienced builders can tackle horse stable construction. With the low animal density of horse stabling (at about 4 lbs of horse per sq. ft) compared to other commercial livestock enterprises (for example, a freestall dairy at 13 pounds of cow per sq. ft) and with horses often being outside a large portion of the day, the stable ventilation system can be a bit forgiving of imperfect design.

Good-intentioned horse owners are the second part of the ventilation problem. Most horses are kept in suburban settings with few horse owners familiar with ventilation performance and benefits. With most horses kept for recreational purposes, the effects of poor ventilation often manifest as chronic but mild respiratory conditions versus the quickly measurable drop in performance seen in other livestock (decreased milk or meat production).

Stable designs often have a distinctly residential flair and may not be suitable for the health of the horse. Air-tight buildings are for people. Horses need a more open environment and are in fact, healthier when kept outside most of the time. Good agricultural builders regret the compromise to proper ventilation at the request of a client who wants the building completely closed tight to warm the building with horse body heat. Other builders are caught between providing proper ventilation openings and the ire of the building owner when a bit of snow or rain blows in. Better to allow a chance for a bit of precipitation to enter the stable during a few moments in a year than a whole season of the barn being too stuffy. The solution to inadequate ventilation is a familiarity with proper ventilation attributes and some experience in well-ventilated facilities to understand the benefits.

## Measuring Ventilation Rate

Measuring a building ventilation rate is quite simple but in practice it is nearly impossible to estimate accurately for naturally ventilated structures, such as horse stables. When the guidelines presented in this bulletin for opening sizes are followed, the stable will ventilate naturally and appropriately. The most challenging weather for naturally ventilated structures is during hot but windless days. Fortunately for horses, there is rela-

**Figure 24. A vane anemometer measures air speed.**

A rough estimate of ventilation rate may be made with inlet air speed multiplied by area of ventilation opening. This instrument also measures relative humidity and temperature so it can also be used to monitor conditions in the stable and horse stalls.

(Instrument source is provided in the Additional Resources).



tively low body heat accumulation in a stable that is equipped with plenty of warm weather ventilation openings. A ridge opening will let the hottest air escape out the top of the building.

A rough estimate of ventilation rate may be made by measuring the velocity of air entering (or leaving) the stable through ventilation openings and multiplying this by the opening size. Air velocity is measured with an anemometer (Figure 24), in feet per minute, and multiplied by the opening area, in square feet, to get ventilation rate in cubic feet per minute (cfm). To calculate the air changes per hour, divide the ventilation rate by the building air volume. The stable volume is the floor square footage multiplied by the average roof (or ceiling) height.

Measure the incoming ventilation air speed at several openings and at several locations on large openings, then average the velocities and multiply by the open area of airflow. With wind variations moving air into and out of the stable, the air speed (and possibly direction) at each ventilation opening is going to be frequently changing as the measurements are made. This variation of conditions is the primary difficulty in accurately estimating a natural ventilation rate.

## Summary

Well-ventilated stables are necessary for horse health and are the hallmark of good management. Modern construction practices and “residential” influences have resulted in inadequate ventilation in many new stables. There is a need to demystify ventilation; the objective is simply to get fresh air to the horse. Ventilation is primarily driven by wind forces, so good ventilation is achieved by allowing wind to bring fresh air into the building, while drawing out stale air. A permanent opening along both eaves that allow air entry into each stall will provide fresh air to each horse. Ridge openings are important for stale, warm, humid air to escape.

Good ventilation is ideally designed into the original stable plans:

- Permanent openings at eaves and ridge for winter moisture removal and summer heat relief. Breathable walls offer diffuse air entry around the stable perimeter.
- Windows and/or doors that open into stalls for warm weather breezes.
- Promote interior airflow and improved air quality with open partitions and no overhead hay storage.

Prepared by Eileen Fabian Wheeler, associate professor of agricultural and biological engineering

## Acknowledgements

Three reviewers offered detailed and helpful recommendations for improvement of the content and clarity of this publication. Thanks to Nancy Diehl, assistant professor of equine science, Robert Graves, professor of agricultural engineering, and Jennifer Smith Zajackowski, senior research technologist in agricultural and biological engineering.

THE PENNSYLVANIA STATE UNIVERSITY  
AGRICULTURAL AND BIOLOGICAL  
ENGINEERING EXTENSION  
246 AGRICULTURAL ENGINEERING BLDG.  
UNIVERSITY PARK, PA 6802  
PHONE: 814-865-7685  
FAX: 814-863-1031  
WEB SITE: [HTTP://WWW.ABE.PSU.EDU/](http://www.abe.psu.edu/)

## Additional Resources

### Fact Sheet

*Horse Barn Ventilation*, 96-031. 1997. Harry Huffman. Ministry of Agriculture, Food and Rural Affairs, Ontario, Canada.  
[www.gov.on.ca/omafra/english/engineer/facts/96-031.htm](http://www.gov.on.ca/omafra/english/engineer/facts/96-031.htm)

### Sources for instruments monitoring air speed, humidity, and temperature.

Product in Figure 24 is called a Kestrel “wind meter,” manufactured by Nielsen-Kellerman.

Suppliers include:  
Nielsen-Kellerman  
104 West 15<sup>th</sup> Street  
Chester, PA 19013  
610-447-1555  
[www.nkhome.com](http://www.nkhome.com)

Tek Supply (Farm Tek)  
1440 Field of Dreams Way  
Dyersville, IA 52040  
1-800 FARMTEC 800 327-6835  
fax: 800-457-8887  
[www.FarmTek.com](http://www.FarmTek.com)

Gempler’s  
100 Countryside Dr.  
P.O. Box 270  
Belleville, WI 53508  
800-382-8473  
[www.gemplers.com](http://www.gemplers.com)

## Reference Book

Good ventilation and respiratory health information in chapters on “Housing the Horse” (D.S.B. Sainsbury) and “Stable Environment in Relation to the Control of Respiratory Diseases” (A.F. Clarke). *Horse Management*. 1987. John Hickman, editor. Academic Press. London. Approximately \$100.

Visit Penn State’s College of Agricultural Sciences on the Web:  
[www.cas.psu.edu](http://www.cas.psu.edu)

Penn State College of Agricultural Sciences research, extension, and resident education programs are funded in part by Pennsylvania counties, the Commonwealth of Pennsylvania, and the U.S. Department of Agriculture.

This publication is available from the Publications Distribution Center, The Pennsylvania State University, 112 Agricultural Administration Building, University Park, PA 16802. For information telephone 814-865-6713.

Where trade names appear, no discrimination is intended, and no endorsement by Penn State Cooperative Extension is implied.

Issued in furtherance of Cooperative Extension Work, Acts of Congress May 8 and June 30, 1914, in cooperation with the U.S. Department of Agriculture and the Pennsylvania Legislature. T. R. Alter, Director of Cooperative Extension, The Pennsylvania State University.

This publication is available in alternative media on request.

The Pennsylvania State University is committed to the policy that all persons shall have equal access to programs, facilities, admission, and employment without regard to personal characteristics not related to ability, performance, or qualifications as determined by University policy or by state or federal authorities. It is the policy of the University to maintain an academic and work environment free of discrimination, including harassment. The Pennsylvania State University prohibits discrimination and harassment against any person because of age, ancestry, color, disability or handicap, national origin, race, religious creed, sex, sexual orientation, or veteran status. Discrimination or harassment against faculty, staff, or students will not be tolerated at The Pennsylvania State University. Direct all inquiries regarding the nondiscrimination policy to the Affirmative Action Director, The Pennsylvania State University, 328 Boucke Building, University Park, PA 16802-5901, Tel 814-865-4700/V, 814-863-1150/TTY.

© The Pennsylvania State University 2003

Produced by Information and Communication Technologies in the College of Agricultural Sciences

CAT UB039 3M303PS ICT4502