

*Animal Sciences*

# DOG OBEDIENCE: NOVICE AND BEYOND

Leader Guide

Pub. No. 4H439



WISCONSIN 4-H PUBLICATION

HEAD • HEART • HANDS • HEALTH

---

## Contents

<b>Introduction.....</b>	<b>2</b>	<b>The pre-open class.....</b>	<b>6</b>
<b>The novice course.....</b>	<b>2</b>	The heel free, figure 8, and drop on recall.....	6
The heel off leash.....	2	The retrieve on flat.....	6
The training schedule.....	2	Dumbbell size.....	7
<b>The graduate novice course.....</b>	<b>3</b>	The broad jump.....	7
Heel on leash, heel free, and figure 8.....	3	The long sit.....	7
Stand for examination off leash.....	3	The long down.....	7
Drop on recall.....	3	The training schedule.....	7
First week of training.....	3	<b>The open class.....</b>	<b>7</b>
Second week.....	4	The heel free, figure 8, and drop on recall.....	7
Third week.....	4	The retrieve on flat.....	8
Fourth week.....	4	Dumbbell size.....	8
Fifth week.....	4	Retrieve over high jump.....	9
Sixth Week.....	4	The broad jump.....	9
The long sit.....	5	The long sit.....	9
Seventh week.....	5	The long down.....	10
The long down.....	5	The training schedule.....	10
Eighth week.....	5	<b>The pre-utility class.....</b>	<b>10</b>
Training schedule.....	5	The signal exercise.....	10
First week.....	5	Retrieve over high jump.....	10
Second week.....	5	Directed retrieve (seek back).....	10
Third week.....	5	Directed jumping (high jump only).....	11
Fourth week.....	6	The training schedule.....	11
Fifth week.....	6	<b>The utility class.....</b>	<b>11</b>
Sixth Week.....	6	Scent discrimination.....	11
Seventh Week.....	6	Directed retrieve (seek back).....	12
Eighth week.....	6	The signal exercise.....	12
Ninth week.....	6	Directed jumping.....	12
Tenth week.....	6	The trianing schedule.....	12

## Judging Worksheets



---

## Introduction

Boys and girls who have a special talent for training dogs and who have a dog that has trained reasonably well in the Pre-Novice class will enjoy the challenge of more advanced training. Many dogs seem to enjoy the exercises of advanced training more than in the Pre-Novice class. Some dogs especially enjoy the jumping and retrieving exercises. The 4-H leader may also find the challenge of advanced training more interesting.

Many boys and girls who train at this level will enjoy competing in AKC trials and will earn Companion Dog (CD) degrees and others as offered through the American Kennel Club. Through competition of this type you will meet other people who have similar interests in dogs. You will find these people warm and friendly and glad to exchange training ideas.

## The novice course

The Novice class differs from the Pre-Novice by addition of the heel off leash exercise. Dogs should heel well on leash before starting the off leash heeling. Both the instructor and member may find it useful to review the training methods of the Pre-Novice course in the 4-H literature, 4H436, *The Basics of Training Your Dog*.

### The heel off leash

The heel off leash starts from the heel position. Unsnap the leash and have your dog sitting squarely at your heel. Upon the command, "Forward," from your instructor, step off on your left foot while saying the dog's name and "Heel." If he lags or heels wide, give him encouragement to heel by saying his name and repeating the command. If he bolts away, put him back on the leash immediately. Do not let him think you lack control over him because he is off the leash. (See Images 1-3.)

It is important that you show confidence in your dog when training but especially when he is doing exercises off leash. When you step off to heel, give the command in a confident manner and step out briskly. Do not hesitate and look to see if he is keeping up or your dog will almost certainly lag behind and stop. Do the heel off leash for short periods of time; then place him back on leash for more heeling.

Most dogs will become bored at some level of training. Training only once or twice a week or stopping entirely for a week or two may help a dog that is obviously bored with training.

## The training schedule

The class should have nine weekly meetings of one hour duration. The instructor will usually review the exercises at the first meeting and determine the exercises in which each dog needs extra training. At the second meeting, the heel free exercise may be started. The instructor may teach the course so that each dog receives maximum individual attention with problem exercises.

Time should be devoted to teaching the correct manner of conducting each exercise. You should stand and walk arrow straight and look straight ahead while doing the exercises. When doing the recall, do not move your head when calling your dog or give a second command with your shoulders and hips when you finish your dog. Using correct posture will take concentration, especially when in competition. Execute the left and right turns and about turns sharply. Perform all the exercises in a pleasant but businesslike manner.

---

**Image 1: Start training your dog to heel off leash by using a very loose leash. Looping the leash over your shoulder works well.**



---

## The graduate novice course

Graduate Novice training differs from Novice by inclusion of the exercise, “Drop on recall.” The long sit is three minutes and the long down is five minutes in duration, with the handler out of sight. Dogs will be scored using the Graduate Novice scorecard.

### Heel on leash, heel free and figure 8

This exercise should be practiced each week. The heel free and figure 8 are combined into one exercise. Training methods remain the same. Remember to alternate the off leash and on leash training. If your dog lags when doing the figure 8, you may encourage him to go faster by taking short, quick steps especially on the curve where he has the outside path.

### Stand for examination off leash

At this point in training your dog will probably do this exercise well. Repeat it often enough, especially with a stranger, to keep him performing well.

### Drop on recall

#### *First week of training*

Place your dog in the sitting position and step two or three feet away in front of him. (See Image 4.) While saying

“Down,” quickly raise your right hand, palm open, slightly higher than your head; pause for only a moment and bring your hand down sharply. If your dog does not obey, use your left hand to jerk downward on the training collar. After he has been down for a short time, give him the command, “Sit.” You may need to give a jerk upward with the leash. Your dog should go down when your hand goes up. Holding your hand up for a moment the first few days of training may help him learn the signal, but it should soon be a quick up and down motion.

Vary your method of changing your dog from the down to the sitting position. Sometimes command him to sit when you are directly in front of him; other times go back to the heel position, pause a moment and then command him to sit.

After it appears that he understands the hand signal, occasionally leave off the verbal command. Gradually move to the end of the six-foot leash and give the signal and command, “Down.”

Hold your arms at your sides when doing the recall. Your dog may be tempted to nose them if you let them hang.

---

**Image 2: Practice the heel off leash in an area your dog is used to. Also keep safety in mind. Train away from traffic in case your dog decides to run away.**

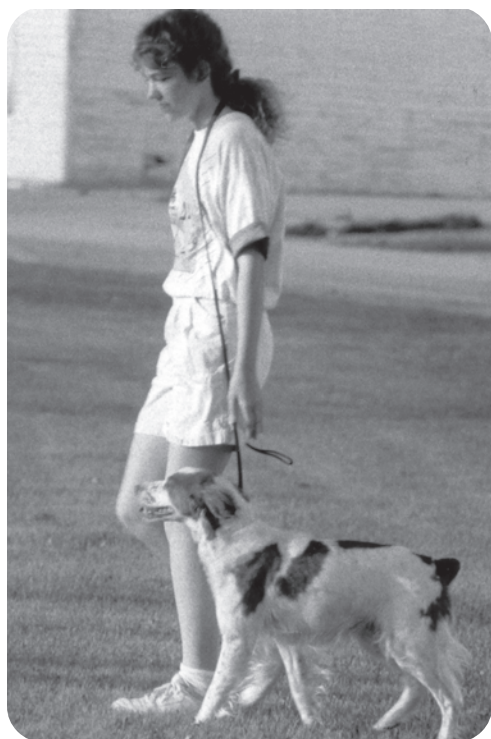

**Image 3: Keep your hand resting comfortably at your side while heeling off leash.**



**Image 4: Begin the recall with your dog at your side in a sitting position. Prepare to leave your dog.**



### *Second week*

When teaching the down, insist on an immediate drop, not a slow sinking to the ground. Do not forget the praise. This is most important.

When your dog seems to understand and obeys your command when you are standing at the end of the leash, you may then remove it and drop him at short distances, gradually moving to 40 feet away. If he does not obey when off leash or at a distance of 40 feet, place him back on leash and repeat the training. For more control at a distance, you may attach a 40-foot lightweight cord. If he does not work well off leash, you will usually make faster progress by placing him back on the six-foot leash.

**Image 5: Move 40 feet away from your dog.**



**Image 6: Call your dog.**



**Image 7: Down your dog. When you finish, remember to praise your dog.**



### *Third week*

The next procedure is teaching your dog to go down from the standing position. Follow the same steps for teaching him the down from the sitting position: Leave him in the standing position, step two or three feet away in front of him, and give the hand signal and command, "Down."

### *Fourth week*

Gradually move back to the end of the 40-foot leash, finally removing the leash and dropping him at this distance. Remember not to say his name before the command, "Down."

### *Fifth week*

Teaching the dog to drop in motion is the next step, but first be sure he understands the other steps. While heeling on leash, suddenly stop and quickly step backward saying your dog's name and "Come." When he starts coming toward you, stop suddenly and give the signal and command, "Down." If your training has been complete up to this point, he should drop on your first attempt. If he does not, give him a sharp correction by putting him down with a jerk on the training collar. After he has been down a few moments, give him the command, "Sit." Then step backward quickly and say his name and "Come." Continue backward until he is in full motion; then stop and have him sit directly to your front just as when doing a recall. Be ready to pull up on the leash to put him in the sit as he may have learned too well on the first try and anticipates a down command. After he has sat in front, send him to heel as the finish of the recall.

Alternate the down and coming to you as the recall. Do not allow him to anticipate commands.

### *Sixth week*

The next step is taught off leash. Place your dog in the sit-stay and take a position 25 feet to his front. Say his name and "Come." When halfway to you, give the command and signal to down. Gradually increase the distance to 40 feet. Drop him at various distances. Alternate with straight recalls so that he will not anticipate commands. (See Images 5-7.)

If he slows down when coming to you in anticipation of a drop, start running backward and say "Come," encouraging him to speed up. Never drop him unless he is coming at full speed as it will only cause him to come in slower and drop without a command or signal.

Do not forget to vary the exercises to prevent boredom. Do not forget the praise.

In an obedience trial, you may use either the command or signal to down your dog. Using both is considered a double



---

command and will be scored against you. Using the signal is preferred as the dog will be more alert and will give you his undivided attention.

### **The long sit**

The handler is out of sight for three minutes.

#### *Seventh week*

By the seventh week your dog well understands when he is being trained and when he is released from training. Take him to a familiar training area where there are buildings, trees or bushes you can easily hide behind. Do not try to hide behind a single tree, a car or other object which might enable him to see a part of you.

Go through several exercises he does best to let him know he is training. Heel him where he can see the corner or edge of your hiding place. Order him to stay and then walk briskly and confidently away without a backward glance. The first several times you should not be out of sight more than a few moments. When you return, pause momentarily before praising and repeating the exercises. It is important that your dog have confidence that you will return to him. This can be accomplished by being out of sight for short periods of time at first and gradually extending the time to three minutes. First, disappear from his sight at short distances and gradually extend to the distance of as much as 100 feet.

---

**Image 8: Practice on a regular basis.**



If your dog breaks from the position to wander off or look for you, you will need a person to signal you so that you can take the dog back to the exact same spot and sternly give him the command to stay again. You may give him a jerk backward with the training collar to further emphasize his staying in that position.

### **The long down**

The handler is out of sight for five minutes.

#### *Eighth week*

This exercise may be taught in the same manner as the long sit. Again, return to the training area that has a building, hallway or dense bushes that will hide you completely from his view. Place him in the down, give a firm command and signal to stay, and walk briskly out of sight. Return after a short time and gradually extend the time to five minutes and the distance to 100 feet. Use the correction methods of the long sit.

### **Training schedule**

The training schedule which follows will not suit the needs of all dogs. Some will learn slower than others. The drop on recall will take considerable time to teach. This exercise has been broken down into weekly portions. Do not advance to the next week's training until he does the preceding part well. Patience is very important in teaching these exercises. (See Image 8.)

#### *First week*

The heel on leash, the heel free and figure 8. These exercises should be practiced at each of the training periods.

Teach the hand signal and command, "Down," when standing directly in front of the dog. During the week of practice, the handler may gradually move to the end of the six-foot leash and alternate leaving off the verbal command.

#### *Second week*

Review the previous lesson. Remove the leash and drop him from distances of not more than 15 feet. During the week of practice, the handler may increase the distance to 40 feet.

#### *Third week*

Review the previous lesson. Teach the dog to "Down" from the standing position. The handler should be standing in front of the dog on leash at a distance of about two or three feet. During the week of practice, the handler may move to the end of the leash. Alternate the use of the command and signal.



#### *Fourth week*

Review the previous lesson. Remove the leash and drop your dog at a distance not greater than 15 feet. During the week of practice the handler may gradually move back to 40 feet.

#### *Fifth week*

Review the previous lesson. Teach the drop in motion on leash. Alternate his dropping in motion and his coming to the sitting position to the handler's front as the recall so that he will not anticipate commands.

#### *Sixth week*

Review the previous lesson. Place your dog in the stand-stay off leash and take a position 25 feet to his front. Say his name and "Come." When halfway in, give him the command and signal to drop. During the week of practice, the handler may extend the distance to 40 feet. Be sure to drop him at various distances and alternate the down command with doing a complete recall.

#### *Seventh week*

Review the previous lesson. The long sit. (Handler out of sight for three minutes.)

The handler should be out of sight of his dog for a short period of time to build the dog's confidence that he will return. During the week of practice the handler may extend the length of time and distance out of sight.

#### *Eighth week*

Review the previous lesson. The long down. (Handler is out of sight for five minutes.) This exercise should be taught in the same manner as the long sit. The other exercises should also be reviewed.

#### *Ninth week*

Review of exercises.

#### *Tenth week*

Graduation.

### The pre-open class

The Pre-Open class escalates from the Graduate Novice by including the retrieve on flat and broad jump. Most dogs will take to the jumping and some will enjoy the retrieving. The retrieving is usually much easier for the sporting and working dogs. The Pre-Open class scorecard will be used for judging.

#### **The heel free, figure 8, and drop on recall**

Practice these exercises every week to keep your dog performing smartly. (See Image 9.)

#### **The retrieve on flat**

For the retrieve on flat, the handler stands with the dog sitting in the heel position. The judge gives the order, "Throw it," whereupon the handler gives the command and signal, "Stay," and throws a dumb-bell about 30 feet directly in front of the dog. He must not give the signal with the hand

**Image 9: Remember to change pace. Try to see how slow you can go.**



**Image 10: The dumbbell should fit comfortably in your dog's mouth.**



in which he holds the dumbbell. The judge will then say "Send your dog," whereupon the handler gives the command, "Take it." The dog should retrieve the dumbbell at a fast trot or gallop. He should sit straight in front within easy reach of the handler and hold the dumbbell in his mouth without chewing or mouthing it. The judge will then order "Take it." and the handler commands his dog "Out" and takes the dumbbell from him. The judge will then order "Finish" and the handler may then give the command or signal to heel as in the recall. The judge may then say, "Exercise finished."

The willingness to learn this exercise will vary a great deal among dogs; however, it is generally not difficult and offers more fun for both the dog and handler than perhaps the other exercises. It can also serve practical uses around the home.



### Dumbbell size

When teaching a dog to retrieve, it is important to use a dumbbell of correct size for the dog. The length of the bar should be about one inch more than the width between the dog's eyes for unobstructed vision. The bells should keep the bar far enough off the ground for the dog to grasp it behind his canine teeth without touching the ground with his nose. The bar should be large enough not to rock in his mouth and pinch his lips but not so large that he drools. (See Image 10.)

Study the size of your dog's mouth carefully before selecting or making a dumbbell. Paint the bells white; your dog may be able to locate the dumbbell more easily and perform better in competition. Do not paint the bar.

### The broad jump

The broad jump is twice as long as the height of the high jump. The greatest length is therefore six feet for large dogs and two feet for small dogs. Build the jump according to Diagram 1. (See Images 11-14.)

### The long sit

Handler out of sight for three minutes.

### The long down

Handler out of sight for five minutes.

### The training schedule

The training schedule for the Pre-Open class will not necessarily meet the needs of each dog. Some will learn faster than others. Each step should be learned reasonably well before starting on the next step lest dog and handler get bogged down in too many problems.

Always begin the week with heeling on leash, some sits, downs and recalls just to remind your dog that it is training time again. Continue with the heel free and figure 8. Then do the retrieve on flat several times.

### The open class

The Open class escalates from the Pre-Open by including the retrieve on flat, retrieve over high jump, and broad jump. Most dogs will take to the jumping and some will enjoy the retrieving. The retrieving is usually much easier for the sporting and working dogs. The 4-H Open class scorecard will be used for judging.

### The heel free, figure 8, and drop on recall

Practice these exercises every week to keep your dog performing smartly.

Diagram 1: The broad jump

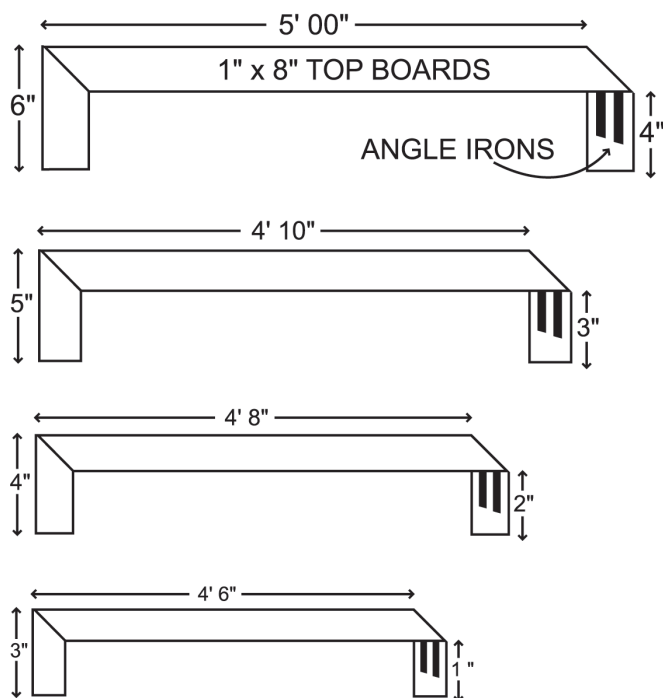

Image 11: Begin teaching the broad jump by running next to the jump while your dog goes over it.



Image 12: Then stand next to the jump, facing it and your dog.



Image 13: Don't forget to encourage your dog.



Image 14: Your dog should finish by turning and sitting square in front of you.





## The retrieve on flat

For the retrieve on flat, the handler stands with the dog sitting in the heel position. The judge gives the order, "Throw it," whereupon the handler gives the command and signal, "Stay," and throws a dumbbell about 30 feet directly in front of the dog. He must not give the signal with the hand in which he holds the dumbbell. The judge will then say, "Send your dog," whereupon the handler gives the command, "Take it." The dog should retrieve the dumbbell at a fast trot or gallop. He should sit straight in front within easy reach of the handler and hold the dumbbell in his mouth without chewing or mouthing it. The judge will then order, "Take it," and the handler commands his dog, "Out," and takes the dumbbell from him. The judge will then order, "Finish," and the handler may then give the command or signal to heel as in the recall. The judge may then say, "Exercise finished."

The willingness to learn this exercise will vary a great deal among dogs; however, it is generally not difficult and offers more fun for both the dog and handler than perhaps the other exercises. It can also serve practical uses around the home.

**Image 15: Your dog should not drop the dumbbell until you command your dog to give it to you.**



## Dumbbell size

When teaching a dog to retrieve, it is important to use a dumbbell of correct size for the dog. The length of the bar should be about one inch more than the width between the dog's eyes for unobstructed vision. The bells should keep the bar far enough off the ground for the dog to grasp it behind his canine teeth without touching the ground with his nose. The bar should be large enough not to rock in his mouth and pinch his lips but not so large that he drools.

Study the size of your dog's mouth carefully before selecting or making a dumbbell. Paint the bells white; your dog may be able to locate the dumbbell more easily and perform better in competition. Do not paint the bar. (See Image 15.)

**Image 16: Keep your dog at your side, in front of the jump while you throw the dumbbell.**



**Image 17: Send your dog.**



**Image 18: Your dog should find the dumbbell on the other side of the jump and pick it up.**



### Retrieve over high jump

Dogs seem to enjoy jumping and will do it readily after they understand the commands. Teach the exercise in parts; do not advance to following parts until your dog performs the first parts well. (See Images 16-20.)

For most dogs, the height of the hurdle is one and one half times higher than their withers (shoulder) or three feet, whichever is less. The Great Dane, Great Pyrenees, Mastiff, Bull Mastiff, Newfoundland, St. Bernard, and Bloodhound

are required to jump only the height of their withers or three feet, whichever is less. Learn to make the hurdle by studying Diagram 2.

### The broad jump

The broad jump is twice as long as the height of the high jump. The greatest length is therefore six feet for large dogs and two feet for small dogs.

### The long sit

Handler out of sight for three minutes.

Diagram 2: The high jump

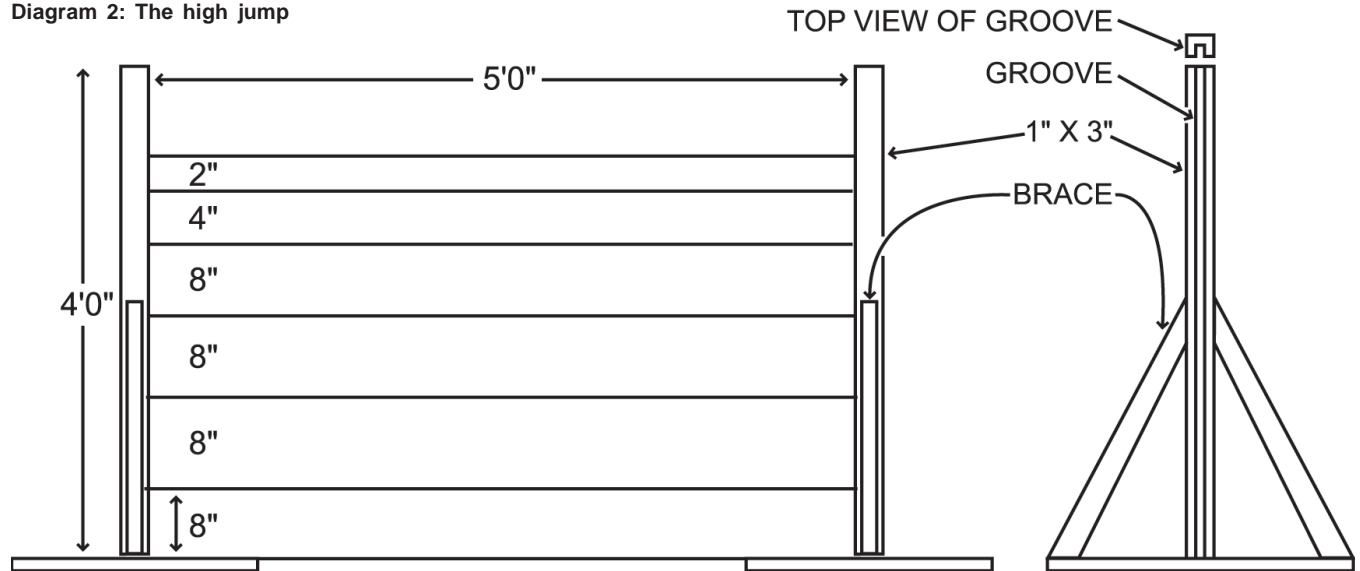

Image 19: Your dog should carry the dumbbell over the jump on the return.



Image 20: Take the dumbbell from your dog when your dog is sitting squarely in front of you.



---

## The long down

Handler out of sight for five minutes.

## The training schedule

The training schedule for the Open class will not necessarily meet the needs of each dog. Some will learn faster than others. Each step should be learned reasonably well before starting on the next step lest dog and handler get bogged down in too many problems.

Always begin the week with heeling on leash, some sits, downs, and recalls just to remind your dog that it is training time again. Continue with the heel free and figure 8. Then do the retrieve on flat several times.

## The pre-utility class

The Pre-Utility class differs markedly from the Open by consisting of signal exercise, retrieve over high jump, directed retrieve, directed jumping (high jump only), and moving stand. The Pre-Utility scorecard will be used for judging.

The jump shall be one and one half times the height of the dog at the withers with a minimum of eight inches and a maximum of 36 inches. This applies to all breeds with the exception of those listed in the AKC rulebook available from the American Kennel Club, 51 Madison Avenue, New York, NY 10010.

All exercises in this class are done off leash. When entering the ring, tell the steward the height your dog should jump and place your directed retrieve articles on the judge's table.

## The signal exercise

The signal exercise is done entirely from hand signals. No verbal commands may be given.

The exercise begins with heeling off leash. The judge will order a "Left turn," "Right turn," "About turn," and "Halt," slow, normal, and fast. Special emphasis will be placed on how you and your dog work as a team. In the process of heeling, the judge will maneuver you to one end of the ring. While heeling, the judge will order, "Stand your dog," and then, "Leave your dog." You should then signal your dog to stand and stay and walk to the far end of the ring (about 50 feet). The judge will then signal you to "Drop your dog," "Sit your dog," "Call your dog," and "Finish," in that order.

Begin teaching these exercises with the signal to heel. Place your dog in the heel position, give him the heel signal (the left hand held open, passed smartly above and forward beside your dog's head). Step off with your left foot and heel

at a brisk pace. If your dog fails to get the idea of the hand signal, place him on leash so you can give a corrective jerk forward with the right hand.

## Retrieve over high jump

Dogs seem to enjoy jumping and will do it readily after they understand the commands. Teach the exercise in parts; do not advance to following parts until your dog performs the first parts well.

For most dogs, the height of the hurdle is one and one half times higher than their withers (shoulder) or three feet, whichever is less. The Great Dane, Great Pyrenees, Mastiff, Bull Mastiff, Newfoundland, St. Bernard, and Bloodhound are required to jump only the height of their withers or three feet, whichever is less.

## Directed retrieve (seek back)

This exercise is conducted as follows: Place your dog in the sitting position facing away from the unobstructed end of the ring. The judge will then drop the three predominately white cotton work gloves across the end of the ring. The gloves shall be designated "One," "Two" or "Three" from left to right when the handler turns and faces the gloves. The judge will order a retrieve of one of the three numbers. The handler will then give the command, "Duke, heel," and will turn in place, either to the right or to the left to face the designated glove. The handler will come to a halt with the dog in the heel position. The handler shall not touch the dog to get it in position. The handler will then give the dog the direction to the designated glove with a single motion of his left hand and arm along the right side of the dog. The handler may give the command to retrieve either simultaneously with or immediately following the giving of the direction. The usual command is, "Duke, get it." The dog shall make the retrieve at a brisk pace, completing the exercise as in the retrieve on the flat. You will be asked to retrieve only one of the three articles.

This exercise will not be difficult for your dog to learn if he is proficient at the retrieve on the flat. When training, select an area that slopes upward from you and your dog. This will enable your dog to see the gloves more easily. In training, give your dog the stay command and signal (dog in sitting position), throw the glove, wait a few seconds, then give the arm signal and command, "Get it." After a few days of training, throw two gloves while he is sitting at heel. Give the signal and command to get the last one thrown, call him in and finish. Then send him to the other glove. Advance to three gloves as soon as he masters retrieving two gloves. After he masters retrieving three gloves, throw only one glove but send him for the other two already in place. He will



---

soon develop a trust of always finding a glove to retrieve when you send him.

### **Directed jumping (high jump only)**

This exercise is conducted as follows: Take a position, with your dog at your heel, and the bar and high jump about 20 feet to your front. The judge will order you to “Send your dog” and you will command your dog, “Go.” The dog should trot out briskly to a point about 20 feet beyond the jump at which time you should command, “Sit.” Your dog should turn and face you in the sitting position. You should then give him the command, “Hup,” and signal him toward the jump. The dog should clear the jump without touching. When the dog is in midair, you may turn to face him as he returns. Then, upon order from the judge, finish your dog by sending him to your heel. You may then praise your dog.

### **The training schedule**

A rigid training schedule is not recommended. Some dogs will advance faster than others. It is important that each new exercise be learned reasonably well before starting on the next step so that both the dog and handler do not get bogged down in too many problems.

Always begin the training period with heeling on leash, some sits, downs and recalls, just to remind your dog that it is training time again. Continue with heel off leash and then go into the most recent exercise taught.

## **The utility class**

The Utility class differs markedly from the Pre-Utility by consisting of scent discrimination of a leather and metal article, directed retrieve, signal exercise, directed jumping, and moving stand. The Utility scorecard will be used for judging.

The jump shall be one and one half times the height of the dog at the withers with a minimum of eight inches and a maximum of 36 inches. This applies to all breeds with the exception of those listed in the AKC rulebook available from the American Kennel Club, 51 Madison Avenue, New York, NY 10010.

All exercises in this class are done off leash. When entering the ring, tell the steward the height your dog should jump, place your box of five leather and five metal scent discrimination articles and your directed retrieve articles on the judge’s table.

### **Scent discrimination**

The following is a description of the scent discrimination exercise. The judge will select one leather and one metal

article from your box and place them on his table. The judge will then tell you where to stand with your dog at the heel position while he places the remaining articles on the ground about 15 feet to your front. The articles will be placed about six inches apart.

At this time the article selected will be passed to you (probably on a clipboard). Show both the judge and steward the number and type of article so they can make a note of it. This eliminates any chance of question of whether the dog retrieves the correct article. You should then turn around so that both you and your dog are facing away from the articles on the ground. Rub the article with your hands to place your scent on it. After several seconds the judge will take it from you by asking you to place it on a clipboard. He will then, without touching it with his hands, place it among the articles on the ground. He will then order you to “Send your dog.” You should then say, “Duke, heel,” and do an about turn in place to your right. As you turn around and face the articles command, “Duke, get it.” Your dog should go briskly to the articles and search out the scented article. He should return quickly without mouthing, and sit straight in front of you, holding it patiently. The judge will then order, “Take it.” After you have removed the article from his mouth, the judge will order, “Finish,” and you will command, “Duke, heel.” You will then follow the same procedure with the remaining article.

Your dog must be proficient at retrieving before learning the scent discrimination exercise. First carry one of the leather articles in your pocket for a week to allow it to become thoroughly impregnated with your scent. Then take the dog to a quiet place and throw the article 10 or 15 feet and command, “Get it.” Don’t forget to praise. Always rub the article with your hands just before throwing to add fresh scent to the article. Next place a clean unscented article and throw the scented article nearby. Send your dog. If he starts to pick up the unscented article, say, “No.” If he does pick up the article, rush to him and flick it from his mouth. Guide him to pick up the scented article. Lavish praise is important.

Some trainers fasten the unscented article with wire or nails to a sheet of plywood. The dog then learns that the unscented article cannot be picked up. This method has worked well and is suggested. After the dog has learned to distinguish the scented from the unscented, fasten more articles down. He will then learn to smell each article until finding the one with the scent. Follow this procedure with the metal articles. Then use some of each, finally using all of the articles.



---

When training, it is important to handle the unscented articles in a manner to not confuse the dog. Prepare unscented articles by washing them with hot water and soap. Let them dry in the air. Use a pair of tongs to pick them up.

Use the same methods for teaching the exercises in the Utility class as you used in the Pre-Novice class. They are praise, correction and persistence. Be definite with each. Your timing at using each is most important.

### **Directed retrieve (seek back)**

This exercise is conducted as follows: Place your dog in the sitting position facing away from the unobstructed end of the ring. The judge will then drop the three predominately white cotton work gloves across the end of the ring. The gloves shall be designated "One," "Two" or "Three" from left to right when the handler turns and faces the gloves. The judge will order a retrieve of one of the three numbers. The handler will then give the command, "Duke, heel," and will turn in place, either to the right or to the left, to face the designated glove. The handler will come to a halt with the dog in the heel position. The handler shall not touch the dog to get it in position. The handler will then give the dog the direction to the designated glove with a single motion of his left hand and arm along the right side of the dog. The handler may give the command to retrieve either simultaneously with or immediately following the giving of the direction. The usual command is, "Duke, get it." The dog shall make the retrieve at a brisk pace, completing the exercise as in the retrieve on the flat. You will be asked to retrieve only one of the three articles.

This exercise will not be difficult for your dog to learn if he is proficient at the retrieve on the flat. When training, select an area that slopes upward from you and your dog. This will enable your dog to see the gloves more easily. In training, give your dog the stay command and signal (dog in sitting position), throw the glove, wait a few seconds, then give the arm signal and command, "Get it." After a few days of training, throw two gloves while he is sitting at heel. Give the signal and command to get the last one thrown, call him in and finish. Then send him to the other glove. Advance to three gloves as soon as he masters retrieving two gloves. After he masters retrieving three gloves, throw only one glove but send him for the other two already in place. He will soon develop a trust of always finding a glove to retrieve when you send him.

### **The signal exercise**

The signal exercise is done entirely from hand signals. No verbal commands may be given.

The exercise begins with heeling off leash. The judge will order a "Left turn," "Right turn," "About turn," and "Halt," slow, normal, and fast. Special emphasis will be placed on how you and your dog work as a team. In the process of heeling, the judge will maneuver you to one end of the ring. While heeling, the judge will order, "Stand your dog," and then, "Leave your dog." You should then signal your dog to stand and stay and walk to the far end of the ring (about 50 feet). The judge will then signal you to "Drop your dog," "Sit your dog," "Call your dog," and "Finish," in that order.

Begin teaching these exercises with the signal to heel. Place your dog in the heel position, give him the heel signal (the left hand held open, passed smartly above and forward beside your dog's head). Step off with your left foot and heel at a brisk pace. If your dog fails to get the idea of the hand signal, place him on leash so you can give a corrective jerk forward with the right hand.

### **Directed jumping**

This exercise is conducted as follows: Take a position, with your dog at your heel, and the bar and high jump about 20 feet to your front. The judge will order you to "Send your dog" and you will command your dog, "Go." The dog should trot out briskly to a point about 20 feet beyond the jump at which time you should command, "Sit." Your dog should turn and face you in the sitting position. At this time the judge will tell you which jump you should send your dog over. You should then give him the command, "Hup," and signal him toward the jump. The dog should clear the jump without touching. When the dog is in midair you may turn to face him as he returns. Then, upon order from the judge, finish your dog by sending him to your heel. You may then praise your dog. Repeat this exercise by sending him over the other jump.

### **The training schedule**

A rigid training schedule is not recommended. Some dogs will advance faster than others. It is important that each new exercise be learned reasonably well before starting on the next step so that both the dog and handler do not get bogged down in too many problems.

Always begin the training period with heeling on leash, some sits, downs and recalls, just to remind your dog that it is training time again. Continue with heel off leash and then go into the most recent exercise taught.





Novice Class

# OBEDIENCE JUDGE'S WORKSHEET

Wisconsin For Judge's Use ONLY - Not to be distributed

Pub. No. 4H439

Date: \_\_\_\_\_ Dog No.: \_\_\_\_\_

Show: \_\_\_\_\_ Breed: \_\_\_\_\_ Judge: \_\_\_\_\_

Exercise	Non Qualifying		Qualifying		Max points	Points off	Net score
	Zero	Less than 50%	Substantial	Minor			
<b>Heel on leash and figure 8</b>	Unmanageable..... <input type="checkbox"/>	Handler continually adapts pace to dog..... <input type="checkbox"/>	<input type="checkbox"/> Forges..... <input type="checkbox"/> <input type="checkbox"/> Lags..... <input type="checkbox"/> <input type="checkbox"/> Crowds handler..... <input type="checkbox"/> <input type="checkbox"/> No change of pace <input type="checkbox"/> fast <input type="checkbox"/> slow..... <input type="checkbox"/> <input type="checkbox"/> Sniffs..... <input type="checkbox"/> <input type="checkbox"/> Needs extra command/signal..... <input type="checkbox"/> <input type="checkbox"/> Heels wide <input type="checkbox"/> turning <input type="checkbox"/> reversing <input type="checkbox"/> <input type="checkbox"/> No sits Poor sits..... <input type="checkbox"/> <input type="checkbox"/> Improper heel position..... <input type="checkbox"/> <input type="checkbox"/> Occasional tight leash..... <input type="checkbox"/> <input type="checkbox"/> Lacks naturalness/smoothness..... <input type="checkbox"/> <input type="checkbox"/> Handler error..... <input type="checkbox"/>	Heeling Fig. 8 <input type="checkbox"/> <input type="checkbox"/> <input type="checkbox"/> <input type="checkbox"/> <input type="checkbox"/> <input type="checkbox"/> <input type="checkbox"/> <input type="checkbox"/> <input type="checkbox"/> <input type="checkbox"/> <input type="checkbox"/>	<b>40</b>		
	Unqualified heeling..... <input type="checkbox"/>	Constantly tugs on leash or guiding... <input type="checkbox"/>					
<b>Stand for exam (off leash)</b>	Sits before/during examination..... <input type="checkbox"/>	Moves away before/during examination..... <input type="checkbox"/>	<input type="checkbox"/> Resists handler posing..... <input type="checkbox"/> <input type="checkbox"/> Needs extra command to stay..... <input type="checkbox"/> <input type="checkbox"/> Moves slightly during exam..... <input type="checkbox"/> <input type="checkbox"/> Moves after examination..... <input type="checkbox"/> <input type="checkbox"/> Sits as handler returns..... <input type="checkbox"/> <input type="checkbox"/> Lacks naturalness/smoothness..... <input type="checkbox"/> <input type="checkbox"/> Handler error..... <input type="checkbox"/>		<b>30</b>		
	Growls or snaps... <input type="checkbox"/>	Shows shyness/resentment..... <input type="checkbox"/>					
<b>Heel off leash</b>	Unmanageable..... <input type="checkbox"/>	Handler continually adapts pace to dog..... <input type="checkbox"/>	<input type="checkbox"/> Forges..... <input type="checkbox"/> <input type="checkbox"/> Lags..... <input type="checkbox"/> <input type="checkbox"/> Crowds handler..... <input type="checkbox"/> <input type="checkbox"/> Sniffs..... <input type="checkbox"/> <input type="checkbox"/> Improper heel position..... <input type="checkbox"/> <input type="checkbox"/> No change of pace <input type="checkbox"/> fast <input type="checkbox"/> slow..... <input type="checkbox"/> <input type="checkbox"/> Lacks naturalness/smoothness..... <input type="checkbox"/> <input type="checkbox"/> Needs extra command to heel..... <input type="checkbox"/> <input type="checkbox"/> Heels wide <input type="checkbox"/> turning <input type="checkbox"/> reversing..... <input type="checkbox"/> <input type="checkbox"/> No sits Poor sits..... <input type="checkbox"/> <input type="checkbox"/> Handler error..... <input type="checkbox"/>		<b>40</b>		
	Unqualified heeling..... <input type="checkbox"/>	Leaves handler.... <input type="checkbox"/>					
<b>Recall</b>	Does not come on first command or signal..... <input type="checkbox"/>	Extra command or signal to stay..... <input type="checkbox"/>  Moves from position..... <input type="checkbox"/>  Anticipates recall..... <input type="checkbox"/> Sits out of reach.. <input type="checkbox"/> Leaves handler.... <input type="checkbox"/>	<input type="checkbox"/> Stands or lays down Touches handler... <input type="checkbox"/> <input type="checkbox"/> Needs extra command/signal to finish Sits between feet... <input type="checkbox"/> <input type="checkbox"/> Returns slowly Poor finish..... <input type="checkbox"/> <input type="checkbox"/> Responds slowly Poor sit..... <input type="checkbox"/> <input type="checkbox"/> No sit in front Lacks smoothness.. <input type="checkbox"/> <input type="checkbox"/> No finish Lacks naturalness.. <input type="checkbox"/> <input type="checkbox"/> Handler's arms not at side <input type="checkbox"/> Didn't know how to execute recall properly <input type="checkbox"/> Handler error		<b>30</b>		
<b>Maximum Sub-Total</b>					<b>140</b>		
<b>Long sit (1 minute) off leash</b>	Stands/lays within 15 sec. .... <input type="checkbox"/>	Stands/lays within 15 - 30 sec. .... <input type="checkbox"/>	<input type="checkbox"/> Forced into position <input type="checkbox"/> Lays/stands in 30-60 seconds <input type="checkbox"/> Minor move <i>before</i> handler returns	Minor move <i>after</i> handler returns..... <input type="checkbox"/>	<b>30</b>		
	Disturbs another dog..... <input type="checkbox"/>	Repeatedly whines or barks..... <input type="checkbox"/>	<input type="checkbox"/> Handler error	Minor whine/bark.. <input type="checkbox"/>			
<b>Long down (3 minutes) off leash</b>	Does not remain in place up to 1 min. .... <input type="checkbox"/>	Stands/sits within 1-2 min..... <input type="checkbox"/>	<input type="checkbox"/> Forced into position <input type="checkbox"/> Sits/stands in 2-3 minutes <input type="checkbox"/> Minor move <i>before</i> handler returns	Minor move <i>after</i> handler returns..... <input type="checkbox"/>	<b>30</b>		
	Disturbs another dog..... <input type="checkbox"/>	Repeatedly whines or barks..... <input type="checkbox"/>	<input type="checkbox"/> Handler error	Minor whine/bark.. <input type="checkbox"/>			
<b>Maximum Points</b>					<b>200</b>		
<input type="checkbox"/> Disciplining	<input type="checkbox"/> Shows fear	<input type="checkbox"/> Fouls ring	<input type="checkbox"/> Leaves ring	<b>Less penalty for unusual behavior</b>			
<input type="checkbox"/> Disqualified	<input type="checkbox"/> Expelled	<input type="checkbox"/> Excused	<input type="checkbox"/> Other				
Explanation of penalty					<b>TOTALNETSCORE</b>		



Graduate Novice

# OBEDIENCE JUDGE'S WORKSHEET

Wisconsin For Judge's Use ONLY - Not to be distributed

Pub. No. 4H439

Date: \_\_\_\_\_ Dog No.: \_\_\_\_\_

Show: \_\_\_\_\_ Breed: \_\_\_\_\_ Judge: \_\_\_\_\_

Exercise	Non Qualifying		Qualifying		Max points	Points off	Net score
	Zero	Less than 50%	Substantial	Minor			
<b>Heel on leash</b>	Unmanageable... <input type="checkbox"/>  Unqualified heeling... <input type="checkbox"/>	Handler continually adapts pace to dog... <input type="checkbox"/>  Constant tight leash or guiding... <input type="checkbox"/>  Leaves handler... <input type="checkbox"/>	<input type="checkbox"/> Forges... <input type="checkbox"/> <input type="checkbox"/> Lags... <input type="checkbox"/> <input type="checkbox"/> Dog interferes with handler... <input type="checkbox"/> <input type="checkbox"/> No change of pace... <input type="checkbox"/> <input type="checkbox"/> Sniffs... <input type="checkbox"/> <input type="checkbox"/> Needs extra command/signal... <input type="checkbox"/> <input type="checkbox"/> Heels wide <input type="checkbox"/> turning <input type="checkbox"/> reversing... <input type="checkbox"/> <input type="checkbox"/> Handler error <input type="checkbox"/> Poor sits... <input type="checkbox"/>		<b>30</b>		
<b>Stand for exam (off leash)</b>	Sits before/during examination... <input type="checkbox"/>  Growls or snaps... <input type="checkbox"/>	Moves away before/during examination... <input type="checkbox"/>  Shows shyness/resentment... <input type="checkbox"/>	<input type="checkbox"/> Needs extra command/signal... <input type="checkbox"/> <input type="checkbox"/> Moves feet... <input type="checkbox"/> <input type="checkbox"/> Moves after exam completed... <input type="checkbox"/> <input type="checkbox"/> Sits as handler returns... <input type="checkbox"/> <input type="checkbox"/> Handler error... <input type="checkbox"/>		<b>30</b>		
<b>Heel free and figure 8 (off leash)</b>	Unmanageable... <input type="checkbox"/>  Unqualified heeling... <input type="checkbox"/>	Handler continually adapts pace to dog... <input type="checkbox"/>  Leaves handler... <input type="checkbox"/>	<input type="checkbox"/> Forges... <input type="checkbox"/> <input type="checkbox"/> Lags... <input type="checkbox"/> <input type="checkbox"/> Crowds handler... <input type="checkbox"/> <input type="checkbox"/> Sniffs... <input type="checkbox"/> <input type="checkbox"/> Needs extra command/signal... <input type="checkbox"/> <input type="checkbox"/> Heels wide <input type="checkbox"/> turning <input type="checkbox"/> reversing... <input type="checkbox"/> <input type="checkbox"/> Handler error <input type="checkbox"/> Poor sits... <input type="checkbox"/>	Heeling Fig. 8 <input type="checkbox"/>	<b>40</b>		
<b>Drop on recall</b>	Does not come on first command or signal... <input type="checkbox"/>  Does not drop on first command or signal... <input type="checkbox"/>  Sits out of reach... <input type="checkbox"/>	Extra command or signal to stay after handler leaves... <input type="checkbox"/>  Moves from place left... <input type="checkbox"/>  Anticipates: Recall... <input type="checkbox"/> Drop... <input type="checkbox"/> Come in... <input type="checkbox"/>	<input type="checkbox"/> Stands or lays down <input type="checkbox"/> <input type="checkbox"/> Extra command/signal before handler leaves <input type="checkbox"/> <input type="checkbox"/> Returns slowly <input type="checkbox"/> <input type="checkbox"/> Drops slowly <input type="checkbox"/> <input type="checkbox"/> Responds slowly <input type="checkbox"/> <input type="checkbox"/> No sit in front <input type="checkbox"/> <input type="checkbox"/> No finish <input type="checkbox"/> <input type="checkbox"/> Handler error <input type="checkbox"/>	Touches handler... <input type="checkbox"/> Sits between feet... <input type="checkbox"/> Poor finish... <input type="checkbox"/> Poor sit... <input type="checkbox"/> Lacks smoothness... <input type="checkbox"/> Lacks naturalness... <input type="checkbox"/>	<b>40</b>		
<b>Maximum Sub-Total</b>					<b>140</b>		
<b>Long sit (3 minutes) Handler out of sight</b>	Does not remain in place up to 1 min. .... <input type="checkbox"/>  Disturbs another dog... <input type="checkbox"/>	Stands/lays within 1-2 min. .... <input type="checkbox"/>  Repeatedly whines or barks... <input type="checkbox"/>	<input type="checkbox"/> Forced into position <input type="checkbox"/> <input type="checkbox"/> Stands/lays in 2-3 min. <input type="checkbox"/> <input type="checkbox"/> Minor move <i>before</i> handler returns <input type="checkbox"/> <input type="checkbox"/> Handler error <input type="checkbox"/>	Minor move <i>after</i> handler returns to heel position... <input type="checkbox"/> Rough treatment... <input type="checkbox"/>  Minor whine/bark... <input type="checkbox"/>	<b>30</b>		
<b>Long down (5 minutes) Handler out of sight</b>	Does not remain in place up to 2 min. .... <input type="checkbox"/>  Disturbs another dog... <input type="checkbox"/>	Stands/lays within 2-4 min... <input type="checkbox"/>  Repeatedly whines or barks... <input type="checkbox"/>	<input type="checkbox"/> Forced into position <input type="checkbox"/> <input type="checkbox"/> Stands/lays in 4-5 min. <input type="checkbox"/> <input type="checkbox"/> Minor move <i>before</i> handler returns <input type="checkbox"/> <input type="checkbox"/> Handler error <input type="checkbox"/>	Minor move <i>after</i> handler returns to heel position... <input type="checkbox"/>  Minor whine/bark... <input type="checkbox"/>	<b>30</b>		
<b>Maximum Points</b>					<b>200</b>		
<input type="checkbox"/> Disciplining	<input type="checkbox"/> Shows fear	<input type="checkbox"/> Fouls ring	<input type="checkbox"/> Leaves ring	<input type="checkbox"/> Less penalty for unusual behavior			
<input type="checkbox"/> Disqualified	<input type="checkbox"/> Expelled	<input type="checkbox"/> Excused	<input type="checkbox"/> Other				
Explanation of penalty					<b>TOTALNETSCORE</b>		



Pre-Open Class

# OBEDIENCE JUDGE'S WORKSHEET

Wisconsin For Judge's Use ONLY - Not to be distributed

Pub. No. 4H439

Date: \_\_\_\_\_ Dog No.: \_\_\_\_\_

Show: \_\_\_\_\_ Breed: \_\_\_\_\_ Height (at withers): \_\_\_\_\_

Jumps: \_\_\_\_\_ Judge: \_\_\_\_\_

**All exercises will be off lead.**

Exercise	Non Qualifying		Qualifying		Max points	Points off	Net score
	Zero	Less than 50%	Substantial	Minor			
<b>Heel free and figure 8</b>	Unmanageable... <input type="checkbox"/>	Handler continually adapts pace to dog... <input type="checkbox"/>	<input type="checkbox"/> Improper heel position... <input type="checkbox"/> <input type="checkbox"/> Forges... <input type="checkbox"/> <input type="checkbox"/> Lags... <input type="checkbox"/> <input type="checkbox"/> Crowds handler... <input type="checkbox"/> <input type="checkbox"/> Sniffs... <input type="checkbox"/> <input type="checkbox"/> Needs extra command to heel... <input type="checkbox"/> <input type="checkbox"/> Heels wide <input type="checkbox"/> turning <input type="checkbox"/> reversing <input type="checkbox"/> <input type="checkbox"/> No change of pace <input type="checkbox"/> fast <input type="checkbox"/> slow... <input type="checkbox"/> <input type="checkbox"/> No sits <input type="checkbox"/> Poor sits... <input type="checkbox"/> <input type="checkbox"/> Lacks naturalness/smoothness... <input type="checkbox"/> <input type="checkbox"/> Handler error	Heeling Fig. 8 <input type="checkbox"/>	<b>40</b>		
	Unqualified heeling... <input type="checkbox"/>	Leaves handler... <input type="checkbox"/>					
<b>Drop on recall</b>	Does not come on first command or signal... <input type="checkbox"/>	Extra command or signal to stay after handler leaves... <input type="checkbox"/> Moves from place left... <input type="checkbox"/> Anticipates: Recall... <input type="checkbox"/> Drop... <input type="checkbox"/> Come in... <input type="checkbox"/> Sits out of reach... <input type="checkbox"/>	<input type="checkbox"/> Stands or lays down <input type="checkbox"/> Extra command/signal before handler leaves <input type="checkbox"/> Returns slowly <input type="checkbox"/> Drops slowly <input type="checkbox"/> Responds slowly <input type="checkbox"/> No sit in front <input type="checkbox"/> No finish <input type="checkbox"/> Handler error	<input type="checkbox"/> Touches handler... <input type="checkbox"/> <input type="checkbox"/> Sits between feet... <input type="checkbox"/> <input type="checkbox"/> Poor finish... <input type="checkbox"/> <input type="checkbox"/> Poor sit... <input type="checkbox"/> <input type="checkbox"/> Lacks smoothness... <input type="checkbox"/> <input type="checkbox"/> Lacks naturalness... <input type="checkbox"/>	<b>40</b>		
	Does not drop on first command or signal... <input type="checkbox"/>						
<b>Retrieve on flat</b>	Fails to go out on first command or signal... <input type="checkbox"/>	Goes before command or signal... <input type="checkbox"/> Needs extra command/signal... <input type="checkbox"/>	<input type="checkbox"/> Slow <input type="checkbox"/> Going <input type="checkbox"/> Returning... <input type="checkbox"/> <input type="checkbox"/> Mouthing or playing... <input type="checkbox"/> <input type="checkbox"/> Drops dumbbell <input type="checkbox"/> Poor delivery <input type="checkbox"/> No sit in front <input type="checkbox"/> No finish <input type="checkbox"/> Handler error	<input type="checkbox"/> Touches handler... <input type="checkbox"/> <input type="checkbox"/> Sits between feet... <input type="checkbox"/> <input type="checkbox"/> Poor sit... <input type="checkbox"/> <input type="checkbox"/> Poor finish... <input type="checkbox"/>	<b>30</b>		
	Fails to retrieve... <input type="checkbox"/>	Sits out of reach... <input type="checkbox"/>					
<b>Broad jump</b>	Refuses to jump on first command or signal... <input type="checkbox"/>	Goes before command or signal... <input type="checkbox"/> Does not clear jump... <input type="checkbox"/> Sits out of reach... <input type="checkbox"/>	<input type="checkbox"/> Minor jump touch <input type="checkbox"/> Poor return <input type="checkbox"/> No sit in front <input type="checkbox"/> No finish <input type="checkbox"/> Handler error	<input type="checkbox"/> Touches handler... <input type="checkbox"/> <input type="checkbox"/> Sits between feet <input type="checkbox"/> <input type="checkbox"/> Poor sit... <input type="checkbox"/> <input type="checkbox"/> Poor finish... <input type="checkbox"/>	<b>30</b>		
	Walks on jump... <input type="checkbox"/>						
<b>Maximum Sub-Total</b>					<b>140</b>		
<b>Long sit (3 minutes)</b>	Does not remain in place... <input type="checkbox"/>	Stands/lays before handler returns... <input type="checkbox"/>	<input type="checkbox"/> Forced into position <input type="checkbox"/> Handler error	<input type="checkbox"/> Minor move before/after handler returns to heel position... <input type="checkbox"/> <input type="checkbox"/> Minor whine/bark... <input type="checkbox"/>	<b>30</b>		
	Goes to another dog... <input type="checkbox"/>	Repeatedly whines or barks... <input type="checkbox"/>					
<b>Long down (5 minutes)</b>	Does not remain in place... <input type="checkbox"/>	Stands/lays before handler returns... <input type="checkbox"/>	<input type="checkbox"/> Forced into position <input type="checkbox"/> Handler error	<input type="checkbox"/> Minor move before/after handler returns to heel position... <input type="checkbox"/> <input type="checkbox"/> Minor whine/bark... <input type="checkbox"/>	<b>30</b>		
	Goes to another dog... <input type="checkbox"/>	Repeatedly whines or barks... <input type="checkbox"/>					
<b>Maximum Points</b>					<b>200</b>		
<input type="checkbox"/> Disciplining <input type="checkbox"/> Shows fear <input type="checkbox"/> Fouls ring <input type="checkbox"/> Disqualified <input type="checkbox"/> Expelled <input type="checkbox"/> Excused					<b>Less penalty for unusual behavior</b>		
Explanation of penalty					<b>TOTALNET SCORE</b>		





Open Class

# OBEDIENCE JUDGE'S WORKSHEET

Wisconsin For Judge's Use ONLY - Not to be distributed

Pub. No. 4H439

Date: \_\_\_\_\_ Dog No.: \_\_\_\_\_

Show: \_\_\_\_\_ Breed: \_\_\_\_\_ Height (at withers): \_\_\_\_\_

Jumps: \_\_\_\_\_ Judge: \_\_\_\_\_

Exercise	Non Qualifying		Qualifying		Max points	Points off	Net score
	Zero	Less than 50%	Substantial	Minor			
<b>Heel free and figure 8</b>	Unmanageable... <input type="checkbox"/>  Unqualified heeling... <input type="checkbox"/>	Handler continually adapts pace to dog... <input type="checkbox"/>  Leaves handler... <input type="checkbox"/>	<input type="checkbox"/> Improper heel position..... <input type="checkbox"/> <input type="checkbox"/> Forges <input type="checkbox"/> Crowds handler..... <input type="checkbox"/> <input type="checkbox"/> Lags <input type="checkbox"/> Sniffs..... <input type="checkbox"/> <input type="checkbox"/> Needs extra command to heel..... <input type="checkbox"/> <input type="checkbox"/> Heels wide <input type="checkbox"/> turning <input type="checkbox"/> reversing <input type="checkbox"/> <input type="checkbox"/> No change of pace <input type="checkbox"/> fast <input type="checkbox"/> slow..... <input type="checkbox"/> <input type="checkbox"/> No sit <input type="checkbox"/> Poor sits..... <input type="checkbox"/> <input type="checkbox"/> Handler error	Heeling Fig. 8 <input type="checkbox"/> <input type="checkbox"/> <input type="checkbox"/> <input type="checkbox"/> <input type="checkbox"/> <input type="checkbox"/> <input type="checkbox"/>	<b>40</b>		
<b>Drop on recall</b>	Does not come on first command or signal... <input type="checkbox"/>  Does not drop on first command or signal... <input type="checkbox"/>	Extra command or signal to stay after handler leaves... <input type="checkbox"/> Moves from place left... <input type="checkbox"/> Anticipates: Recall... <input type="checkbox"/> Drop... <input type="checkbox"/> Come in... <input type="checkbox"/> Sits out of reach... <input type="checkbox"/>	<input type="checkbox"/> Stands or lays down <input type="checkbox"/> Extra command/signal before handler leaves <input type="checkbox"/> Returns slowly <input type="checkbox"/> Drops slowly <input type="checkbox"/> Responds slowly <input type="checkbox"/> No sit in front <input type="checkbox"/> No finish <input type="checkbox"/> Handler error	Touches handler... <input type="checkbox"/> Sits between feet... <input type="checkbox"/> Poor finish... <input type="checkbox"/> Poor sit... <input type="checkbox"/> Lacks smoothness... <input type="checkbox"/> Lacks naturalness... <input type="checkbox"/>	<b>30</b>		
<b>Retrieve on flat</b>	Fails to go out on first command or signal... <input type="checkbox"/>  Fails to retrieve... <input type="checkbox"/>	Goes before command or signal... <input type="checkbox"/> Needs extra command/signal... <input type="checkbox"/> Sits out of reach... <input type="checkbox"/>	<input type="checkbox"/> Slow <input type="checkbox"/> Going <input type="checkbox"/> Returning..... <input type="checkbox"/> <input type="checkbox"/> Mouthing or playing..... <input type="checkbox"/> <input type="checkbox"/> Drops dumbbell <input type="checkbox"/> Poor delivery <input type="checkbox"/> No sit in front <input type="checkbox"/> No finish <input type="checkbox"/> Handler error	Touches handler... <input type="checkbox"/> Sits between feet... <input type="checkbox"/> Poor sit... <input type="checkbox"/> Poor finish... <input type="checkbox"/>	<b>25</b>		
<b>Retrieve over high jump</b>	Fails to go out on first command or signal... <input type="checkbox"/>  Fails to jump either direction... <input type="checkbox"/> Fails to retrieve... <input type="checkbox"/>	Goes before command or signal... <input type="checkbox"/> Jumps only one direction... <input type="checkbox"/> Sits out of reach... <input type="checkbox"/> Extra command or signal... <input type="checkbox"/>	<input type="checkbox"/> Slow <input type="checkbox"/> Going <input type="checkbox"/> Returning..... <input type="checkbox"/> <input type="checkbox"/> Mouthing or playing..... <input type="checkbox"/> <input type="checkbox"/> Drops dumbbell <input type="checkbox"/> Poor delivery <input type="checkbox"/> Climbs jump <input type="checkbox"/> No sit in front <input type="checkbox"/> No finish <input type="checkbox"/> Handler error	Touches handler... <input type="checkbox"/> Sits between feet... <input type="checkbox"/> Poor sit... <input type="checkbox"/> Poor finish... <input type="checkbox"/>	<b>35</b>		
<b>Broad jump</b>	Refuses to jump on first command or signal... <input type="checkbox"/>  Walks on jump... <input type="checkbox"/>	Goes before command or signal... <input type="checkbox"/> Does not clear jump... <input type="checkbox"/> Sits out of reach... <input type="checkbox"/>	<input type="checkbox"/> Minor jump touch <input type="checkbox"/> Poor return <input type="checkbox"/> No sit in front <input type="checkbox"/> No finish <input type="checkbox"/> Handler error	Touches handler... <input type="checkbox"/> Sits between feet <input type="checkbox"/> Poor sit... <input type="checkbox"/> Poor finish... <input type="checkbox"/>	<b>20</b>		
<b>Maximum Sub-Total</b>					<b>150</b>		
<b>Long sit (3 minutes)</b>	Does not remain in place... <input type="checkbox"/>  Goes to another dog... <input type="checkbox"/>	Stands/lays before handler returns... <input type="checkbox"/>  Repeatedly whines or barks... <input type="checkbox"/>	<input type="checkbox"/> Forced into position  <input type="checkbox"/> Handler error	Minor move before/after handler returns to heel position... <input type="checkbox"/> Minor whine/bark... <input type="checkbox"/>	<b>25</b>		
<b>Long down (5 minutes)</b>	Does not remain in place... <input type="checkbox"/>  Goes to another dog... <input type="checkbox"/>	Stands/lays before handler returns... <input type="checkbox"/>  Repeatedly whines or barks... <input type="checkbox"/>	<input type="checkbox"/> Forced into position  <input type="checkbox"/> Handler error	Minor move before/after handler returns to heel position... <input type="checkbox"/> Minor whine/bark... <input type="checkbox"/>	<b>25</b>		
<b>Maximum Points</b>					<b>200</b>		
<input type="checkbox"/> Disciplining	<input type="checkbox"/> Shows fear	<input type="checkbox"/> Fouls ring	<b>Less penalty for unusual behavior</b>				
<input type="checkbox"/> Disqualified	<input type="checkbox"/> Expelled	<input type="checkbox"/> Excused					
Explanation of penalty					<b>TOTAL NET SCORE</b>		



Pre-Utility

# OBEDIENCE JUDGE'S WORKSHEET

Wisconsin For Judge's Use ONLY - Not to be distributed

Pub. No. 4H439

Date: \_\_\_\_\_ Article No.: \_\_\_\_\_ Dog No.: \_\_\_\_\_

Show: \_\_\_\_\_ Breed: \_\_\_\_\_ Height (at withers): \_\_\_\_\_

Jumps: \_\_\_\_\_ Judge: \_\_\_\_\_

Exercise	Non Qualifying		Qualifying		Max points	Points off	Net score
	Zero	Less than 50%	Substantial	Minor			
<b>Signal exercise</b>	Handler adapts to dog's pace..... <input type="checkbox"/>  Unmanageable..... <input type="checkbox"/>  Unqualified heeling..... <input type="checkbox"/>  Any audible commands..... <input type="checkbox"/>	Failure on first signal to: Stand..... <input type="checkbox"/> Stay..... <input type="checkbox"/> Drop..... <input type="checkbox"/> Sit..... <input type="checkbox"/> Come..... <input type="checkbox"/>  Anticipates..... <input type="checkbox"/> Sits out of reach.. <input type="checkbox"/>	<input type="checkbox"/> Forges <input type="checkbox"/> Lags <input type="checkbox"/> No change of pace <input type="checkbox"/> Heels wide <input type="checkbox"/> Needs extra signal <input type="checkbox"/> Holding signals..... <input type="checkbox"/> <input type="checkbox"/> Responds slowly to: <input type="checkbox"/> Stand..... <input type="checkbox"/> Down..... <input type="checkbox"/> Sit..... <input type="checkbox"/> Come..... <input type="checkbox"/> <input type="checkbox"/> No sit front/finish <input type="checkbox"/> Lacks naturalness/smoothness <input type="checkbox"/> Handler error	<input type="checkbox"/> Crowds handler..... <input type="checkbox"/> <input type="checkbox"/> Sniffs..... <input type="checkbox"/> <input type="checkbox"/> fast <input type="checkbox"/> slow..... <input type="checkbox"/> <input type="checkbox"/> turning <input type="checkbox"/> reversing..... <input type="checkbox"/> <input type="checkbox"/> heel <input type="checkbox"/> sit..... <input type="checkbox"/> <input type="checkbox"/> Touches handler..... <input type="checkbox"/> <input type="checkbox"/> Sits between feet... <input type="checkbox"/> <input type="checkbox"/> Poor sits..... <input type="checkbox"/> <input type="checkbox"/> Poor finish..... <input type="checkbox"/>	<b>40</b>		
<b>Retrieve over high jump</b>	Fails to go out on first command or signal..... <input type="checkbox"/>  Fails to jump either direction..... <input type="checkbox"/> Fails to retrieve... <input type="checkbox"/>	Goes before command or signal..... <input type="checkbox"/> Jumps only one direction..... <input type="checkbox"/> Sits out of reach.. <input type="checkbox"/> Extra command or signal..... <input type="checkbox"/>	<input type="checkbox"/> Slow <input type="checkbox"/> Mouthing or playing..... <input type="checkbox"/> <input type="checkbox"/> Drops dumbbell <input type="checkbox"/> Poor delivery <input type="checkbox"/> Climbs jump <input type="checkbox"/> No sit in front <input type="checkbox"/> No finish <input type="checkbox"/> Handler error	<input type="checkbox"/> Going <input type="checkbox"/> Returning..... <input type="checkbox"/> <input type="checkbox"/> Touches handler... <input type="checkbox"/> <input type="checkbox"/> Sits between feet... <input type="checkbox"/> <input type="checkbox"/> Poor sit..... <input type="checkbox"/> <input type="checkbox"/> Poor finish..... <input type="checkbox"/>	<b>40</b>		
<b>Directed retrieve</b>	Does not: Go out on first command..... <input type="checkbox"/> Go directly to glove..... <input type="checkbox"/> Retrieve right article..... <input type="checkbox"/>  Fails to retrieve.. <input type="checkbox"/>	Anticipates command/signal.. <input type="checkbox"/>  Needs extra command/signal.. <input type="checkbox"/> Sits out of reach.. <input type="checkbox"/>	<input type="checkbox"/> Touches dog when sending..... <input type="checkbox"/> <input type="checkbox"/> Mouthing or playing..... <input type="checkbox"/> <input type="checkbox"/> Excessive signals..... <input type="checkbox"/> <input type="checkbox"/> Responds slowly to commands..... <input type="checkbox"/> <input type="checkbox"/> Dropping article <input type="checkbox"/> Poor delivery <input type="checkbox"/> No sit in front <input type="checkbox"/> No finish <input type="checkbox"/> Lacks naturalness/smoothness..... <input type="checkbox"/> <input type="checkbox"/> Handler error	<input type="checkbox"/> Touches handler... <input type="checkbox"/> <input type="checkbox"/> Sits between feet... <input type="checkbox"/> <input type="checkbox"/> Poor sit..... <input type="checkbox"/> <input type="checkbox"/> Poor finish..... <input type="checkbox"/>	<b>40</b>		
<b>Directed jump (High jump only)</b>	Does not: <input type="checkbox"/> Leave on order..... <input type="checkbox"/> <input type="checkbox"/> Go substantially in right direction... <input type="checkbox"/> <input type="checkbox"/> Stop on command..... <input type="checkbox"/> <input type="checkbox"/> Jump as directed..... <input type="checkbox"/> <input type="checkbox"/> Go at least 10' beyond jump..... <input type="checkbox"/>  <input type="checkbox"/> Climbs jump..... <input type="checkbox"/>  <input type="checkbox"/> Anticipates command..... <input type="checkbox"/>	<input type="checkbox"/> Holding signals..... <input type="checkbox"/> <input type="checkbox"/> Responds slowly to directions..... <input type="checkbox"/> <input type="checkbox"/> Slightly off direction..... <input type="checkbox"/> <input type="checkbox"/> Not back far enough..... <input type="checkbox"/> <input type="checkbox"/> Anticipates <input type="checkbox"/> Turn <input type="checkbox"/> Stop <input type="checkbox"/> Sit <input type="checkbox"/> Does not sit on command..... <input type="checkbox"/> <input type="checkbox"/> No sit in front/finish <input type="checkbox"/> Lacks naturalness <input type="checkbox"/> Lacks smoothness <input type="checkbox"/> Handler error	<input type="checkbox"/> Touches handler... <input type="checkbox"/> <input type="checkbox"/> Sits between feet... <input type="checkbox"/> <input type="checkbox"/> Poor sits..... <input type="checkbox"/> <input type="checkbox"/> Poor finish..... <input type="checkbox"/>	<b>40</b>			
<b>Maximum Sub-Total</b>					<b>160</b>		
<b>Moving stand</b>	Sits/lies before handler returns.... <input type="checkbox"/> Substantial move.. <input type="checkbox"/> Growls or snaps... <input type="checkbox"/> Goes to another dog..... <input type="checkbox"/>	Minor move away..... <input type="checkbox"/> Repeatedly whines or barks..... <input type="checkbox"/> Shows shyness.... <input type="checkbox"/> Shows resentment..... <input type="checkbox"/>	<input type="checkbox"/> Resists handler posing..... <input type="checkbox"/> <input type="checkbox"/> Moves feet slightly..... <input type="checkbox"/> <input type="checkbox"/> Minor whine or bark..... <input type="checkbox"/> <input type="checkbox"/> Sits/lays after handler returns..... <input type="checkbox"/> <input type="checkbox"/> Handler error..... <input type="checkbox"/>	<b>40</b>			
<b>Maximum Points</b>					<b>200</b>		
<input type="checkbox"/> Disciplining <input type="checkbox"/> Disqualified <input type="checkbox"/> Shows fear <input type="checkbox"/> Expelled <input type="checkbox"/> Fouls ring <input type="checkbox"/> Excused					<b>Less penalty for unusual behavior</b>		
Explanation of penalty					<b>TOTALNETSCORE</b>		



Utility Class

# OBEDIENCE JUDGE'S WORKSHEET

Wisconsin For Judge's Use ONLY - Not to be distributed

Pub. No. 4H439

Date: \_\_\_\_\_ Article No.: \_\_\_\_\_ Dog No.: \_\_\_\_\_

Show: \_\_\_\_\_ Breed: \_\_\_\_\_ Height (at withers): \_\_\_\_\_

Jumps: \_\_\_\_\_ Judge: \_\_\_\_\_

Exercise	Non Qualifying		Qualifying		Max points	Points off	Net score
	Zero	Less than 50%	Substantial	Minor			
<b>Signal exercise</b>	Handler adapts to dog's pace..... <input type="checkbox"/> Unmanageable..... <input type="checkbox"/> Unqualified heeling..... <input type="checkbox"/> Any audible commands..... <input type="checkbox"/>	Failure on first signal to: Stand..... <input type="checkbox"/> Stay..... <input type="checkbox"/> Drop..... <input type="checkbox"/> Sit..... <input type="checkbox"/> Come..... <input type="checkbox"/> Anticipates..... <input type="checkbox"/> Sits out of reach.. <input type="checkbox"/>	<input type="checkbox"/> Forges Crowds handler..... <input type="checkbox"/> <input type="checkbox"/> Lags Sniffs..... <input type="checkbox"/> <input type="checkbox"/> No change of pace <input type="checkbox"/> fast <input type="checkbox"/> slow..... <input type="checkbox"/> <input type="checkbox"/> Heels wide <input type="checkbox"/> turning <input type="checkbox"/> reversing..... <input type="checkbox"/> <input type="checkbox"/> Needs extra signal to: <input type="checkbox"/> heel <input type="checkbox"/> sit..... <input type="checkbox"/> <input type="checkbox"/> Holds signals..... <input type="checkbox"/> <input type="checkbox"/> Responds slowly to: <input type="checkbox"/> Stand..... Down..... Sit..... Come..... <input type="checkbox"/> <input type="checkbox"/> No sit front/finish Touches handler... <input type="checkbox"/> <input type="checkbox"/> Lacks naturalness/smoothness Sits between feet... <input type="checkbox"/> <input type="checkbox"/> Handler error Poor sits..... <input type="checkbox"/> <input type="checkbox"/> Poor finish..... <input type="checkbox"/>		<b>40</b>		
<b>Scent discrimination</b>	<b>Leather:</b> Fails 1st command..... <input type="checkbox"/> No retrieve..... <input type="checkbox"/> Wrong article..... <input type="checkbox"/> <b>Metal:</b> Fails 1st command..... <input type="checkbox"/> No retrieve..... <input type="checkbox"/> Wrong article..... <input type="checkbox"/>	<b>Leather:</b> Anticipates..... <input type="checkbox"/> Extra command.. <input type="checkbox"/> Sits out of reach.. <input type="checkbox"/> <b>Metal:</b> Anticipates..... <input type="checkbox"/> Extra command.. <input type="checkbox"/> Sits out of reach.. <input type="checkbox"/>	<b>L M</b> <input type="checkbox"/> <input type="checkbox"/> Handler roughness..... <input type="checkbox"/> <input type="checkbox"/> <input type="checkbox"/> <input type="checkbox"/> Sits after turn..... <input type="checkbox"/> <input type="checkbox"/> <input type="checkbox"/> <input type="checkbox"/> Doesn't work continuously..... <input type="checkbox"/> <input type="checkbox"/> <input type="checkbox"/> <input type="checkbox"/> Drops article on return..... <input type="checkbox"/> <input type="checkbox"/> <input type="checkbox"/> <input type="checkbox"/> Picks up/drops wrong article..... <input type="checkbox"/> <input type="checkbox"/> <input type="checkbox"/> <input type="checkbox"/> Responds slowly Mouthing..... <input type="checkbox"/> <input type="checkbox"/> <input type="checkbox"/> <input type="checkbox"/> No sit in front Touches handler... <input type="checkbox"/> <input type="checkbox"/> <input type="checkbox"/> <input type="checkbox"/> No finish Poor sit..... <input type="checkbox"/> <input type="checkbox"/> <input type="checkbox"/> <input type="checkbox"/> Handler error Poor finish..... <input type="checkbox"/> <input type="checkbox"/>		<b>L 30</b> <b>M 30</b>		
<b>Directed retrieve</b>	Does not: Go out on first command..... <input type="checkbox"/> Go directly to glove..... <input type="checkbox"/> Retrieve right article..... <input type="checkbox"/> Fails to retrieve.. <input type="checkbox"/>	Anticipates command/signal.. <input type="checkbox"/> Needs extra command/signal.. <input type="checkbox"/> Sits out of reach.. <input type="checkbox"/>	<input type="checkbox"/> Touches dog when sending..... <input type="checkbox"/> <input type="checkbox"/> Mouthing or playing..... <input type="checkbox"/> <input type="checkbox"/> Excessive signals..... <input type="checkbox"/> <input type="checkbox"/> Responds slowly to commands..... <input type="checkbox"/> <input type="checkbox"/> Drops article Touches handler... <input type="checkbox"/> <input type="checkbox"/> Poor delivery Sits between feet... <input type="checkbox"/> <input type="checkbox"/> No sit in front Poor sit..... <input type="checkbox"/> <input type="checkbox"/> No finish Poor finish..... <input type="checkbox"/> <input type="checkbox"/> Lacks naturalness/smoothness..... <input type="checkbox"/> <input type="checkbox"/> Handler error		<b>40</b>		
<b>Directed jump (High jump and Bar jump)</b>	<b>H B</b> Does not: <input type="checkbox"/> <input type="checkbox"/> Leave on order..... <input type="checkbox"/> <input type="checkbox"/> <input type="checkbox"/> <input type="checkbox"/> Go mainly in right direction.. <input type="checkbox"/> <input type="checkbox"/> <input type="checkbox"/> <input type="checkbox"/> Stop on command..... <input type="checkbox"/> <input type="checkbox"/> <input type="checkbox"/> <input type="checkbox"/> Jump as directed..... <input type="checkbox"/> <input type="checkbox"/> <input type="checkbox"/> <input type="checkbox"/> Go at least 10' beyond jump.. <input type="checkbox"/> <input type="checkbox"/> <input type="checkbox"/> Climbs jump..... <input type="checkbox"/> <input type="checkbox"/> Knocks bar off..... <input type="checkbox"/> <input type="checkbox"/> <input type="checkbox"/> Anticipates command..... <input type="checkbox"/> <input type="checkbox"/>	<b>H B</b> <input type="checkbox"/> <input type="checkbox"/>	<input type="checkbox"/> Holds signals..... <input type="checkbox"/> <input type="checkbox"/> Responds slowly to directions..... <input type="checkbox"/> <input type="checkbox"/> Slightly off direction..... <input type="checkbox"/> <input type="checkbox"/> Not back far enough..... <input type="checkbox"/> <input type="checkbox"/> Anticipates <input type="checkbox"/> Turn <input type="checkbox"/> Stop <input type="checkbox"/> Sit <input type="checkbox"/> Does not sit on command..... <input type="checkbox"/> <input type="checkbox"/> No sit in front/finish Touches handler... <input type="checkbox"/> <input type="checkbox"/> Lacks naturalness Sits between feet... <input type="checkbox"/> <input type="checkbox"/> Lacks smoothness Poor sits..... <input type="checkbox"/> <input type="checkbox"/> Handler error Poor finish..... <input type="checkbox"/>		<b>40</b>		
<b>Maximum Sub-Total</b>					<b>180</b>		
<b>Moving stand</b>	Sits/lies before handler returns... <input type="checkbox"/> Substantial move.. <input type="checkbox"/> Grows or snaps... <input type="checkbox"/> Goes to another dog..... <input type="checkbox"/>	Minor move away..... <input type="checkbox"/> Repeatedly whines or barks..... <input type="checkbox"/> Shows shyness... <input type="checkbox"/> Shows resentment..... <input type="checkbox"/>	<input type="checkbox"/> Resists handler posing..... <input type="checkbox"/> <input type="checkbox"/> Moves feet slightly..... <input type="checkbox"/> <input type="checkbox"/> Minor whine or bark..... <input type="checkbox"/> <input type="checkbox"/> Sits/lays after handler returns..... <input type="checkbox"/> <input type="checkbox"/> Handler error..... <input type="checkbox"/>		<b>20</b>		
<b>Maximum Points</b>					<b>200</b>		
<input type="checkbox"/> Disciplining <input type="checkbox"/> Shows fear <input type="checkbox"/> Fouls ring <input type="checkbox"/> Disqualified <input type="checkbox"/> Expelled <input type="checkbox"/> Excused					<b>Less penalty for unusual behavior</b>		
Explanation of penalty					<b>TOTALNET SCORE</b>		

---

## <sup>UW</sup>**Extension**

“An EEO/AA employer, University of Wisconsin-Extension provides equal opportunities in employment and programming, including Title IX and American with Disabilities (ADA) requirements.”

© 2004 by the Board of Regents of the University of Wisconsin System. Developed by the Wisconsin 4-H Office, 431 Lowell Hall, 610 Langdon St., Madison, WI 53703. The 4-H name and emblem are federally protected under Title 18 US Code 707.

Created by Melanie Miller, Marilyn and Gerald Hrabik, Michelle Zimmerman, Deanna Schneider, and Wayne Brabender. Layout and design revised by Gretchen Krause, 4-H Youth Development Graphic Artist, February 2004.

To order multiple copies of this publication, call toll free: 1-877-WIS-PUBS (947-7827). To see more Cooperative Extension Information, visit our web site: <http://cecommerce.uwex.edu>.

